

CWMA Specifications and Tolerances (S&T) Committee 2021 Annual Meeting Report

Mr. Charles Stutesman, Committee Chair
Kansas

INTRODUCTION

The S&T Committee will address the following items in Table A during the Interim Meeting. Table A identifies the agenda items by reference key, title of item, page number and the appendices by appendix designations. The headings and subjects apply to *Handbook 44 Specifications, Tolerances, and Other Technical Requirements for Weighing and Measuring Devices, 2020 Edition*. The first three letters of an item's reference key are assigned from the Subject Series List. The next 2 digits represent the year the item was introduced. The acronyms for organizations and technical terms used throughout the agenda are identified in Table B. In some cases, background information will be provided for an item. The fact that an item appears on the agenda does not mean it will be presented to the National Conference on Weights and Measures (NCWM) for a vote. The Committee will review its agenda and may withdraw some items, present some items for information meant for additional study, issue interpretations, or make specific recommendations for change to the publications identified, which will be presented for a vote at the Annual Meeting. The Committee may also take up routine or miscellaneous items brought to its attention after the preparation of this document. The Committee may decide to accept items for discussion that are not listed in this document, providing they meet the criteria for exceptions as presented in NCWM Policy 3.1.4. Handbooks, *Procedures to Modify Handbooks*. The Committee has not determined whether the items presented will be Voting or Informational in nature; these determinations will result from their deliberations at the Interim Meeting.

An "Item under Consideration" is a statement of proposal and not necessarily a recommendation of the Committee. Suggested revisions are shown in **bold face print** by ~~striking out~~ information to be deleted and underlining information to be added. Requirements that are proposed to be nonretroactive are printed in *bold faced italics*.

In some cases, there may be proposed changes affecting multiple model laws or regulations that share the same purpose or proposed changes to one model law or regulation may be dependent on the adoption of proposed changes to another. The Committee may group such items into "Blocks" to facilitate efficient handling for open hearings and voting. These blocks are identified in Committee's agenda.

All sessions are open to registered attendees of the conference. If the Committee must discuss any issue that involves proprietary information or other confidential material; that portion of the session dealing with the special issue may be closed if (1) the Chairman or, in his absence, the Chairman-Elect approves; (2) the Executive Director is notified; and (3) an announcement of the closed meeting is posted on or near the door to the meeting session and at the registration desk. If possible, the posting will be done at least a day prior to the planned closed session.

Note: It is policy to use metric units of measurement in publications; however, recommendations received by NCWM technical committees and regional weights and measures associations have been printed in this publication as submitted. Therefore, the report may contain references to inch-pound units.

Subject Series List

| | |
|---|------------|
| NIST Handbook 44 – General Code | GEN Series |
| Scales | SCL Series |
| Belt-Conveyor Scale Systems | BCS Series |
| Automatic Bulk Weighing Systems | ABW Series |
| Weights | WTS Series |
| Automatic Weighing Systems | AWS Series |
| Weigh-In-Motion Systems used for Vehicle Enforcement Screening | WIM Series |
| Liquid-Measuring Devices | LMD Series |
| Vehicle-Tank Meters | VTM Series |
| Liquefied Petroleum Gas and Anhydrous Ammonia Liquid-Measuring Devices | LPG Series |
| Hydrocarbon Gas Vapor-Measuring Devices | HGV Series |
| Cryogenic Liquid-Measuring Devices | CLM Series |
| Milk Meters | MLK Series |
| Water Meters | WTR Series |
| Mass Flow Meters | MFM Series |
| Carbon Dioxide Liquid-Measuring Devices | CDL Series |
| Hydrogen Gas-Metering Devices | HGM Series |
| Electric Vehicle Refueling Systems | EVF Series |
| Vehicle Tanks Used as Measures | VTU Series |
| Liquid Measures | LQM Series |
| Farm Milk Tanks | FMT Series |
| Measure-Containers | MRC Series |
| Graduates | GDT Series |
| Dry Measures | DRY Series |
| Berry Baskets and Boxes | BBB Series |
| Fabric-Measuring Devices | FAB Series |
| Wire-and Cordage-Measuring Devices | WAC Series |
| Linear Measures | LIN Series |
| Odometers | ODO Series |
| Taximeters | TXI Series |
| Timing Devices | TIM Series |
| Grain Moisture Meters (a) | GMA Series |
| Grain Moisture Meters (b) | GMB Series |
| Near-Infrared Grain Analyzers | NIR Series |
| Multiple Dimension Measuring Devices | MDM Series |
| Electronic Livestock, Meat, and Poultry Evaluation Systems and/or Devices | LVS Series |
| Transportation Network Measuring Systems | TNS Series |
| Other Items | OTH Series |

Table A
Table of Contents

| Reference Key | Title of Item | S&T Page |
|--|---|---------------------|
| GEN – GENERAL CODE6 | | |
| GEN-20.1 | W G-T.3. Application and Appendix D – Definitions: true value | 6 |
| GEN-21.1 | W Use-for-Fee Vehicle and Axle-Load Scales | 7 |
| BLOCK 2 ITEMS (B2) DEFINE TRUE VALUE FOR USE IN ERROR CALCULATIONS12 | | |
| B2: SCL-20.3 | A S.5.4. Relationship of Minimum Load Cell Verification Interval to the Scale Division | 12 |
| B2: SCL-20.4 | A Table 3. Parameters of Accuracy Classes. | 13 |
| B2: SCL-20.5 | A Table S.6.3.a. Marking Requirements, Note 3. | 15 |
| B2: SCL-20.6 | A T.N.1.2. Accuracy Classes and T.N.1.3. Scale Division. | 15 |
| B2: SCL-20.7 | A Table 7. Maintenance Tolerances..... | 15 |
| B2: SCL-20.8 | A Table 8. Recommended Minimum Load..... | 15 |
| SCL – SCALES25 | | |
| SCL-16.1 | W Sections Throughout the Code to Include Provisions for Commercial Weigh-in-Motion Vehicle Scale Systems..... | 25 |
| SCL-17.1 | V S.1.8.5. Recorded Representations, Point of Sale Systems | 33 |
| SCL-21.1 | W S.1.1. Zero Indication..... | 39 |
| SCL-20.9 | D S.1.1.3. Zero Indication, Load Receiving Elements Separate from Weighing Elements. and Appendix D – Definitions: no load reference value | 43 |
| SCL-20.12 | V Sections Throughout the Code to Include Provisions for Commercial Single Draft Weigh-in-Motion Vehicle Scales..... | 45 |
| ABW – AUTOMATIC BULK WEIGHING SYSTEMS54 | | |
| ABW-16.1 | W A. Application, S Specifications, N. Notes, UR. User Requirements and Appendix D – Definitions: automatic bulk weighing system..... | 54 |
| BLOCK 4 ITEMS (B4) ELECTRONICALLY CAPTURED TICKETS OR RECEIPTS.....60 | | |
| B4: GEN-21.2 | D G-S.5.6. Recorded Representations..... | 60 |
| B4: LMD-21.2 | D S.1.6.5. Money Value Computations., UR.3. Use of a Device. | 61 |
| B4: VTM-21.1 | D S.1.1. Primary Elements., UR.2. User Requirements..... | 63 |
| B4: LPG-21.1 | D S.1.1. Primary Elements., UR.2. User Requirements..... | 64 |
| B4: CLM-21.1 | D S.1.4.1. Printed Ticket Recorded Representation., UR.2.6.3. Printed Ticket Recorded Representation. | 66 |
| B4: MLK-XX.XD | S.1.4.2. Printed Ticket Recorded Representation., UR.2.6.3. Printed Ticket Recorded Representation. | 66 |
| B4: MFM-21.2 | D S.6. Printer Recorded Representations., UR.2.6. Ticket Printer, Customer Ticket, Recorded Representation., UR.3.4. Printed Ticket Recorded Representation. | 66 |
| B4: CDL-21.1 | D S.1.4.1. Printed Ticket Recorded Representations., UR.2.4.2. Tickets or Invoices. Recorded Representation. | 67 |
| B4: HGM-21.1 | D S.2.6. Recorded Representations, Point of Sale Systems., S.6. Printer. Recording Element., UR.3.2. Vehicle-mounted Measuring Systems Ticket Printer Recording Element., UR.3.3. Printed Ticket. Recorded Representation. | 68 |
| B4: OTH-21.2 | D Appendix D - Definitions.: recorded representations, recording element. | 69 |
| BLOCK 1 ITEMS (B1) TERMINOLOGY FOR TESTING STANDARDS (VERIFICATION STANDARDS, FIELD STANDARDS, TRANSFER STANDARDS, FIELD REFERENCE STANDARDS, ETC.,) TOLERANCES ON TESTS WHEN TRANSFER STANDARDS ARE USED, MINIMUM QUANTITY FOR FIELD REFERENCE STANDARD METER TESTS.....79 | | |
| B1: GEN-19.1 | A G-T.5. Tolerances on Tests When Transfer Standards are Used., Appendix D – Definitions: standards, field., transfer standard. and standard, transfer. | 79 |
| B1: SCL-18.1 | A N.2. Verification (Testing) Standards | 81 |
| B1: ABW-18.1 | A N.2. Verification (Testing) Standards | 81 |

| | | |
|--|--|------------|
| B1: AWS-18.1 | A N.1.3. Verification (Testing) Standards, N.3.1. Official Tests, UR.4. Testing Standards | 81 |
| B1: CLM-18.1 | A N.3.2. Transfer Standard Test and T.3. On Tests Using Transfer Standards | 82 |
| B1: CDL-18.1 | A N.3.2. Transfer Standard Test, T.3. On Tests Using Transfer Standards | 82 |
| B1: HGM-18.1 | A N.4.1. Master Meter (Transfer) Standard Test, T.4. Tolerance Application on Test Using Transfer Standard Test Method | 82 |
| B1: GMM-18.1 | A 5.56(a): N.1.1. Air Oven Reference Method Transfer Standards, N.1.3. Meter to Like-Type Meter Method Transfer Standards and 5.56(b): N.1.1. Transfer Standards, T. Tolerances ¹ | 82 |
| B1: LVS-18.1 | A N.2. Testing Standards | 83 |
| B1: OTH-18.1 | A Appendix A: Fundamental Considerations, 3.2. Tolerances for Standards, 3.3. Accuracy of Standards | 83 |
| B1: OTH-18.2 | A Appendix D – Definitions: fifth-wheel, official grain samples, transfer standard and Standard, Field | 84 |
| B1: CLM-18.2 | A N.3.2. Transfer Standard Test and T.3. On Tests Using Transfer Standards | 84 |
| B1: CDL-18.2 | A N.3.2. Transfer Standard Test and T.3. On Tests Using Transfer Standards | 85 |
| B1: HGM-18.2 | A N.4.1. Master Meter (Transfer) Standard Test and T.4. Tolerance Application on Test Using Transfer Standard Test Method | 85 |
| B1: OTH-18.3 | A Appendix D – Definitions: field reference standard meter and transfer standard | 85 |
| B1: LPG-15.1 | A N.3. Test Drafts | 86 |
| B1: MFM-15.1 | A N.3. Test Drafts | 86 |
| BLOCK 5 ITEMS (B5) CATEGORY 3 METHODS OF SEALING | | 89 |
| B5: LMD-20.1 | W Table S.2.2. Categories of Device and Methods of Sealing | 89 |
| B5: LMD-21.1 | D Table S.2.2. Categories of Device and Method of Sealing | 91 |
| VTM – VEHICLE TANK METERS | | 94 |
| VTM-18.1 | D S.3.1 Diversion of Measured Liquid and S.3.1.1. Means for Clearing the Discharge Hose and UR.2.6. Clearing the Discharge on a multiple-product, single discharge hose | 94 |
| VTM-20.1 | W S.3.1. Diversion of Measured Liquid | 99 |
| VTM-20.2 | V Table T.2. Tolerances for Vehicle Mounted Milk Meters | 99 |
| MFM – MASS FLOW METERS | | 105 |
| MFM-21.1 | W UR.3.3. Ticket Printer: Customer Ticket | 105 |
| EVF – ELECTRIC VEHICLE FUELING SYSTEMS | | 107 |
| EVF-21.1 | W A.1. General | 107 |
| EVF-21.2 | W A.2. Exceptions | 110 |
| EVF-20.1 | D S.1.3.2. EVSE Value of the Smallest Unit | 113 |
| EVF-20.2 | V Definitions: Submeter | 115 |
| EVF-21.3 | W S.1.2. EVSE Indicating Elements, S.2.4.1. Unit Price, S.2.5. EVSE Money-Value Computations., S.2.7. Indication of Delivery | 118 |
| EVF-21.4 | V S.3.3. Provision for Sealing | 122 |
| EVF-21.5 | W T.2. Load Test Tolerances | 125 |
| EVF-21.6 | V Definitions: minimum measured quantity (MMQ) | 129 |
| TXI – TAXIMETERS | | 131 |
| See Block 3 Items: Tolerances for Distance Testing | | 131 |
| GMA – GRAIN MOISTURE METERS 5.56 (A) | | 131 |
| GMA-19.1 | D Table T.2.1. Acceptance and Maintenance Tolerances Air Oven Method for All Grains and Oil Seeds | 131 |
| BLOCK 3 ITEMS (B3) TOLERANCES FOR DISTANCE TESTING IN TAXIMETERS AND TRANSPORTATION NETWORK SYSTEMS | | 134 |
| B3: TXI-20.1 | w T. Tolerances | 134 |
| B3: TNS-20.1 | W T. Tolerances | 134 |
| OTH – OTHER ITEMS | | 137 |
| OTH-16.1 | D Electric Watthour Meters Code under Development | 137 |
| OTH-21.1 | V Appendix A – 2.1. Acceptance and Maintenance Tolerances | 140 |

Appendices

A Item SCL-20.12 – Summary of Revisions Following the 2020 Interim MeetingA143
 B Item Block 2 – Final Report of the Verification Scale Division Task Group B153

Table B
Glossary of Acronyms and Terms

| Acronym | Term | Acronym | Term |
|----------------|---|----------------|--|
| ABWS | Automatic Bulk Weighing System | NEWMA | Northeastern Weights and Measures Association |
| AAR | Association of American Railroads | NIST | National Institute of Standards and Technology |
| API | American Petroleum Institute | NTEP | National Type Evaluation Program |
| CNG | Compressed Natural Gas | OIML | International Organization of Legal Metrology |
| CWMA | Central Weights and Measures Association | OWM | Office of Weights and Measures |
| EPO | Examination Procedure Outline | RMFD | Retail Motor Fuel Dispenser |
| FHWA | Federal Highway Administration | S&T | Specifications and Tolerances |
| GMM | Grain Moisture Meter | SD | Secure Digital |
| GPS | Global Positioning System | SI | International System of Units |
| HB | Handbook | SMA | Scale Manufacturers Association |
| LMD | Liquid Measuring Devices | SWMA | Southern Weights and Measures Association |
| LNG | Liquefied Natural Gas | TC | Technical Committee |
| LPG | Liquefied Petroleum Gas | USNWG | U.S. National Work Group |
| MMA | Meter Manufacturers Association | VTM | Vehicle Tank Meter |
| MDMD | Multiple Dimension Measuring Device | WIM | Weigh-in-Motion |
| NCWM | National Conference on Weights and Measures | WWMA | Western Weights and Measures Association |

Details of All Items
(In order by Reference Key)

GEN – GENERAL CODE

GEN-20.1 W G-T.3. Application and Appendix D – Definitions: true value

NOTES:

1. *At the 2020 NCWM Interim Meeting the Committee agreed to remove this item from Block 2 and make it a separate item. See background information under Block 2 of this report for additional details.*
2. *While this item was carried over from the 2020 Interim Meeting, it was not a voting item and therefore not discussed during the continuation of the 2020 Annual Meeting. Instead, it was placed on the 2021 Interim Meeting's agenda and was considered during that meeting.*

Item Under Consideration:

Amend Handbook 44, General Code as follows:

G-T.3. Application. ~~Tolerances “in excess” and tolerances “in deficiency” shall apply to errors in excess and to errors in deficiency, respectively. Tolerances “on overregistration” and tolerances “on underregistration” shall apply to errors in the direction of overregistration and of underregistration, respectively. Measurement errors shall be in reference to the “true value,” which shall be the legal basis of all tolerance compliance. The calculation of measurement error in testing shall follow these principles:~~

- (a) When tolerances in a code are expressed as tolerances “in excess” and tolerances “in deficiency,” error shall be calculated as: Error = True Value – Device Indication. Plus (+) errors are “in excess” and minus (-) errors are “in deficiency”. These errors may also be known as “errors of delivery.”**
- (b) When tolerances in a code are expressed as tolerances “on overregistration” and tolerances “on underregistration,” error shall be calculated as: Error = Device Indication – True Value.” Plus (+) errors are “on overregistration” and minus (-) errors are “on underregistration.” These errors may also be known as “errors of indication.”**
- (c) The percent error in all cases shall be calculated as: Error% = Error / True Value * 100
Example: if the error is +1 g and the true value is 100 g, the error% is +1 %**

(Also see Appendix D, Definitions.)
(Amended 20XX)

And amend Appendix D – Definitions as follows:

True Value. – A value representing the quantity of a reference used in evaluating tolerance compliance, which is obtained using prescribed, traceable standards and a prescribed test procedure performed by an authorized person. The true value is expressed without uncertainty and is considered to have no error. The true value may be assigned prior to conducting the test or during the conduct of the test. Examples: When testing a scale using a test weight, the true value of the test weight is typically assigned by an authorized laboratory prior to conducting the test. When testing a liquid measuring device, the true value of the test draft is assigned by the authorized inspector during the conduct of the test.

(Added 20XX)

Background/Discussion:

2020 NCWM Interim Meeting: The Committee agreed to remove this item from Block 2 and make it a separate item. The Committee acknowledged the receipt of comments from some of the regional associations concerning the use of the term “True Value” in the formulas included in subparts (a) & (b) and how that term is defined in the proposal. The Committee agreed that there may be value in further defining the application of tolerance and that the item should be given a Developing status adding that consideration should be given to amending the use of the term “True Value.”

2020 NCWM Annual Meeting: Due to the 2020 Covid-19 pandemic, this meeting was adjourned to January 2021, at which time it was held as a virtual meeting. Due to constraint of time, only those items designated as 2020 Voting Items were addressed. All other items were addressed in the subsequent 2021 NCWM Interim Meeting.

2021 NCWM Interim Meeting: The Committee heard comments questioning the need for the changes being proposed in this item. Also heard was a comment suggesting a possible benefit to use the formulae provided in this proposal for anyone that is confused by the terms overregistration and underregistration. Other comments pointed out error in the use of a “plus” sign in subparts (a) and (b) in the proposal and some that believe the identification of “tolerances in deficiency” and “tolerances in excess” in this proposal is incorrect.

During the committee’s work session at the 2021 Interim Meeting the Committee concluded that the item should be Withdrawn however, there may be some value to the formulae included in this proposal and it is recommended that the submitter may consider drafting another proposal to include these formulae in the HB 44 Fundamental Considerations and then to submit that proposal later.

Regional Association Comments:

2020 Regional Meetings of the WWMA, NEWMA, and SWMA: These regions adhered to a condensed agenda due to the Covid pandemic and did not consider this item.

CWMA 2020 Interim Meeting: The CWMA S&T Committee heard from numerous regulatory officials questioning that if the purpose of this item is to provide clarity, it seems to provide more confusion. We feel this item is not a necessary addition to the handbook, and recommend this item be withdrawn.

Additional letters, presentations and data may have been part of the Committee’s consideration. Please refer to <https://www.ncwm.com/publication-16> to review these documents.

| CWMA Report |
|--|
| Comments and justification for the regional recommendation to NCWM: <i>(This will appear in NCWM reports)</i> |
| No comments on withdrawn items. |

GEN-21.1 W Use-for-Fee Vehicle and Axle-Load Scales

Source:

NIST Office of Weights and Measures

Purpose:

Solicit input to help develop a future proposal to amend Handbook 44 to address devices such as vehicles scales that provide axle weights for a fee.

Item Under Consideration:

To be developed for either the General Code, Scales Code, or both.

Previous Action:

- N/A

Original Justification:

The purpose of creating this new developing item is to solicit Input from the weights and measures enforcement community and affected stakeholders to help develop a future proposal to amend NIST Handbook 44 to address the following concern:

Handbook 44 does not provide sufficient detail to address the predominant use of permanently installed axle-load scales, multi-platform vehicle scale systems, and, perhaps to a lesser extent, single-platform vehicle scales in the weighing of axle- and axle-group loads of vehicles for a fee. This leaves open the question of whether or not NIST Handbook 44 was intended to apply to scales used for this purpose (although we think most would agree that it should) and if so, to what extent are requirements intended to apply.

States are inconsistent in their inspection of these devices and systems, especially with respect to their use in determining total vehicle weight from the summation of the different axle- and axle-group loads. Such application of these scales satisfies an important need. Truck drivers and many of the companies that employ them, rely on their accuracy to determine whether loads to be transported have been distributed properly over the different axles and axle groups of the truck to know whether the vehicle complies with federal and state legal load limits in effect. The intended purpose of state and federal loading limits is to ensure the safe transport of loads over roadways and minimize pavement damage.

Modifications may be necessary to General Code Paragraph G-A.1. Application. Modifications and/or additions may also be necessary to the Scales Code, including modifications to paragraphs such as UR.3.3. Single-Draft Vehicle Weighing and possibly other sections to clarify the appropriate use of these devices about the need to make weighments in a single draft.

Providing it's agreed that the use of permanently installed axle-load scales, multi-platform vehicle scale systems, and single-platform vehicle scales in providing axle, axle-group loads and total vehicle weight of vehicles weighed for a fee constitutes "commercial" use of these scales then we believe, as an initial step, the Application section of the Scales Code (and/or perhaps the General Code) needs to be amended to make clear the application of HB 44 to these scales.

The following are some issues/concerns that will need to be addressed through possible future changes to NIST HB 44:

- Scales Code UR.3.3 Single-Draft Weighing requires a vehicle or coupled vehicle combination to be "commercially weighed" on a vehicle scale only as a single-draft, although subpart (b) of this paragraph allows the weight of a vehicle or coupled vehicle combination to be determined by adding together the weights obtained while all axle and axle groups of a vehicle are resting simultaneously on more than one scale platform. Some have questioned whether the practice of assessing a fee for the service of providing a weight is considered commercial. Others believe this practice is already addressed by the General Code paragraph G-A.1. Application in the reference made in that paragraph to a commercial device being one that is used for hire in determining quantities (such as weights).

Thus, the intended meaning of "commercially weighed" in Scales Code paragraph UR.3.3. is not clear. The note that's part of this paragraph provides an exception for highway enforcement scales and scales used for the collection of statistical data. The exception does not extend to vehicle scales used to determine axle- and axle-group loads and/or total vehicle weight for a fee. This paragraph would need to be amended to make clear the permissible use of permanently installed vehicle scales to weigh individual axles and axle groups (not for use in commercial transactions) for a fee when not all axles and axle groups of a truck are resting simultaneously on more than one platform. It might also be amended to make clear the permissible use of permanently installed axle-load scales to perform this same function.

- Is it permissible for an axle-load scale or a vehicle scale to print a summed total (i.e., total vehicle weight) of the different axles and axle-groups of vehicles that are weighed in separate, multiple drafts? If so, disclosure is needed on the ticket to make evident the vehicle was not weighed as a single draft and, for this reason, the vehicle's total weight is not to be used for commercial transactions. Some weight tickets that have been provided to OWM are not clearly marked to indicate the permissible use of such weights, leading to the possibility that the weights may be inappropriately used for trade. Additional requirements such as that provided in other sections of the Scales Code which require specific markings on the weight tickets (to restrict their use or call attention to how they were derived), may be necessary to ensure appropriate use of the weights obtained from these scales. For example, this might include the addition of a requirement for a marking such as "this weight is not for commercial use"

- The approach requirements for axle-load scales and vehicle scales differ in NIST 44 differ, and for good reason. The approach requirement for axle-load scales (Scales Code paragraph UR.2.6.2.) requires a straight paved approach at each end of the scale in the same plane as the platform. The approaches (i.e., one at each end of the platform) are required to be the same width as the platform and of sufficient length to ensure the level positioning of vehicles during weight determinations. The level positioning of vehicles when being weighed is very important because previous studies have shown that if any portion of the vehicle is above or below grade of the platform when the different axles and axle groups are being weighed, the force of the load transfers to other axle and/or axle groups of the vehicle. This transfer of force results in large weighing errors for the individual axle and axle-groups. This fact becomes a very important consideration when deciding whether or not vehicle scales should be permitted to provide this same service. Only the first 10 feet of an approach to a vehicle scale is required to be in the same plane as the platform, which leads to several questions and concerns as follows:
 1. Is it an appropriate use of a vehicle scale to provide such service when the approaches of the scale do not provide for the level positioning of vehicles during weight determinations given what is known about the transfer of the force of the load between axles and axle groups when vehicles being weighed are not level and in the same plane as the scale platform?
 2. Is it an appropriate use of a vehicle scale to provide such service when the approaches of the scale do provide for the level positioning of vehicles during weight determinations? If so, under what conditions may the scale be used for this purpose? Consider the following:
 - a) Vehicle scale platforms range in length, some as short as 30 feet and some perhaps 70 feet or longer. Considering these different platform lengths and the different axle configurations of the many trucks on US roadways, what would be considered acceptable procedures for determining the individual axle and axle-group loads of those different trucks? For example, it is not possible to weigh the tandem drive axles of a 5-axle tractor trailer by itself on a vehicle scale that has a platform length shorter than the spacing between steering axle and rear axle of the tandem drive axles of the tractor. Should the tandem drive axles be weighed with the steering axle and then the weight of the steering axle subtracted from the result to yield the load on the drive axles?
 - b) Several US scale manufacturers offer a three-independent platform vehicle scale system; each independent weighing/load receiving element having its own weight display and a fourth display that provides a summed total of the three. One US scale manufacturer recently reported that the current NTEP CC for the three-platform vehicle scale system it produces is for a “vehicle scale” and nowhere on the NTEP certificate appears the term “axle-load scale.” It is not known the type of scale NTEP has designated for other such systems.

Weights and measures jurisdictions have long considered the application of these systems “commercial” and have been approving them for use in determining axle- and axle-group loads as well as total vehicle weight (i.e., total vehicle weight from the summing of the individual axle and axle-group loads when all can be weighed simultaneously on one or more platforms) for a fee. Not all vehicles to be weighed on these systems, however, can fit onto them. That is, the distance from the front axle to the furthest rear axle of some vehicles (e.g., vehicles that are oversized or have spread axles) exceeds the total combined length of the three scale platforms. When this occurs, oftentimes such vehicles are split weighed (i.e., weighed in multiple drafts without all individual elements resting simultaneously on one of the scale platforms when the weights are determined). Additionally, there exists anecdotal reporting that the approaches to some of these vehicle scale systems meet the requirements for both axle-load scales and vehicle scales, while others meet only the approach requirements for vehicle scales.

When considering the use of these systems to weigh vehicles for which all axles and axle groups are unable to fit onto the platforms and be weighed simultaneously, the following are several questions needing addressed:

- I. Is it an appropriate use of these systems to provide individual axle and axle group loads? If so, should such use be restricted to only those systems in which the entrance and exit approaches are of sufficient length to ensure the level positioning of all vehicles during weight determinations?
- II. Must the different values recorded by the system identify the position of the different axle and axle groups of a vehicle?
- III. When total vehicle weight is also provided (from the summing of the different axle and axle group loads) how must it be disclosed on the ticket given that paragraph UR.3.3. prohibits vehicles from being “commercially weighed” using such procedures.

- IV. Under what conditions could the scale system's owner/operator be able to provide axle-, axle-group loads, and total vehicle weight for a fee?

Given the complexity of this issue, it is likely that additional questions and issues will arise through discussion of this developing item.

The submitter acknowledges that Some scale manufacturers may prefer there be no additional clarifications added to NIST Handbook 44 to address the use of these scales and weighing systems. Future changes made to NIST Handbook 44 to address the many concerns/issues indicated in Section 17 of this form may necessitate the use of different procedures (than those currently used) to weigh vehicles, some of which may take longer to complete. Additionally, the discussions alone could possibly prompt jurisdictions to required changes to the weight ticket to ensure weight values are clearly identified and designated.

Given the variety of different vehicle axle/axle grouping configurations, it may not be practical to manufacture and place into service scales capable of accommodating all of the possible combinations of vehicle axles/axle groupings such that they could be weighed in a single draft. Therefore, there may be those supporting the use of vehicle scales in violation of current requirements and may try to justify the practice of "split-weighing" on vehicle scales to obtain axle/axle group weights. That support could create complexity and additional complications for enforcement of Scales Code requirement UR.3.3. "Single-Draft Vehicle Weighing."

The submitter requested Developing status for this item in 2021.

Comments in Favor:

Regulatory:

- Apply Developing status so that concerns outlined by NIST OWM can be vetted.
- Charging of fees for use of a scale should be considered a commercial transaction.

Industry:

- N/A

Advisory:

- N/A

Comments Against:

Regulatory:

- The item should be withdrawn because it lacks a proposal for consideration.
- Charging of fees for use of a scale should be considered a commercial transaction.
- General Code G-A.1. already includes the "hire" of a weighing/measuring device as a commercial device.

Industry:

- General Code G-A.1. already includes the "hire" of a weighing/measuring device as a commercial device.

Advisory:

- N/A

Neutral Comments:

Regulatory:

-

Industry:

-

Advisory:

-

Item Development:

The Committee members shared their thoughts about maintaining a placeholder on its agenda to solicit input, but they also stated their reservations about assigning a status since there is no specific proposal. The Committee agreed to withdraw the item.

Regional Association Comments:

WWMA 2020 Annual Meeting: The Committee heard comments from:

John Barton (NIST-OWM) Not all vehicles do not fit on a single draft weighment resulting in multi draft weighments. HB 44 requires a single draft weighment for commercial draft transaction. In addition, there is confusion whether an axle weight is a commercial transaction when there is a fee applied to the weighment process. NIST recommends it is a developing item. Mr. Barton further clarified the different approach requirement between axle scales and vehicle scales. Eric Golden (Cardinal Scales) Discussed weighing sector a whether it was a commercial transaction. Cardinal scale views these axle load weighments as a commercial transaction. Lou Straub (Fairbanks Scale) stated that he wanted data on how many oversized vehicles there really are being weighed. On a CAT scale printout if it is a multi-draft ticket has a statement that the weight listed are not certifiable. Steven Harrington (Oregon W&M) Axle Weight with a fee is a commercial transaction. He stated many different axel configurations are available. Oregon ODOT uses axle weight for law enforcement.

The Committee agreed to assign this item with a Developing status with recommendation that the submitter poll jurisdictions on whether these are commercial transactions.

SWMA 2020 Annual Meeting: During the Open Hearings, the Committee heard comments from John Barton (OWM) who stated that OWM would like the item to move forward as Developing. The issue originated from a field inspector who witnessed a truck trying to get a weighment from a scale that was much shorter than the truck. He stated that many issues have arisen around the Handbooks lack of clarity such as excessively long trucks, the validity of axle weight scales, the issue of single draft weighing vs split weighing, and whether paying for a weighment constitutes a commercial transaction. The committee also heard from Lou Straub (Fairbanks) who stated that he agrees with Mr. Barton, and the item should be made Developing. He stated that the Handbook does not apply to law enforcement scales, and that many of these scales are not used commercially. He stated that split weighing is not appropriate for commercial transactions, but that we need to clarify this for the big picture. The committee also heard from Eric Golden (Cardinal Scales) who agrees that this item should be made developing. He also stated that split weighing can be used if a truck is too long, but that it is not legal for trade. He questioned whether this would apply to CAT scales or just small axle load scales, and that he believed that charging for a weighment is a commercial transaction. The committee also heard from Tim Chesser (Arkansas) who stated that this was a non-issue in Arkansas. The committee also heard from Hal Prince (Florida) who stated that he would like a clarification on the definition of charging for weighments as a commercial transaction added to the handbook. The Committee also heard from Ken Ramsburg (Maryland) who stated that he agrees with the item being made developmental. He stated that paying for weighments is considered a commercial transaction in Maryland. He also stated that the issue of split weighing needs to be dealt with to protect from fraud. He stated that notice of split weighing should be required on the ticket. Lou Straub also stated that the Handbook does not currently require vehicle scales to have a ticket printer, nor does it have specific recording requirements. Tim Chesser also stated that he agreed that the Handbook was behind on Recording Requirements, and whether NIST and SMA would develop this. John Barton stated that NIST OWM would develop the issue, and Russ Vires (Scale Manufacturers Association) stated that SMA would review the issue in November and that Mettler Toledo will participate in the development of this issue.

After considering this item the Committee recommends the item be given Developing status.

NEWMA 2020 Interim Meeting: The Committee agrees with the body that this proposal has merit and recommends this be a Developing Item. The submitter (NIST) described the motivation for the item and the desired results to be achieved in development. This may require modifications/additions to the general code, scale code and possibly other sections. Differences in the requirements for vehicle scales and axle load scales were outlined. There are requirements for trucks traveling on public highways to obtain weights for compliance with highway weight limits and the length of these trucks does not always allow for single draft weighments. During open hearings, the Committee heard comments from industry and state officials defining current regulations in HB44 and current State practices. The submitter is open to further discussion and development to address issues and concerns.

CWMA 2020 Interim Meeting: The S&T Committee received comments from both regulatory officials and industry representatives discussing the numerous issues that this item has brought to light. The developer requested this item be given a developing status. We agree with the developer and recommend Developing status.

| CWMA Report |
|--|
| Comments and justification for the regional recommendation to NCWM: <i>(This will appear in NCWM reports)</i> |
| No comments on withdrawn items. |

BLOCK 2 ITEMS (B2) DEFINE TRUE VALUE FOR USE IN ERROR CALCULATIONS

NOTES:

1. *At the 2020 NCWM Interim Meeting the committee agreed that GEN-20.1, SCL-20.1 and SCL-20.2 should be removed from Block 2 and given individual consideration. The items included in this block 2 are SCL-20.3, SCL-20.4, SCL-20.5, SCL-20.6, SCL-20.7 and SCL-20.8.*
2. *While this item was carried over from the 2020 Interim Meeting, it was not a voting item and therefore not discussed during the continuation of the 2020 Annual Meeting. Instead, it was placed on the 2021 Interim Meeting’s agenda and was discussed during that meeting.*

Source:

Ross Andersen (Retired)

Purpose:

This proposal has four parts:

1. Clarify the concepts in determining error in verification,
2. Correct Code references to ensure correct reference to either e or d, as appropriate,
3. Correct Code references regarding issues of scale suitability Table 8, and
4. Explain why e and d are not connected

B2: SCL-20.3 A S.5.4. Relationship of Minimum Load Cell Verification Interval to the Scale Division

Item Under Consideration:

Amend Handbook 44, Scales Code as follows:

S.5.4. Relationship of Minimum Load Cell Verification Interval Value to the Scale Division – *The relationship of the value for the minimum load cell verification scale interval, v_{min} , to the verification scale division, d ~~e~~, for a specific scale using National Type Evaluation Program (NTEP) certified load cells shall comply with the following formulae where N is the number of load cells in a single independent¹ weighing/load-receiving element (such as hopper, railroad track, or vehicle scale weighing/load-receiving elements):*

$$(a) v_{min} \leq \frac{d e}{\sqrt{N}} \text{ for scales without lever systems; and}$$

$$(b) v_{min} \leq \frac{d e}{\sqrt{N} \times (\text{scale multiple})} \text{ for scales with lever systems.}$$

¹*“Independent” means with a weighing/load-receiving element not attached to adjacent elements and with its own A/D conversion circuitry and displayed weight.*

*[*When the value of the scale division, d, is different from the verification scale division, e, for the scale, the value of e must be used in the formulae above.]*

This requirement does not apply to complete weighing/load-receiving elements or scales, which satisfy all the following criteria:

- *the complete weighing/load-receiving element or scale has been evaluated for compliance with T.N.8.1. Temperature under the NTEP;*
- *the complete weighing/load-receiving element or scale has received an NTEP Certificate of Conformance; and*
- *the complete weighing/load-receiving element or scale is equipped with an automatic zero-tracking mechanism which cannot be made inoperative in the normal weighing mode. (A test mode which permits the disabling of the automatic zero-tracking mechanism is permissible, provided the scale cannot function normally while in this mode.*

[Nonretroactive as of January 1, 1994]

*(Added 1993) (Amended 1996, **and** 2016, **and** 20XX)*

B2: SCL-20.4 A Table 3. Parameters of Accuracy Classes.

Item Under Consideration:

Amend Handbook 44, Scales Code as follows:

| Table 3. Parameters for Accuracy Classes | | | |
|---|---|--|----------------|
| Class | Value of the Verification Scale Division e^1 (d or e^1) | Number of Scale⁴ Divisions (n) | |
| | | Minimum | Maximum |
| SI Units | | | |
| <i>I</i> | equal to or greater than 1 mg | 50 000 | -- |
| <i>II</i> | 1 to 50 mg, inclusive | 100 | 100 000 |
| <i>III</i> ^{2,5} | equal to or greater than 100 mg | 5 000 | 100 000 |
| | 0.1 to 2 g, inclusive | 100 | 10 000 |
| <i>III L</i> ³ | equal to or greater than 5 g | 500 | 10 000 |
| | equal to or greater than 2 kg | 2 000 | 10 000 |
| <i>III</i> | equal to or greater than 5 g | 100 | 1 200 |
| U.S. Customary Units | | | |
| <i>III</i> ⁵ | 0.0002 lb to 0.005 lb, inclusive | 100 | 10 000 |
| | 0.005 oz to 0.125 oz, inclusive | 100 | 10 000 |
| | equal to or greater than 0.01 lb | 500 | 10 000 |
| | equal to or greater than 0.25 oz | 500 | 10 000 |
| <i>III L</i> ³ | equal to or greater than 5 lb | 2 000 | 10 000 |
| <i>III</i> | greater than 0.01 lb | 100 | 1 200 |
| | greater than 0.25 oz | 100 | 1 200 |

¹ ~~For Class I and II devices equipped with auxiliary reading means (i.e., a rider, a vernier, or a least significant decimal differentiated by size, shape, or color), the value of the verification scale division “e” is the value of the scale division immediately preceding the auxiliary means. The manufacturer may design a scale such that the verification scale division e does not be equal to the scale division d. To ensure the correct value for e is used, refer to marking requirements in footnotes 3 and 4 to Table S.6.3.a. and Table S.6.3.b.~~
(Amended 20XX)

² A Class III scale marked “For prescription weighing only” may have a verification scale division (e) not less than 0.01 g.
(Added 1986) (Amended 2003)

³ The value of ~~a~~ **the verification** scale division (e) for crane and hopper (other than grain hopper) scales shall be not be less than 0.2 kg (0.5 lb). The minimum number of scale divisions shall not be less than 1000.
(Amended 20XX)

⁴ On a multiple range or multi-interval scale, the number of divisions for each range independently shall not exceed the maximum specified for the accuracy class. The number of scale divisions, n, for each weighing range is determined by dividing the scale capacity for each range by the verification scale division, e, for each range. On a scale system with multiple load-receiving elements and multiple indications, each element considered shall not independently exceed the maximum specified for the accuracy class. If the system has a summing indicator, the n_{max} for the summed indication shall not exceed the maximum specified for the accuracy class.
(Added 1997)

⁵ The minimum number of scale divisions for a Class III Hopper Scale used for weighing grain shall be 2000.)

[Nonretroactive as of January 1, 1986]
(Amended 1986, 1987, 1997, 1998, 1999, 2003, ~~and~~ 2004, and 20XX)

B2: SCL-20.5 A Table S.6.3.a. Marking Requirements, Note 3.

Item Under Consideration:

Amend Handbook 44, Scales Code as follows:

3. The device shall be marked with the nominal capacity. *The nominal capacity shall be shown together with the value of the scale division “d” (e.g., 15 × 0.005 kg, 30 × 0.01 lb, or capacity = 15 kg, d = 0.005 kg) in a clear and conspicuous manner and be readily apparent when viewing the reading face of the scale indicator unless already apparent by the design of the device. Each scale division value ~~or weight unit~~ with its associated nominal capacity shall be marked on multiple range or multi-interval scales. In the absence of a separate marking of the verification scale division “e” (see Note 4), the value of the verification scale division e shall be equal to the value of the scale division d.*
 [Nonretroactive as of January 1, 1983]
 (Amended 2005 and 20XX)

B2: SCL-20.6 A T.N.1.2. Accuracy Classes and T.N.1.3. Scale Division.

Item Under Consideration:

Amend Handbook 44, Scales Code as follows:

T.N.1.2. Accuracy Classes. – Weighing devices are divided into accuracy classes according to the number of scale divisions (n) and the value of the verification scale division (~~d~~) (e).

T.N.1.3. Scale Division. – **This Code contains references to two types of scale divisions, the verification scale division (e) and the scale division (d) (see definitions in Appendix D.). The tolerance for a weighing device is in the order of magnitude of related to the value of the scale division (d) or the value of the verification scale division (e) and is generally expressed in terms of ~~d~~ or e. Other technical requirements may reference either the verification scale division (e) or scale division (d) as appropriate. The values of (e) and (d) are chosen by the manufacturer and are marked on the device pursuant to S.6.3., except that d is not used in reference to an analog device, such as an equal-arm balance, where the graduations do not correspond to units of weight.**

B2: SCL-20.7 A Table 7. Maintenance Tolerances

Item Under Consideration:

Amend Handbook 44, Scales Code as follows:

| Table 6. Maintenance Tolerances (All values in this table are in <u>verification</u> scale divisions) | | | | |
|---|------------|------------------|---|---------|
| Tolerance in <u>Verification</u> Scale Divisions | | | | |
| | 1 | 2 | 3 | 5 |
| Class | Test Load | | | |
| I | 0 - 50 000 | 50 001 - 200 000 | 200 001 + | |
| II | 0 - 5 000 | 5 001 - 20 000 | 20 001 + | |
| III | 0 - 500 | 501 - 2 000 | 2 001 - 4 000 | 4 001 + |
| III | 0 - 50 | 51 - 200 | 201 - 400 | 401 + |
| III L | 0 - 500 | 501 - 1 000 | (Add 1 d e for each additional 500 d e or fraction thereof) | |

B2: SCL-20.8 A Table 8. Recommended Minimum Load

Item Under Consideration:

Amend Handbook 44, Scales Code as follows:

| Table 8. Recommended Minimum Load | | |
|--|--|---|
| Class | Value of Scale Division (d or e[±])* | Recommended Minimum Load (d or e[±])* |
| I | equal to or greater than 0.001 g | 100 |
| II | 0.001 g to 0.05 g, inclusive | 20 |
| III | equal to or greater than 0.1 g | 50 |
| III L | All** | 20 |
| III | All | 50 |
| III | All | 10 |

***For Class I and II devices equipped with auxiliary reading means (i.e., a rider, a vernier, or a least significant decimal differentiated by size, shape or color), the value of the verification scale division “e” is the value of the scale division immediately preceding the auxiliary means. For Class III and III devices the value of “e” is specified by the manufacturer as marked on the device; “e” must be less than or equal to “d.” Scales manufacturers are permitted to design scales where the value a verification scale division e differs from the displayed scale division d. If the marked value of e is less than the value of d, use e in interpreting the Table. In all other cases use the value of d. Refer to marking requirements for d and e in footnotes 3 and 4 to Table S.6.3.a. and Table S.6.3.b. (Amended 20XX)**

****A minimum load of 10 d e is recommended for a weight classifier marked in accordance with a statement identifying its use for special applications.**

(Amended 1990) **(Amended 20XX)**

Background/Discussion:

These items have been assigned to the newly formed Verification Scale Division (e) Task Group for further development. For more information or to provide comment, please contact the task group chair:

Mr. Doug Musick
 Kansas Department of Agriculture
 785-564-6681, doug.musick@ks.gov

Most scales under the Scales Code are designated by the manufacturer to have a value of e that equals d. Where e and d are not equal, there has been confusion in interpreting the Scales Code since the Code was adopted in 1984 (taking effect in 1986). This confusion came to the forefront with the needs arising from the cannabis trade. I believe that there were errors in translating OIML R76 (the basis of the current Scales Code) to HB44 format, there were key issues that were lost in translation, and finally there is misunderstanding of the HB44 Code that contributed to this confusion. My proposal will seek to identify the sources of confusion and offer revisions to make correction.

In this discussion I will be using the OIML term instrument when referencing a complete scale or weighing system. This eliminated the dual meaning of the term “device.” A device will only refer to functioning parts of an instrument. Finally, the term “scale” will not be a weighing instrument. Scale will refer only to the measurement scale, i.e. analog graduations or digital divisions.

1. Determining Error in Verification

GEN-20.1

In 2017, item 3200-7, a proposal to revise the expression of tolerances in several codes, was considered and withdrawn by the S&T Committee. The proposal aimed to correct the missing reference in those codes to errors of overregistration and underregistration. It also included a change to the definition of overregistration and underregistration that was prompted in part to a lack of understanding of the process of verification. Many of the comments received indicated that it was better handled through training. Additionally, the NCWM is working on the issue of alternative test methods which directly impacts the subject of verification. In reviewing the 2017 proposal again, I believe the real problem is a misunderstanding of the process of verification itself, stemming from a missing definition for “True Value.”

The new definition and changes to the General Code correct deficiencies in the code. The “true value” has never been clearly defined in code although it may be inferred from the definitions. The concept of true value is essential to understanding verification process as it is used throughout the Handbook. It is also a legal issue establishing the basis for tolerance decisions with the uncertain test procedure clearly stated. Our decisions are based on the true value derived from a traceable standard and not based on the standard itself. Once established, the true value is considered to have no error for purposes of legal verification. In our tests, the uncertainties in the test procedure are unquantified. If you have to defend your test in court and are asked about the uncertainty in your test, what will you answer? With the addition of the True Value definition, you have a traceable test report for your standard and the text of G-T.3. regarding the legality of the specified test procedure. The verification process formally addresses the risks in two ways. First the risks are kept small by the standard and procedure specified. Second, the risks are shared equally between buyers and sellers. The enhancements explain clearly how errors are computed and how they are interpreted.

The addition of a % error definition in G-T.3. corrects a deficiency that was identified in testing LMD’s. The tolerances in the LMD codes are expressed using errors of overregistration /underregistration (device indication – true value). Yet we in the US traditionally calculate those errors as errors of excess/deficiency (true value – device indication). When calculating % error in these calculations, it seemed appropriate to put the device indication in the denominator, but this is incorrect. All error calculations must be in terms of the true value, especially % calculations.

SCL-20.1

The addition of the Note addresses the issue of digital rounding. Parallel to R 76, the note requires errors to be determined to a resolution of at least 0.2 e. Remember that error = indication – true value, and the true value is normally the nominal value of the test weight. That means determining the indication to a resolution of 0.2 e or finer using error weights or other means when $e \geq 2d$, or by directly reading the indications when $e \geq 5d$. This means if $e = 5d$ or $e = 10d$, the indication is resolved fine enough to reduce the rounding error. In R76, the requirement is to “eliminate” rounding error, but this is not possible. You can only reduce it to 0.5 of whatever division size you resolve the indication. Hence, the proposal uses the term “reduce” instead of “eliminate.” The waiver allows field inspectors to continue to use direct reading when $e = d$, with a resulting rounding error of 0.5 e. This accepts the additional risk of passing devices outside the tolerances. (See section 4 of the proposal)

The changes to the two Scales Code tolerance paragraphs create a specific reference to the type of error in G-T.3. In this case it formally states errors are errors of overregistration/underregistration. The other change in T.1.1. addresses the missing part about applying tolerances to net values as well as gross values for unmarked scales. I believe this was just an oversight in 1984, as applying tolerances to either gross or net loads had been the established practice long before the 1984 changes to the Scales Code.

2. Correct Code references to ensure correct reference to either e or d, as appropriate.

SCL-20.2

Section S.1.2.2. is not dealing with the verification scale division e as the title implies. Instead, it is dealing with special requirements for instruments designed such that e does not equal d.

Section S.1.2.2.2. is not a specification issue directed to the manufacturer but rather a question of suitability. It should have been put into the User Requirements section 1. Selection Requirements. For a discussion of the option to delete this refer to part 4 of the proposal.

SCL-20.3

The correct value for the table is e. The use of d in the formulas only works when $e = d$. That is addressed in the note * below, which is not necessary when e is used in the formulas.

SCL-20.4

- The inclusion of references to d in the header to column 2 of the table is technically incorrect. The verification scale division must refer only to e.
- The change to Note 1 serves to eliminate the confusion about considering e to be the digit to the left of d, and ensures the e value comes from the markings on the device. It is the manufacturer who chooses e for classification purposes.
- The changes to note 3 correctly references the verification scale division e and not the scale division d, and they clean up some grammatical errors.

SCL-20.5

The change clarifies that the verification scale division is equal to the marked d when no separate marking of e is provided. Note that nothing in Note 3 prevents marking $d = 1 \text{ g}$ $e = 1 \text{ g}$, or capacity $10000 \text{ g} \times 1 \text{ g}$ $e = 1 \text{ g}$. The change to the last sentence cleans up a nonsensical term “weight unit.” The scale division must be in a unit of weight, e.g., g, kg, lb, etc. The intent was to have each range of a multi-range device include a capacity and division size n. Note R76 requires marking of Class, Max (capacity), and e, with a marking of d is only required when $e < d$

SCL-20.6

The change to T.N.1.1.2. corrects the contradiction between the current code using d and the definition using e in determining accuracy class. The value of n in the definitions already correctly refers to e

The change to T.N.1.1.3. is an attempt to clarify (e) and (d) similar to R 76 in Table 2. Note that when $e=d$, under S.6.3. only one marking is required. It is only when $e \neq d$ that S.6.3. requires both to be marked. The addition of material for ungraduated analog devices is housekeeping since d has no meaning for these devices. The change also clarifies that some requirements are directed to d (functional requirements on the device) and some to e (relating to classification and tolerance values).

3. Discuss issues of suitability of scales when e and d are not equal.

SCL-20.7

It is the value of e that is used in specifying tolerances according to the definition of e, and all values in this table must be expressed in terms of e. The table is currently written in terms of the scale division d, which is technically incorrect.

SCL-20.8

The parenthetical (d or e) in the headers to columns 2 and 3 is confusing when the two are not equal. Which one do you use? The note may address Class I and II devices, but it does not help with weight classifiers in Classes III and IIII, where you certainly don't want to use d.

It is vital to note that for instruments under R76 the manufacturer is required to mark a minimum load (Min). The manufacturer calculates Min using e. However, the minimum load is marked in mass units matching the instrument display in divisions of d. There is no confusion since it is marked on the instrument. In HB44 the inspector must determine the minimum load from Table 8 and the scale markings. Most users don't even know this requirement exists, unless told by the inspector.

Table 8 is addressing the large significance of rounding error at small loads. The be clear to ensure the correct scale division is used in enforcement. The table at the relative errors resulting from roundoff to the nearest scale division d at various table. In principle, we are trying to ensure loads weighed are sufficient to reduce errors to the levels shown, i.e. for Class I – 0.5%, for Class II – 1.0%, Class III. Class III – 2.5%, and Class IIII – 5%. While these might seem large initially, there diminishing returns effect. A small percentage of a small number tends to be insignificant. Because the value of commodities goes up as the accuracy goes up, more stringent requirements on Classes I and II.

| Load d | Relative Error |
|--------|----------------|
| 10 | 5.0% |
| 20 | 2.5% |
| 50 | 1.0% |
| 100 | 0.5% |

table must right shows loads in the the relative – 1.0%, for is a we have

Scales fall into three categories, i.e. with $e > d$, $e = d$, and $e < d$.

- If $e < d$, e.g. weight classifiers, it seems clear the appropriate choice is e. The table in the second note specifies d, which is technically incorrect. For example, a Class III weight classifier with $d = 50$ g $e = 1$ g, the relative accuracy of 5% is reached at 10 e. At 10 d or (500 e) the relative error due to rounding is 0.1%.
- If $e = d$, it doesn't matter.
- If $e > d$, on some Class I and II scales, you get the desired relative error when you use d. If you use e, the scale with $e \neq d$ will result in much smaller rounding error since the rounding is internally applied to d and not to e. Examples: If $e = 0.1$ g, then 50 e is 5 g and the rounding error is $0.5 e / 50 e = 1\%$, i.e. the desired level for Class II. If $e = 0.1$ g and $d = 0.01$ g, then 50 e is 5 g and the rounding is to 0.5 d or 0.05 e, thus the rounding error is $0.05 e / 50 e = 0.1\%$. This may be why the parenthetical (d or e) is used in the current language. Perhaps it was intended that we use the smaller value of the two if e and d are different. The proposal states e is used in cases where $e < d$ and d is used in all other cases. This eliminates any confusion. We may consider adding a marking of Min as per R76 as a future idea.

The change to the * note performs a similar function to the change in Note 1 in Table 3, as it disconnects e from d and relies solely on the markings of d and e.

In 2017, the NCWM added S.1.2.2.2. to prohibit use of Class I and II scales with a differentiated scale division. One argument was that the differentiated digit would cause confusion. There were arguments in opposition to the proposal. I argued that the confusion rested mostly with the weights and measures community (see earlier discussion). Plus, the finer digit extended the usable range of the scale since you could reach the 1% limit to rounding error at 50 d. For a Class II scale with $e = 0.1$ g and $d = 0.01$ g, that means weighing small loads down to 0.5 g loads which is something that users need in the cannabis trade.

One issue involves the rounding errors addressed in Table 8. A more critical issue view is the pricing increments. At \$30/g, represents a pricing increment of \$3. By displaying 0.01 g d, that 0.01 g d reduces increment to \$0.30. This is displayed in the right. The blue line shows the 30 cent steps use the differentiated d. If you use the digit left of the differentiated d, you see the divisions e discussed earlier. The gap the blue and red lines show the losses to they are forced to round down. The green shows pricing on a normally rounded scale 0.1 g e. The normal rounding shares the equally between buyer and seller.

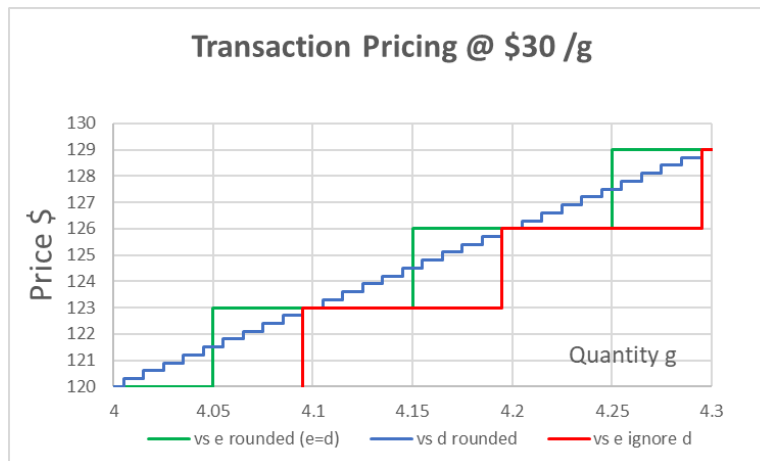

in my 0.1 g e the price graph at if you to the counted between users if line with risk

If the user must have a scale with $e = d$, then it forces them to go to 0.01 g e to service loads at the 1 g level. For that scale 50 e is 0.5 g, and the 1 g loads weighed are near 100 e. Precision scales rarely use 2 or 5 divisions, so capacities get reduced by a factor of 10 to move down to the next smaller division size. Blocking the use of $e=10d$ may force many users to purchase two scales where a single scale would have been suitable if using a scale with a differentiated d were not blocked.

4. Discussion regarding disconnecting e from d

Sections in the current Scales Code are being incorrectly interpreted to imply there is a direct connection between e and d. Essentially there is a belief when inspecting Class II scales when e does not equal d that we are somehow verifying the first digit to the left of d. Even when e = d, there is a belief that we are verifying d. That fails to follow the principles incorporated in G-T.3. We are not verifying the division; we are verifying the entire instrument indication at an applied load.

The scale division d is defined as the smallest division of the instrument under test (IUT). The scale division is referred to extensively in the code and we find that requirements written around d regulate the operating characteristics of the instrument, e.g. discrimination. When reading analog indications, we round to the nearest graduation (See Appendix A. Section 10). Under General Code G-S.5.2.2. (d), there is an important requirement that the smallest division of any digital device round off. Unless specifically designated the instruments in HB44 are in “normal rounding” class of instruments. Even with normal rounding, it is critical to understand that the digits to the left of the least significant digits are not rounded. They are counted. For example, as you count the rounded-off d’s, when you increment from 9 to 0 in the least significant digit, the next digit increments 1 digit. The break point between digits to left of the least significant digit always occurs at 9.5 d. If d is 1 g, then the tenth d is counted as 10 g and the 100th d is counted as 100 g, etc. Normal rounding of the tens place would normally occur at 5.0 d. If you attempt to apply tolerances to e and just ignore d, you are not rounding in conformance to G-S.5.2.2. (d). Instead, you are rounding down, which places the scale user at a disadvantage and disrupts equity.

UR.3.10. addresses dynamic monorail scales, which also have e and requires that the commercial transaction using these devices based on e, interpreted to mean the digit to the left of the differentiated d. These transactions therefore must be based on a counting scale (rounding down) instead of a half-up/half-down as required in G-S.5.2.2. (d). When applied to a high-priced commodity at \$30 /g, the pricing errors add up because the scale forced to always round down. The table at right shows the and this impact can be attributed to every transaction. At \$30/g, average loss to the user per transaction is \$1.35. That is not

| Indication | \$ Using d | \$ Using e | \$ gain/loss |
|------------|------------|------------|--------------|
| 0.95 | \$28.50 | \$27.00 | -\$1.50 |
| 0.96 | \$28.80 | \$27.00 | -\$1.80 |
| 0.97 | \$29.10 | \$27.00 | -\$2.10 |
| 0.98 | \$29.40 | \$27.00 | -\$2.40 |
| 0.99 | \$29.70 | \$27.00 | -\$2.70 |
| 1.00 | \$30.00 | \$30.00 | \$0.00 |
| 1.01 | \$30.30 | \$30.00 | -\$0.30 |
| 1.02 | \$30.60 | \$30.00 | -\$0.60 |
| 1.03 | \$30.90 | \$30.00 | -\$0.90 |
| 1.04 | \$31.20 | \$30.00 | -\$1.20 |
| 1.05 | \$31.50 | \$30.00 | -\$1.50 |

≠ d,
shall be
system
user is
impact,
the
equity!
device
load. If
and we
we

Verifying a scale division is virtually impossible. For a Class II the accuracy requirement is approximately 0.01% of applied the division is 0.1 g, then the required accuracy is ± 0.00001 g are trying to measure that with a resolution of 0.1 g. In addition, don’t have standards below 1 mg.

I contend that e is not the digit to the left of the differentiated d! Nor do we verify e. Careful reading of the definition of the verification scale division “e” in Appendix D will reveal no direct connection between e and the indications on the instrument being verified. The verification scale division is a mass (weight) value declared by the manufacturer in required markings that is used in classifying instruments and in specifying tolerances for the device. In the header to column 2 in Table 3., we find the expression “Verification Scale Divisions (d or e¹). This is another chance to misunderstand the Code. The verification scale division must be e according to the definition. It can’t be d, although it can have the same value as d. Similarly, reading Note 1 in Table 3, you might conclude that e is the value of the digit immediately to the left of d. The critical distinction is that e is a value of that digit and not the actual division of the display. To avoid confusion, I propose amending Table 3. to simply direct you to the scale markings to find e and remove any reference to the digit in the display.

The e value is also used in classifying instruments in the Scales Code. Classes refer to relative error ranges. This comes from the ratio MTol / e. At the second step in the tolerance structure in Table 6. Under HB44 a Class III instrument is ~0.1% accurate. This is 2 e tolerance for a load of 2,000 e. A Class II instrument is accurate to ~0.01 %, or 2 e error for a load of 20,000 e. However, the tolerances within a class are stepped, such that the % error varies through the operating range. For Class II the relative errors are 0.02% at 5,000 e, 0.01% at 20,000 e and 0.0033% at 100,000 e. The manufacturer decides what class and relative accuracy he needs to serve (based on capacity and n) and designs accordingly.

If e is not a division on the instrument, what is it? In R76, the basis of our current Scales Code, the term “scale” is not used to refer to a weighing instrument, but rather the graduations or divisions, i.e., the “scale” of indication. Thus, a scale division is not limited to weighing devices. A register on an LMD has a “scale division,” e.g., a RMFD typically indicates in 0.001 gal divisions

of scale. It should be easy to see the 0.001 gal increments correspond to d in the Scales Code. When we verify the RMFD, we use a test measure with an independent scale, either 1 in³ for older measures and 0.5 in³ for newer measures. The “verification scale” for the RMFD is therefore the “scale” on the test measure used to determine the true value. The instrument scale and the verification scale connect at only one point, at ZERO! Error arises when the two scale diverge as you move along the measurement scale due to linearity errors, influence factors, random variations, etc., within the instrument. The Verification Scale is considered to have no error.

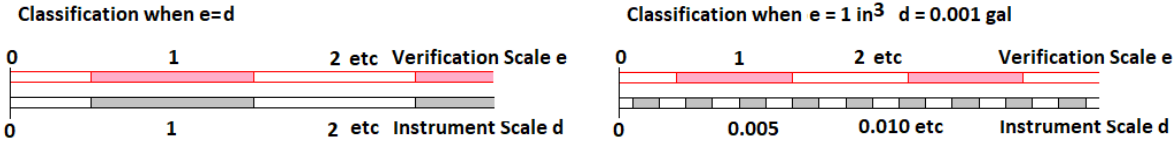

Above at left, the graphic shows a case where e = d. Notice how the divisions d and e both begin at center zero and the divisions align perfectly because at this magnification it is impossible to see small differences. The test evaluates the sum of many divisions in order to see any deviation. Above at right, the graphic shows how the 1 in³ e for the RMFD verification aligns with the 0.001 gal d of the instrument. Now imagine what happens when a test is performed.

Classification is based on relative error. This allows the verification scale division to differ from the instrument scale division, sometimes larger and sometimes smaller. With the RMFD above right, d is significantly smaller than e. In fact, the 6 e maintenance tolerance is 25 d. The two scales are independent. Would anyone suggest that the d smaller than e is inappropriate for commercial use. We verify the RMFD to e just like the weighing instrument with e = 10 d. The confusion comes from the requirement to differentiate d on these instruments.

Why does the Code require d to be differentiated when d is smaller than e? That is the critical question. It is not because d is somehow inaccurate or unreliable. It is not because d is smaller than the e of the tolerances. I believe it is because the code wanted to ensure that the serviceperson or official did not use d for tolerance calculations. It had nothing to do with users or customers.

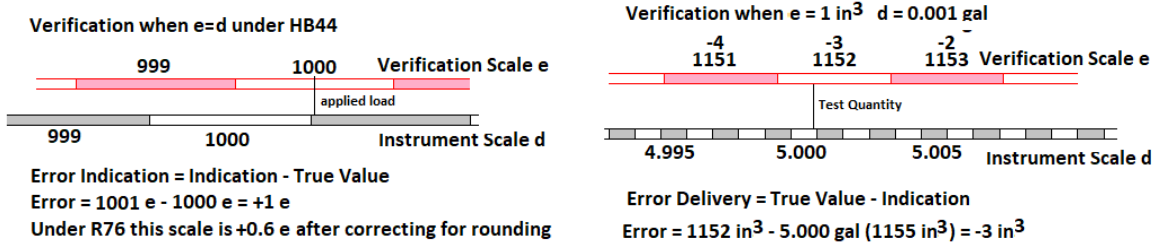

In the above graphics, the instrument scale diverges from the verification scale. They both started at the same zero reference. Notice that the RMFD at right calculates delivery error vs indication error at left. The key is to understand that the verification scale has no error and we are measuring the deviation of the instrument scale from the verification scale.

This pattern holds true for other verification tests, from tests of packaged goods with a reference scale to tests of taximeters on a road course. Circling back to the proposed definition of true value, in addition to its use in classifying scales, **the verification scale is that “scale” used to measure the true value. The division of that “true value” measurement scale is “e.”** With the new G-T.3. that true value is the legal basis of our tests and is known without uncertainty. A table of a variety of verifications and their d and e scales are provided below.

| Instrument & quantity | Instrument scale division d | Verification scale division e | Maintenance Tolerance | Ratio MT/e |
|-----------------------|-----------------------------|--|-----------------------|------------|
| RMFD @ 5 gal | 0.001 gal | 1 in ³ 0.5 in ³ | 6 in ³ | 6 12 |
| VTM @ 100 gal | 0.1 gal | 5 in ³ | ~70 in ³ | 14 |
| Rack @ 1,000gal | 1 gal | 0.1 gal | 3 gal | 30 |

| | | | | |
|-----------------------------------|------------------|-------------------------|----------------|-------|
| Mass Flow Class 0.3 | $\leq 0.2\%$ MMQ | $\leq 0.02\%$ | 0.3% | 15 |
| Taximeter @ 1 mi | 0.2 mi | ~ 0.001 mi (!5 ft) | +0.01/-0.04 mi | 10/40 |
| Package Checking @ 1 lb @ 4 oz | N/A | ≤ 0.005 lb | 0.044 lb | 8.8 |
| | N/A | ≤ 0.002 lb | 0.016 lb | 8 |
| III scale $e = d$ @ 200 d | 1 d | 1 e = 1 d | 2 e | 2 |
| III scale $e = d$ @ 2,000 d | 1 d | 1 e = 1 d | 2 e | 2 |
| II scale $e = d$ @ 20,000 d | 1 d | 1 e = 1 d | 2 e | 2 |
| II scale $e = 10 d$ @ 20,000 e | 1 d | 1 e = 10 d | 2 e | 2 |

The last column of the table is the real focus of verification. We want to have sufficient resolution in determining errors. Although the issue is a bit more complicated, this ratio is a measure of the effectiveness of the verification. Special notes:

- For the RMFD, VTM, and Rack instruments the ratio is limited by HB105-3 and the specified minimum division of the prover scale. This becomes part of the code when you specify the prover must meet that specification.
- For the mass flow instruments the Notes provide no guidance on the verification scale division. I submit the value of resolution in error should be in HB44 Notes for all Codes, similar to R76 for weighing instruments. This is something I hope the work group on alternative test methods addresses. The EPO does specify the reference scale division be no larger than 1/10 of the smallest tolerance applied. This means the Mass Flow code requires a minimum ratio of 15:1 for maintenance tolerance which I believe is overkill and very costly. Compare to 5:1 elsewhere.
- For scales the ratio is only 2:1 as currently written in Handbook 44. There is no mention of error weights in the Code. In R76, the ratio is specified in that it requires errors to be determined to at least 0.2 e. This produces a ratio of 5:1 in the first step, 10:1 in step two and 15:1 in step three. If you determine errors to 0.1 e, as we do normally with error weights, it allows you to double those ratios and provide 10:1 in the first step. Reading the errors in d when $e = 5 d$ or $e = 10d$, allows you to meet the minimum without using error weights (or expanded resolution).

Why use maintenance tolerance in computing this ratio? In verification, there is a shift in emphasis relative to calibration. In verification, your primary concern is with the population. You want all the devices in the same commercial field to have performance that is similar enough to promote equity. Even if you are little sloppy in applying acceptance tolerance, the instrument is highly likely to perform within maintenance tolerances. In calibration, the focus is always on a single artifact or instrument.

Why is this resolution in determining errors important? The short answer is to reduce the incidence of false acceptance/rejection. The Range of False Acceptance (RFA) can be defined as the portion of the compliant measured error that reaches outside the tolerance limits due to rounding in the error calculation. Limiting the RFA is the objective in specifying the resolution of errors.

When we use direct reading in testing weighing instruments the ratio of Tol:e first tolerance step is 1:1 and we have an RFA of $\frac{1}{2} e$ in proportion to the 1 e tolerance. The RFA is 50% of the tolerance, meaning we can accept instruments in error up to 1.5 times the tolerance. When we add the R76 requirement to measure errors to 0.2 e we increase the ratio of Tol:e to 5:1 and reduce the RFA to 0.1 e in proportion to the 1 e maintenance tolerance (see at right). This RFA is only 10% of the tolerance. Statistically, it can be shown RFA contributes to the population variability based on the Root Sum Square. RFA when Tol:e is 1:1, the population variability gets increased by 22%. When increase the Tol:e ratio to 5:1 the population variation is only increased by 1%, not considered significant.

A better way to express this in is terms of compliance rate. Imagine your test shows compliance of a class of devices as 95% at 1 e tolerance, but you are using direct reading. Due to rounding in measuring the error that you are not addressing, 95 % of the instruments are actually within 1.22 e and not the 1.00 indicated in the compliance data. By increasing the Tol:e ratio to 5:1, 95% of instruments are accurate within 1.01 e.

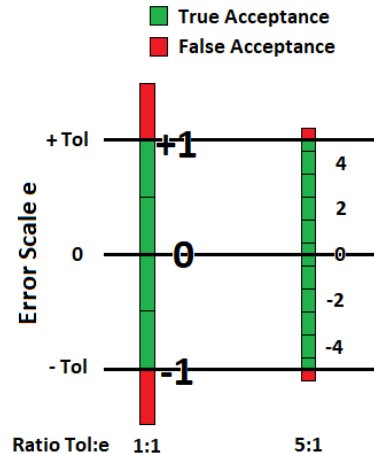

in the
thereby
graphic
that the
At $\frac{1}{2} e$
we
which is
data
testing
e
the

2020 NCWM Interim Meeting: The Committee acknowledged written comments from the submitter and heard comments during the open hearing session on this item. Mr. Constantine Cotsoradis (Flint Hills Resources) and Mr. Russ Vires (SMA) representing interests from an industry perspective questioned the need for the changes being proposed in this block of items. Additional comments from regulatory officials indicated that the changes included in this proposal were not successful in clarifying HB 44 requirements and possibly added to any confusion that exists. Mr. Steve Cook (California, retired) pointed out that the changes ignored weighing devices that did not fall under Accuracy Class I or II and stated his willingness to work with the submitter to further develop the proposal.

Several other comments heard during open hearings indicated that it is questionable to include all of the individual items that are shown as part of Block 2. Comments from SMA, and some regulatory officials recommended that this Block of items be separated since not all items now grouped under Block 2 seem to be closely related. Mr. Kurt Floren (Los Angeles County, California) also pointed out that some of the proposed amended language is not clear and will add to confusion in interpretation of requirements and that there are some editorial corrections and proper formatting needed in this proposal as well.

NIST OWM commented that while most of the proposed changes seem to be fundamentally sound, the urgent need to implement some of those proposed changes is not clear. OWM also agreed with other comments that recommend separating the items under Block 2 into individual items or grouped together where items are more clearly related. OWM notes that item SCL-20.2 now included in Block 2 is clearly related to two other items individually listed on the S&T Committee’s agenda: SCL-20.10 and SCL-20.11. Additionally, OWM believes that the determination if individual Scales Code requirements are meant to apply to either “e” or “d” should be carefully considered on a case-by-case basis. Also recommended was that additional input be solicited from stakeholders (industry officials and device manufacturers in particular) prior to adopting any changes based on this proposal.

During the Committee’s work session, they agreed that some of the items combined under Block 2 should be separated. The Committee agreed that items GEN-20.1, SCL-20.1, and SCL-20.2 should be removed from Block 2 and given individual consideration. Considering items individually, the Committee agreed to the following:

- Item GEN-20.1: The Committee acknowledged the receipt of comments from some of the regional associations concerning the use of the term “True Value” in the formulas included in parts (a) & (b) and how it is defined in the proposal. The Committee agreed that there may be value in further defining the application of tolerance and that the item should be given a Developing status adding that consideration should be given to amending the use of the term “True Value.”
- Item SCL-20.1: There were no direct comments regarding this item during open hearings. The Committee reviewed NIST OWM’s analysis on this item and agreed it should be withdrawn noting this proposed change is unnecessary.

CWMA S&T 2021 Annual Meeting Report

- Item SCL-20.2: During open hearings this item was discussed relative to items SCL-20.10 and SCL-20.11 which address the same issue. Most comments received were in favor of option 2 in this proposal which was effectively the same as SCL-20.10. The Committee agreed this item should also be withdrawn.
- Items SCL-20.3: The Committee agreed items SCL-20.4, SCL-20.5, SCL-20.6, SCL-20.7, and SCL-20.8 should be grouped together as Block 2 and given an Assigned status.

2020 NCWM Annual Meeting: Due to the 2020 Covid-19 pandemic, this meeting was adjourned to January 2021, at which time it was held as a virtual meeting. Due to constraint of time, only those items designated as 2020 Voting Items were addressed. All other items were addressed in the subsequent 2021 NCWM Interim Meeting.

2021 NCWM Interim Meeting: The Committee heard comments on this item during the open hearing session including the following.

Mr. John Barton (NIST OWM) stated that as a member of the Task Group assigned to this item, that group met on several occasions over the past 4 months to deliberate on the issues involved in this proposal. While the Task Group came to conclusions that are included in the final report, there had been other individuals and groups that came to different conclusions on those issues. Those other individuals and groups included subject matter experts, NTEP evaluators, scale manufacturers, and the NTEP Weighing Sector. Mr. Barton further stated that given the impact of changes proposed in this item, it may be wise to include additional sources of input prior to adopting the recommended changes.

It was also noted that the Committee set a date of November 15, 2023 for the Task Group to return its conclusions and that the Task Group finalized its work in a matter of 4 months rather than using the 3 years granted. It is also significant to note that the Task Group requested an Informational status for this item as opposed to a Voting status. This suggests that the Task Group is open to the notion that the proposal could be vetted further even when they have generated a “final” report on their work.

Mr. Henry Opperman (Weights and Measures Consulting) referred to the written comments he submitted to the Committee prior to this meeting and stated that all individual items in this Block should be withdrawn. Mr. Opperman stated that the proposals in this Block are based on false premises and therefore should not be adopted. Mr. Alan Walker (FL) agreed with Mr. Opperman and stated this proposal should be withdrawn also.

During the committee’s work session, the Committee considered updating the charge to the TG to direct that group to specifically identify each change recommended in the final report to actual changes proposed as amendments in HB 44. The Committee also recommends this remains as an assigned item.

Regional Association Comments:

WWMA 2019 Annual Meeting: Mr. Kurt Floren (Los Angeles County, California) stated that footnote #1 under Table 3 in item SCL-4 should have the words “be” and “to” stricken to correct grammatical errors. Mr. Kevin Merritt (ID) stated that the term “certified” as used in the proposed new language being recommended under item SCL-20.1 for Scales Code paragraph T.1. General, should be clarified/defined. He suggested the replacement of “certified” test load with language more in line with NIST traceable standards.

Regarding item SCL-20.2, Mr. Steve Harrington (Oregon) commented that still believes there is merit in the proposed changes but suggested removing the retroactive date to allow devices now in service to remain in service. Mr. Russ Vires (SMA) provided some history of the use of both “d” and “e” for scales and that field inspectors did not have the appropriate test weight to properly test these scales to the finest resolution. While supported initially by the SMA, it was not realized that this proposal would have unintended consequences related to the jewelry industry where “d” is commonly used in weight determinations. The SMA recommends that the retroactive date be eliminated to allow manufactures additional time to change the designs on their equipment and so existing scales can continue to be used. Mr. Vires also suggested that this requirement could be formatted as a user requirement.

Mr. John Barton (NIST OWM) stated that the exclusion of jeweler’s scales in this requirement could provide reason to exclude other applications and this may be a “slippery slope.”

Mr. Harrington stated that he could also support the proposal formatted as a user requirement.

The Committee agreed that this proposal does not address any known significant issues and has the potential to create additional confusion. The Committee agrees that the changes proposed are unnecessary and that the item should be withdrawn.

SWMA 2019 Annual Meeting: Ms. Diane Lee (NIST OWM) expressed concern about whether “True Value” is the appropriate term to be used in this item. Mr. Tim Chesser (Arkansas) stated that he doesn’t like the “True Value” language. Mr. Russ Vires (SMA) stated that the Scale Manufacturer’s Association has not met on this issue. Mr. Steve Benjamin (North Carolina) also pointed out two typographical errors. On page 7, lines 12 and 17, the “(+)” next to “Minus” should be changed to “(-)”. The committee would like more input from other regions on this item and recommends that it be a Developing item.

NEWMA 2018 Interim Meeting: The Committee agrees with the body that the item has merit and should be assigned a Developing status. No comments were heard during open hearings.

2020 Regional Meetings of the WWMA, NEWMA, and SWMA: These regions adhered to a condensed agenda due to the Covid pandemic and did not consider this item.

2020 CWMA Interim Meeting: The CWMA S&T Committee heard testimony from Mr. Doug Musick (Kansas and Chair of the Task Group assigned to this item) who provided an update on the TG’s progress. The CWMA S&T Committee agreed to recommend this item be retained as an Assigned item.

Additional letters, presentations and data may have been part of the Committee’s consideration. Please refer to <https://www.ncwm.com/publication-16> to review these documents.

| CWMA Report |
|---|
| Comments and justification for the regional recommendation to NCWM: <i>(This will appear in NCWM reports)</i> |
| Charlie Stutesman gave an update on the item and asked for info from the task group. Doug Musick KS provided updates from the task group and will be providing changes to the item to NCWM S&T Committee before the July Annual meeting. John Barton like the direction of the task group and reported that comments have been received. Russ Vires, SMA, stated that SMA met April 22 and supports work of the task group. The group supports continued efforts on the verification interval for "e" and scale division for "d". Loren Minnich (KS) suggested that the Block be renamed to "Verification Scale Division (e)" as the existing title is for an item that has been withdrawn. The CWMA S&T Committee recommends that this item remain an assigned item. |

SCL – SCALES

SCL-16.1 W Sections Throughout the Code to Include Provisions for Commercial Weigh-in-Motion Vehicle Scale Systems

Note: While this item was carried over from the 2020 Interim Meeting, it was not a voting item and therefore not discussed during the continuation of the 2020 Annual Meeting. Instead, it was placed on the 2021 Interim Meeting’s agenda and was discussed during that meeting.

Source:
Rinstrum, Inc. and Right Weigh Innovations (2016)

Purpose:
Recognize commercial Weigh-in-Motion vehicle scale systems.

Item Under Consideration:
Amend Handbook 44, Scales Code as follows:

S.1. Design of Indicating and Recording Elements and of Recorded Representations.

...

S.1.1.1. Digital Indicating Elements.

- (a) A digital zero indication shall represent a balance condition that is within $\pm \frac{1}{2}$ the value of the scale division.
- (b) *A digital indicating device shall either automatically maintain a “center-of-zero” condition to $\pm \frac{1}{4}$ scale division or less, or have an auxiliary or supplemental “center-of-zero” indicator that defines a zero-balance condition to $\pm \frac{1}{4}$ of a scale division or less. A “center-of-zero” indication may operate when zero is indicated for gross and/or net mode(s).
[Nonretroactive as of January 1, 1993]*

(a) Weigh-in-Motion Vehicle Scales Zero or Ready Indication.

- (1) **Provision shall be made to indicate or record either a zero or ready condition. A zero or ready condition may be indicated by other than a continuous digital zero indication, provided that an effective automatic means is provided to inhibit a measuring operation when the device is in an out-of-zero or non-ready condition.**

(Amended 1992 ~~and~~ 2008, and 20XX)

...

S.1.8. Computing Scales.

...

S.1.8.6. Values to be Recorded, Weigh-In-Motion Vehicle Scales. – At a minimum, the following values shall be printed and/or stored electronically for each vehicle weighment:

- (a) **lane identification (required if more than one lane at the site has the ability to weigh a vehicle in motion);**
- (b) **weight and sequence of each axle;**
- (c) **total vehicle weight;**
- (d) **time and date.**

(Added 20XX)

...

S.1.14. Weigh-In-Motion Vehicle Scale: Operational Limitation. - A weigh-in-motion vehicle scale shall not provide a weight indication or recorded representation if any operational limitation is exceeded.

(Added 20XX)

...

S.2. Design of Balance, Tare, Level, Damping, and Arresting Mechanisms.

S.2.1. Zero-Load Adjustment.

S.2.1.1. General. – A scale shall be equipped with means by which the zero-load balance may be adjusted. Any loose material used for this purpose shall be enclosed so that it cannot shift in position and alter the balance condition of the scale.

Except for an initial zero-setting mechanism, an automatic zero adjustment outside the limits specified in S.2.1.3. Scales Equipped with an Automatic Zero-Tracking Mechanism is prohibited.
(Amended 2010)

S.2.1.2. Scales used in Direct Sales. – A manual zero-setting mechanism (except on a digital scale with an analog zero-adjustment mechanism with a range of not greater than one scale division) shall be operable or accessible only by a tool outside of and entirely separate from this mechanism, or it shall be enclosed in a cabinet. Except on Class I or II scales, a balance ball shall either meet this requirement or not itself be rotatable.

A semiautomatic zero-setting mechanism shall be operable or accessible only by a tool outside of and separate from this mechanism or it shall be enclosed in a cabinet, or it shall be operable only when the indication is stable within plus or minus:

- (a) 3.0 scale divisions for scales of more than 2000 kg (5000 lb) capacity in service prior to January 1, 1981, and for all axle load, railway track, weigh-in-motion vehicle systems, and vehicle scales; or
(Amended 20XX)
- (b) 1.0 scale division for all other scales.

S.2.1.3. Scales Equipped with an Automatic Zero-Tracking Mechanism.

S.2.1.3.1. Automatic Zero-Tracking Mechanism for Scales Manufactured Between January 1, 1981, and January 1, 2007. – The maximum load that can be “rezeroed,” when either placed on or removed from the platform all at once under normal operating conditions, shall be for:

- (a) bench, counter, and livestock scales: 0.6 scale division;
- (b) vehicle, weigh-in-motion vehicle systems, axle load, and railway track scales: 3.0 scale divisions; and
(Amended 20XX)
- (c) all other scales: 1.0 scale division.

(Amended 2005)

S.2.1.3.2. Automatic Zero-Tracking Mechanism for Scales Manufactured on or after January 1, 2007. – The maximum load that can be “rezeroed,” when either placed on or removed from the platform all at once under normal operating conditions, shall be:

- (a) for vehicle, weigh-in-motion vehicle systems, axle load, and railway track scales: 3.0 scale divisions; and
- (b) for all other scales: 0.5 scale division.

(Added 2005)

...

S.2.5. Damping Means. – An automatic-indicating scale and a balance indicator shall be equipped with effective means to damp oscillations and to bring the indicating elements quickly to rest.

S.2.5.1. Digital Indicating Elements. – Except for weigh-in-motion vehicle systems being operated in a dynamic mode, Digital-digital indicating elements equipped with recording elements shall be equipped with effective means to permit the recording of weight values only when the indication is stable within plus or minus:

(Amended 20XX)

- (a) 3.0 scale divisions for scales of more than 2000 kg (5000 lb) capacity in service prior to January 1, 1981, hopper (other than grain hopper) scales with a capacity exceeding 22 000 kg (50 000 lb), and for all vehicle, axle load, livestock, and railway track scales; and
- (b) 1.0 scale division for all other scales.

The values recorded shall be within applicable tolerances.
(Amended 1995)

...

N.7. Weigh-in-Motion Vehicle Scale.

N.7.1. Static Testing. – A Weigh-in-Motion Vehicle Scale shall be tested statically, whenever possible, using field standard weights / test loads in accordance with Table 4, uniformly distributed on the scale platform. Additionally, for scale platforms with a length of less than 4 feet a test load not greater than one half of section capacity shall be positioned between the centerline and left and right side respectively. Scale platforms with a length of 4 feet or greater shall be tested in accordance with N.1.3.3.1. Class III acceptance and maintenance tolerance as shown in Table 6. shall apply.

N.7.2. Dynamic Testing. – The Dynamic test for a Weigh-in-Motion-Vehicle Scale shall simulate the normal intended use as closely as possible i.e. test as used. The minimum test shall consist of a vehicle(s), loaded with known field standards, dynamically weighed three consecutive times. The known field standards should then be unloaded and three additional dynamic weighments of the empty vehicle(s) should be recorded. Additionally, for scale platform widths greater than 11 feet, at least one of the loaded vehicle runs and empty vehicle runs shall be made near the left edge and right edge of the scale platform respectively. Class III acceptance and maintenance tolerance as shown in Table 6. shall apply to the known field test standards load minus the calculated value (loaded weight – unloaded weight = calculated value) the Table 6 tolerance values shall be based on the value of the known test load.

(Added 20XX)

...

T.N.3. Tolerance Values.

...

T.N.3.X. Tolerances for Weigh-in-Motion Vehicle Scales. –

T.N.3.X.1. Static Weighing. -Acceptance tolerance shall be one-half maintenance tolerance shown in Table 6. Maintenance Tolerances.

T.N.3.X.2 Dynamic Weighing. - Acceptance tolerance shall be one-half maintenance tolerance shown in Table 6. Maintenance Tolerances.

(Added 20XX)

...

UR.1. Selection Requirements. – Equipment shall be suitable for the service in which it is used with respect to elements of its design, including but not limited to, its capacity, number of scale divisions, value of the scale division or verification scale division, minimum capacity, and computing capability.¹

...

UR.1.6. Recording Element, Class III L Weigh-In-Motion Vehicle Scales. – Class III L Weigh-In-Motion Vehicle Scales must be equipped with a recording element.
(Added 20XX)

...

UR.2.6. Approaches.

UR.2.6.1. Vehicle Scales. – *On the entrance and exit end(s) of a vehicle scale, there shall be a straight approach as follows:*

- (a) the width at least the width of the platform,*
- (b) the length at least one-half the length of the platform but not required to be more than 12 m (40 ft), and*
- (c) not less than 3 m (10 ft) of any approach adjacent to the platform shall be in the same plane as the platform. Any slope in the remaining portion of the approach shall ensure (1) ease of vehicle access, (2) ease for testing purposes, and (3) drainage away from the scale.*

In addition to (a), (b), and (c), scales installed in any one location for a period of six months or more shall have not less than 3 m (10 ft) of any approach adjacent to the platform constructed of concrete or similar durable material to ensure that this portion remains smooth and level and in the same plane as the platform; however, grating of sufficient strength to withstand all loads equal to the concentrated load capacity of the scale may be installed in this portion.

[Nonretroactive as of January 1, 1976]

(Amended 1977, 1983, 1993, 2006, and 2010)

UR.2.6.2. Axle-Load Scales. – At each end of an axle-load scale there shall be a straight paved approach in the same plane as the platform. The approaches shall be the same width as the platform and of sufficient length to insure the level positioning of vehicles during weight determinations.

UR.2.6.3. Weigh-in-Motion Vehicle Scales. - At each end of a Weigh-in-Motion Vehicle Scale there shall be a straight approach in the same plane as the platform. The approaches shall be the same width as the platform and of sufficient length to insure the level positioning of vehicles during weight determinations. Both approaches shall be made of concrete or similar durable material (e.g., steel).
(Added 20XX)

...

UR.3.2. Maximum Load. – A scale shall not be used to weigh a load of more than the nominal capacity of the scale.

¹ Purchasers and users of scales such as railway track, hopper, and vehicle scales should be aware of possible additional requirements for the design and installation of such devices.

(Footnote Added 1995)

UR.3.2.1. Maximum Loading for Vehicle Scales. – A vehicle scale shall not be used to weigh loads exceeding the maximum load capacity of its span as specified in Table UR.3.2.1. Span Maximum Load.

(Added 1996)

Note: UR.3.2.1. is not applicable to Weigh-In-Motion Vehicle Scales.
(Added 20XX)

...

UR.3.3. Single-Draft Vehicle Weighing. A vehicle or a coupled-vehicle combination shall be commercially weighed on a vehicle scale only as a single draft. That is, the total weight of such a vehicle or combination shall not be determined by adding together the results obtained by separately and not simultaneously weighing each end of such vehicle or individual elements of such coupled combination. However, the weight of:

- (a) a coupled combination may be determined by uncoupling the various elements (tractor, semitrailer, trailer), weighing each unit separately as a single draft, and adding together the results; or
- (b) a vehicle or coupled-vehicle combination may be determined by adding together the weights obtained while all individual elements are resting simultaneously on more than one scale platform.

Note: This paragraph does not apply to **weigh-in-motion vehicle scales**, highway-law-enforcement scales and scales used for the collection of statistical data.

(Added 1992) **(Amended 20XX)**

...

UR.3.7. Minimum Load on a Vehicle Scale or Weigh-in-Motion Vehicle Scale. – A vehicle scale **or weigh-in-motion vehicle scale** shall not be used to weigh net loads smaller than:

- (a) 10 d when weighing scrap material for recycling or weighing refuse materials at landfills and transfer stations; and
- (b) 50 d for all other weighing.

As used in this paragraph, scrap materials for recycling shall be limited to ferrous metals, paper (including cardboard), textiles, plastic, and glass.

(Amended 1988, 1992, ~~and~~ 2006, **and 20XX**)

...

UR.3.9. Use of Manual Weight Entries. – Manual gross or net weight entries are permitted for use in the following applications only when:

- (a) a point-of-sale system interfaced with a scale is giving credit for a weighed item;
- (b) an item is pre-weighed on a legal for trade scale and marked with the correct net weight;
- (c) a device or system is generating labels for standard weight packages;
- (d) postal scales or weight classifiers are generating manifests for packages to be picked up at a later time; or
- (e) livestock and vehicle scale **or weigh-in-motion vehicle scale** systems **that** generate weight tickets to correct erroneous tickets.

(Added 1992) (Amended 2000 ~~and~~ 2004, **and 20XX**)

Background/Discussion:

These items have been assigned to the Weigh-in-Motion (WIM) Task Group for further development. For more information or to provide comment, please contact:

Co-Chair

Mr. Alan Walker
Florida Dept. of Ag. and Consumer Services
850-274-9044, alan.walker@fdacs.gov

Co-Chair

Mr. Tim Chesser
Arkansas Bureau of Standards
501-570-1159, tim.chesser@aspb.ar.gov

Rinstrum and Right Weigh Innovation (manufacturers of weigh-in-motion vehicle scale systems) submitted a proposal in 2016 to modify the tentative WIM Code for Screening and Sorting. The original purpose of this item was to recognize a higher accuracy class and appropriate requirements in Section 2.25. Weigh-In-Motion Systems Used for Vehicle Enforcement Screening Tentative Code by adding commercial and law enforcement applications. Specifically, WIM vehicle scale systems capable of performing to within the tolerances specified for a higher accuracy class would be permitted for use in commercial applications and for highway law enforcement.

In February 2016, the NCWM agreed to form a task group (TG), at the recommendation of the Committee, to consider a proposal that would expand the new NIST Handbook 44 Weigh-In-Motion Systems Used for Vehicle Enforcement Screening – Tentative Code to also apply to commercial use. Mr. Alan Walker (FL) agreed to serve as chairman of the new TG. The WIM Task Group (TG), however, agreed in 2016 that it would be more appropriate to address these higher accuracy WIM systems by proposing changes to Section 2.20. Scales Code, which remains the current effort of the TG.

Information and details on the TG's work and any updates on progress made during 2016-2018 can be found in the S&T Committee's Final Reports for that time period.

2019 NCWM Interim Meeting: The Committee heard testimony from Mr. Walker indicating that the submitter has prepared for collecting data that would provide evidence that the Rinstrum WIM system can comply with the stated tolerances in the proposal. Currently, the TG has not been able to observe any data collection or receive conclusive results. During the committee's work session, the Committee agreed to maintain the Assigned status for this item.

2019 NCWM Annual Meeting: The Committee received an update from Mr. Walker stating that the submitter, Rinstrum had completed the installation of a WIM system to be used to provide data and evidence to support the submitter's claims regarding these system's performance capabilities. However, the TG has yet to witness any of the data being collected. Upon the request of the TG's Co-Chair, the Committee agreed to maintain the Assigned status of this item.

2020 NCWM Interim Meeting: Mr. Tim Chesser (Arkansas and WIM TG Co-Chair) stated that there is nothing new to report and that the TG has not met since August 2019. Mr. Brad Fryburger (Rinstrum) stated that the trials the submitter has been performing to generate data regarding the performance capabilities of the submitter's system has not reached a point where 100 % of trial runs over the system have met Class III L tolerances. Noting that there can be many variables that could cause the results to fall outside the allowable tolerances, Mr. Fryburger stated that he was not yet able to eliminate all sources of detrimental influences during the test runs.

Mr. Lou Sakin (Massachusetts) noted that this item has been on the Committee's agenda for 5 years and seems to be at a standstill. Without evidence that the TG is making further progress, he recommended the item be returned to the submitter for further development or withdrawn.

NIST OWM stated that the TG has requested data to support the submitter's claims their system will meet HB 44 Scales Code Class III L tolerances. The submitter had made previous statements indicating that the collection of this type of data could be witnessed by members of the TG and/or Committee members. OWM pointed out this has not yet happened and that further work by the TG was dependent on the collection of this data.

Mr. Charles Stutesman (KS), Mr. Kevin Schnepf (CA), and Mr. Russ Vires (SMA) recommended this item be withdrawn due to a lack of further development. Mr. Richard Suiter (Richard Suiter Consulting) pointed out that the TG has done a great deal of work on amending the HB44 Scales Code to apply to these WIM systems and that this work should not be disregarded. Mr.

Suiter pointed out that the TG's work could also benefit other manufacturers of WIM systems and therefore has value and suggested this item be put forward as a voting item or allow it to continue as assigned to the TG.

During their work session, the Committee agreed this proposal is not fully developed and will remain assigned to the WIM Task Group (WIM TG).

Evidence of devices which are capable of compliance with Class III L tolerances must be provided to the WIM TG by June 12, 2020.

The collection of data, which can be presented as evidence of compliance with class III L tolerances, is to be witnessed by members of the S&T Committee and/or WIM TG members.

The data collection procedure is to include a minimum of three passes with three trucks (total of 9 weighments) over a WIM scale using 3 separate and different motor vehicles (representing the range of weighments expected during typical use) to be considered as evidence that a WIM scale system is capable of compliance with Class III L tolerances.

2020 NCWM Annual Meeting: Due to the 2020 Covid-19 pandemic, this meeting was adjourned to January 2021, at which time it was held as a virtual meeting. Due to constraint of time, only those items designated as 2020 Voting Items were addressed. All other items were addressed in the subsequent 2021 NCWM Interim Meeting.

2021 NCWM Interim Meeting: The Committee heard testimony from Mr. John Barton (NIST OWM) pointing out that there has been no activity from the Task Group assigned to this proposal and that this item has been on the Committee's agenda for almost five years. Also noted was that the submitter was granted a previous extension (until December 2020) to produce evidence justifying additional work by the Task Group. Mr. Alan Walker (Florida and Co-Chair of the Task Group) stated that there has been no recent activity and requested that the Committee provide an extension that will allow the submitter additional time to produce the requested evidence of the system's performance. Mr. Walker stated that the submitter should be given until the 2021 NCWM Annual Meeting to produce the necessary data.

Mr. Dick Suiter (Richard Suiter Consulting) stated that he had spoken with the submitter and was told that the testing being done is producing results showing their system is generating a 98 % accuracy.

Mr. Russ Vires (SMA) recommends the proposal's withdraw. Noting the amount of time this item has been on the Committee's agenda, also recommending withdraw was Mr. Charlie Stutesman (Kansas) and Mr. Tim Chesser (Arkansas and Co-Chair of the Task Group) who additionally acknowledged the work done to this point by the Task Group. Mr. Kevin Schnepf (CA) also recommended withdraw of the item.

Mr. Brad Fryburger (Southern Illinois Scale, representing the submitter) stated that he expects Rinstrum's system will soon be ready and available to demonstrate the claims regarding the performance of the system. Provided his expectation is realized, Mr. Fryburger recommended a Developing status.

At the Committee's work session, it was decided based upon the length of time this proposal has been on the agenda to Withdraw the item. The Committee also noted that a submission of a new proposal from the submitter would be welcome when the item is deemed ready to move forward.

Regional Association Comments:

WWMA 2019 Annual Meeting: Mr. Russ Vires (SMA) does not support the proposal as written, the SMA has submitted written comments in opposition to this item. Mr. John Barton (NIST OWM) informed the WWMA that a commitment made by the submitter to provide an opportunity to members of the TG to witness data collection that will provide evidence that their device is capable of meeting the HB 44 Scales Code Class III L tolerances has not been met. As a member of the WIM TG, it is necessary to have evidence through the collection of test data showing that the submitter's device will meet the claimed performance and that the efforts of the TG are justified and worth continuing.

The WWMA recommends this item be withdrawn due to the lack of substantiated evidence that the submitter's claims of their device performance capabilities can be validated.

SWMA 2019 Annual Meeting: Mr. Tim Chesser (WIM Task Group Co-Chair) stated that the WIM Task Group is awaiting direction from the National S&T Committee on this item. Mr. Russ Vires (SMA) stated that he opposes the item as written. Mr.

Eric Golden (Cardinal Scale) asked if additional testing had been completed. Mr. Alan Walker (WIM Task Group Co. Chair) stated that additional testing had not yet been completed, and that they were currently waiting on direction from the chair of the National S&T Committee.

The SWMA recommends this item remain Assigned, while the WIM Task Group awaits further testing.

NEWMA 2019 Interim Meeting: The NEWMA agrees with the body that this item has merit and should remain Assigned. During open hearing, the NEWMA heard comments from Mr. Dick Suiter (Richard Suiter Consulting) as a WIM Task Group member. He indicated that TG is waiting for more direction from S&T committee. The major concerns are that test data given by submitter was not witnessed by a weights and measures official.

2020 Regional Meetings of the WWMA, NEWMA, and SWMA: These regions adhered to a condensed agenda due to the Covid pandemic and did not consider this item.

2020 CWMA Annual Meeting: The CWMA S&T Committee heard from both regulatory officials and industry representatives requesting this item be withdrawn for lack of progress. Loren Minnich (Kansas & NCWM S&T Chair) advised that Rinstrum, Inc. has been given a deadline of December 2020 to produce the data that has been requested by the WIM Task Group. We feel that due to a lack of progress on this item, the CWMA recommends the item be withdrawn.

Additional letters, presentations and data may have been part of the Committee’s consideration. Please refer to <https://www.ncwm.com/publication-16> to review these documents.

| |
|--|
| CWMA Report |
| Comments and justification for the regional recommendation to NCWM: <i>(This will appear in NCWM reports)</i> |
| No comments on withdrawn items. |

SCL-17.1 V S.1.8.5. Recorded Representations, Point of Sale Systems

This item was designated as a “Voting” item by the Committee at the 2020 NCWM Interim Meeting. The NCWM was unable to hold an Annual Meeting in July 2020 due to restrictions of the COVID-19 pandemic. The NCWM was able to hold a virtual continuation of the 2020 Annual Meeting in January 2021 during which it conducted a vote on items designated as “Voting” on the Committee’s 2020 Agenda. This item was NOT supported with a positive vote by those attending that January 2021 meeting.

Source:

Kansas and Minnesota

Purpose:

Provide consumers the same opportunity, to be able to easily verify whether or not tare is taken on items weighed at a checkout stand using a POS system, as has currently afforded them when witnessing items being weighed and priced in their presence using other scales in the store.

Item Under Consideration:

NOTE: At the 2020 NCWM Interim Meeting the Committee supported the Non-retroactive version for changes to this item.

Amend Handbook 44, Scales Code as follows:

S.1.8.5. Recorded Representations, Point-of-Sale Systems. – The sales information recorded by cash registers when interfaced with a weighing element shall contain the following information for items weighed at the checkout stand¹:

- (a) the net weight;¹
- (b) the unit price;^{1,2}
- (c) the total price; **and**
- (d) the product class or, in a system equipped with price look-up capability, the product name or code number; **and**

(e) the tare weight.

[Non-retroactive as of January 1, 2024]

(Amended 2021)

¹Weight values shall be **identified as tare and net, or gross if applicable. The unit of weight shall be identified by as** kilograms, kg, grams, g, ounces, oz, pounds, or lb. ~~The “#” symbol is not acceptable.~~

~~*[Nonretroactive as of January 1, 2006]*~~

²For devices interfaced with scales indicating in metric units, the unit price may be expressed in price per 100 grams.

(Amended 1995, ~~and 2005,~~ and 2021)

²For devices interfaced with scales indicating in metric units, the unit price may be expressed in price per 100 grams.

(Amended 1995, ~~and 2005,~~ and 20XX)

Background/Discussion:

This item has been assigned to the Point-of-Sale Tare Task Group (POST) for further development. For more information or to provide comment, please contact the task group chair:

Mr. Loren Minnich
Kansas Department of Agriculture
785-564-6695, Loren.Minnich@ks.gov

The submitters of this proposal state that it will benefit consumers by enabling them to see at a glance that tare is being taken on the commodities they purchase. It would also educate the public about tare and make them better and more aware consumers.

Additionally, it is purported that retailers would benefit because this proposal would aid their quality control efforts behind the counter and at the cash register. Retailers would be able to see that their employees are taking tare on packages, and that the tare employees take is the appropriate tare.

Finally, this proposal would aid weights and measures officials investigating complaints about net contents of item by creating written proof of how much tare was taken on a given package or transaction.

Scale manufacturers will need to modify software and label and receipt designs before the non-retroactive date. Retailers with point of sale systems and packaging scales may feel pressured to update software or purchase new devices in response to consumer demand for tare information on labels and receipts. The amount of paper needed to print customer receipts may increase depending on the formatting of the information and the size of the paper being used. Some retailers may not want consumers to have this information as it will allow consumers and weights and measures officials to hold them accountable and would be written proof tare was not taken when, and if, that happens.

2018 NCWM Interim Meeting: The Committee heard from Mr. Loren Minnich (KS) who commented that the item will benefit consumers and asked the Committee to move the item forward as a voting item. Many comments both in support of and in opposition to the proposal were heard. The Committee also received a written recommendation asking the Committee to consider modifying the proposal to: (1) require the tare weight and/or the gross weight be printed on the receipt; (2) clarify printed weight values must be clearly and definitely identified as gross, tare, and/or net weights (as required by the General Code); and (3) move text currently in a footnote to the paragraph into the body of the paragraph for ease of reference.

During the Committee’s work session, the committee members reviewed all information received and agreed to move the item forward as a “Voting” item without change.

2018 NCWM Annual Meeting: The Committee agreed to assign the further development of this item to an NCWM task group (TG) and established that the goal of this task group should be to determine how to provide consumers (and operators) with the information necessary, whether on a receipt or displayed on the POS system itself, to verify that charges for items weighed at checkout are based on net weight, similar to the opportunity provided them by retail-computing scales used in direct sale applications.

The Committee also received several comments in opposition including a comment from Mr. Russ Vires (Mettler-Toledo, LLC), speaking on behalf of the SMA, stating that the SMA opposes the agenda item and feels it would be too costly to implement with little benefit. Additionally, the Committee received written comments including those from Ms. Elizabeth K. Tansing, on behalf of the Food Marketing Institute, opposing the item and requesting that the Committee withdraw the proposal. During the committee's work session, the proposal was amended to only include changes to paragraph S.1.8.5. and to include a nonretroactive enforcement date of January 1, 2020.

The Committee received numerous comments on this item suggesting additional work is needed to further develop the proposal and recommending a new task group made up of regulatory officials, food marketing representatives, POS software programmers, NIST, and others. Two of the original submitters of the item, Ms. Julie Quinn (Minnesota) and Mr. Loren Minnich (Kansas) spoke in favor of assigning the item to a work group; one noting that the complexities of packaging are more involved today than first realized indicating the need for this proposal to be looked at more in depth.

The Committee also received numerous written letters from the grocery store industry opposing the item and requesting that the Committee withdraw it to include: the NC Retail Merchants Association, FL Retail Federation, SC Retail Association, Food Marketing Institute (FMI), and others. In consideration of the number of comments received on this item in support of its further development by a work group, the Committee agreed to recommend this item be assigned to an NCWM Task Group (TG).

2019 NCWM Interim Meeting: The Chairman of the NCWM POS Tare Task Group, Mr. Loren Minnich (Kansas), provided an update of the Task Group's activities since it first formed following the 2018 NCWM Annual Meeting. He reported the main topics of discussion thus far have been:

- whether the addition of proposed part (e) to paragraph S.1.8.5., which adds "tare weight" to the list of required information printed on a receipt should remain non-retroactive, as submitted, or be changed, per NIST OWM's suggestion, to retroactive with an effective date ten years from the date of adoption; and
- which value should be added to the receipt, "tare" or "gross" weight?

Mr. Minnich recommended this item remain in an Assigned status given members of TG have been unable to reach a consensus on these issues. Cost of compliance is a concern. The Committee, in consideration of the comments received on this item, agreed with the recommendation of the POS Tare TG Chairman to maintain the Assigned status of the item to allow the TG more time for further discussion and development.

2019 NCWM Annual Meeting: The POS Tare TG Chairman provided the Committee with an update on the TG's progress and presented two amended versions of S.1.8.5. and associated footnotes for the Committee to consider. Those two versions are shown under the Item Under Consideration.

The Chair of the assigned TG reported that members of the TG believe both versions of the amended S.1.8.5. are fully developed, but they were unable to agree on which version should be presented for final consideration. Both versions are being offered so that feedback can be solicited from the fall regional weights and measures associations. It is hoped this feedback will help the Committee to decide the most favorable version.

2020 NCWM Interim Meeting: Most comments received supported the non-retroactive version included in Pub 15 since it will allow the business affected to choose when to comply and would provide the consumer confirmation that tare was deducted. The Committee heard comments in opposition to the proposal from Mr. Russ Vires (SMA) believing the changes recommended will do little if anything to assist the consumer and that field officials are already performing inspections to verify that correct tare is taken in transactions where the item is sold by weight. Comments were also heard regarding the new abbreviations being proposed in this item. The concern was that they could be misinterpreted as something else (e.g., TA for taxable item). Mr. Tim Chesser (Arkansas) added that he did not believe there was any significant benefit to the proposed changes but added that identifying "gross," "net," or "tare" on a receipt using (respectively) "g," "n," or "t" is not an acceptable means to identify these terms. Mr. Jim Willis (New York) stated his opposition to the proposal believing that adding tare to the customer's receipt wouldn't ensure that the tare deducted is correct if not verified.

2020 NCWM Interim Meeting: Most comments supported the non-retroactive version included in Pub 15 because it would allow the business affected to choose when to comply and would provide the consumer confirmation that tare was deducted.

NIST OWM did not state any preference as to whether the “nonretroactive” or “retroactive” version of the proposal should be favored but noted it is important that the consumer be given the opportunity to verify that items sold by weight are priced according to “net” weight. This would be easily done by including information on the receipt showing that tare has been deducted from the gross weight prior to calculating the total sale. We acknowledge that not all consumers will have this concern when purchasing items sold by weight however, those consumers that are interested in verifying the terms of sale must be afforded the information that will help them do that. OWM also notes that opposition to this proposal has cited costs involved with compliance to this proposal as one reason not to adopt it however, we are not aware of any cost analysis that has been done to verify this claim.

Mr. Chesser noted that receipts provided from sales in some retail locations are exceedingly long and include extraneous information not relevant to the sale. If placing all of this information on the receipt is being done, how much effort and cost could it be to simply add a value for the tare weight used during the sale? Mr. Charles Stutesman (Kansas) stated his support for the nonretroactive version of the proposal and also questioned the claims of these changes being too costly to implement.

Ms. Fran Elson-Houston (Ohio) commented that devices that already have been given a NTEP Certificate of Conformance may need to undergo a subsequent evaluation since the changes in this proposal would be accomplished through software changes in those devices. Mr. Darrell Flocken (NTEP) stated that if the device/system is already calculating total sale prices, there would be no need to reevaluate the devices following the adoption of this proposal. Mr. Steve Harrington (Oregon) stated his concern for small retail operations that do not have the resources of the big chain stores to enable a quick change in their software. He would be more willing to support the proposal if there was consideration given to allow a more gradual phase-in period for compliance by smaller businesses.

Other regulatory officials voiced their support for the nonretroactive version of the proposal noting that small businesses would not immediately be affected. Mr. Loren Minnich (Kansas) stated that was the rationale behind the development of a nonretroactive version. He also stated that if the Committee agrees to move the nonretroactive version forward as a voting item, there will need to be an effective date assigned to the requirement.

During the Committee’s work session, the Committee assigned a voting status to the non-retroactive version below:

S.1.8.5. Recorded Representations, Point-of-Sale Systems. – The sales information recorded by cash registers when interfaced with a weighing element shall contain the following information for items weighed at the checkout stand¹:

- (a) the net weight;[†]
- (b) the unit price;^{‡2}
- (c) the total price; **and**
- (d) the product class or, in a system equipped with price look-up capability, the product name or code number;[‡]
and
- (e) the tare weight.***

***[Non-retroactive as of January 1, 20XX]
(Amended 20XX)***

FOOTNOTES 1 AND 2 FOR EITHER VERSION (RETROACTIVE OR NONRETROACTIVE)

¹Weight values shall be **adequately defined as gross, tare, and/or net upon any two or more of these values appearing on the receipt. Acceptable abbreviations include, but are not limited to, G & GR (gross), & TA (tare), and N & NT (net). The unit of weight shall be identified by as kilograms, kg, grams, g, ounces, oz, pounds, or lb. The “#” symbol is not acceptable.**
[Nonretroactive as of January 1, 2006]

²For devices interfaced with scales indicating in metric units, the unit price may be expressed in price per 100 grams.
(Amended 1995, **and** 2005, **and** 20XX)

During the discussion of this item at the 2020 Annual Meeting the S&T Committee presented an amended version of the item

which differed from the item included in Publication 16. The amended item presented during open hearing is shown below:

S.1.8.5. Recorded Representations, Point-of-Sale Systems. – The sales information recorded by cash registers when interfaced with a weighing element shall contain the following information for items weighed at the checkout stand¹:

- (a) the net weight;¹
- (b) the unit price;^{1,2}
- (c) the total price; ~~and~~
- (d) the product class or, in a system equipped with price look-up capability, the product name or code number;~~;~~
and
- (e) the tare weight.*

[Non-retroactive as of January 1, 2024]
(Amended 2021)

¹Weight values shall be adequately defined as gross, tare, and/or net upon any two or more of these values appearing on the receipt. Acceptable abbreviations include, but are not limited to, G & GR (gross), T & TA (tare), and N & NT (net). The unit of weight shall be identified by as kilograms, kg, grams, g, ounces, oz, pounds, or lb. ~~The “#” symbol is not acceptable.~~
[Nonretroactive as of January 1, 2006]

²For devices interfaced with scales indicating in metric units, the unit price may be expressed in price per 100 grams. (Amended 1995, ~~and~~ 2005, and 2021)

The amendments were made to italicize a portion of the requirement (e) shown above, clarifying it as a nonretroactive requirement, and to add a nonretroactive date that would make the item effective three years after adoption. The following comments were received during the open hearing session at the 2020 Annual Meeting regarding the amended item related to footnote one:

- the abbreviations of G or GR, N or NT, and T or TA were not descriptive enough and may lead to confusion;
- the phrase “adequately defined” may need to be replaced to more clearly require weight values to be classified as gross, net, or tare; and
- it is questionable whether to strike the statement prohibiting the # symbol to designate “pounds.”

These concerns were taken into consideration and the item was amended further by the Committee. The version listed under the Item Under Consideration heading above was presented for a vote.

There were comments received both in support and opposition of the adoption of this item. The following were cited as reasons to support adoption:

- In 1973 the S&T Committee expressed the opinion that the information available on a computing scale should also be available to the consumer when purchasing an item weighed at the checkstand (i.e., on a POS).
- There are already versions of POS software which are currently capable of including tare on the printed receipt.
- This change would provide consumers a record of the sale and the ability to determine if tare was deducted as required.
- The record of sales would provide weights & measures officials with additional information to investigate complaints related to net weight issues.
- Tare values are displayed on many stand-alone Retail Computing Scales during direct sales and consumers should have a similar opportunity to verify net weight on a POS used at the checkout.
- Tare inspections may or may not be a routine practice for all jurisdictions, and when programmed tare is checked by regulators there are frequent issues found.

CWMA S&T 2021 Annual Meeting Report

- When items are weighed at the checkout station, the consumer is not normally provided an adequate opportunity to verify if they are charged the correct net weight because the weighing process occurs so quickly.
- Scales interfaced with cash registers typically provide a display of the live gross weight, but the weight value isn't identified as a gross weight which can be confusing to consumers.
- This change may be an incentive to retailers to keep tares updated correctly.
- Consumers that understand the weighing process would benefit from adding tare to the receipt giving them confidence that the item was sold by net weight.
- Marketing practices have changed in grocery stores and there are now multiple forms of packaging available which have various tare weights, the "standard" 0.01 lb tare is no longer sufficient by itself to ensure a net weight determination.
- Due to multiple values of tare used, additional challenges to correctly process a weighing transaction are involved including the following.
 - Some items may need multiple Product Look-Up (PLU) codes to properly determine net weight.
 - The tare for certain PLU's must be programmed to deduct the largest tare value to ensure sales by net weight.

A number of reasons were stated during open hearing session in opposition for adoption including the following.

- Adding tare to the receipt may cause consumer confusion.
- There may be complaints received from consumers who think they were charged for tare.
- Adding tare won't benefit the consumer because weights and measures agencies already check tare during routine inspections and therefore tare values should be correct.
- No complaints have been cited regarding tare values not being included on the receipt.
- Including tare won't mean that the value is correct, but including tare on the receipt may lead consumers to assume the weighing process was performed correctly.

2020 NCWM Annual Meeting: Due to the 2020 Covid-19 pandemic, this meeting was adjourned to January 2021, at which time it was held as a virtual meeting. Due to constraint of time, only those items designated as 2020 Voting Items were addressed. All other items were addressed in the subsequent 2021 NCWM Interim Meeting.

2021 NCWM Interim Meeting: Since this item was considered during the 2020 Annual Meeting, the Committee heard no additional comments on this item during the 2021 Interim Meeting open session. At the committee's Interim Meeting work session, the Committee recognized this was the second time in January 2021 this item was considered. During the 2021 Interim Meeting the Committee agreed to maintain the voting status believing that the last-minute changes made by the Committee during the 2020 Annual Meeting was the primary cause the item failed to be adopted during the voting session.

Regional Association Comments:

WWMA 2018 Annual Meeting: Mr. Russ Vires (SMA) reported the SMA had provided a position from their 2019 April meeting stating that this proposal would provide little if any benefit to the consumer. Mr. John Barton (NIST OWM) stated that to not provide some indication to the consumer that tare has been taken violates the principle behind the General Code requirement G-S.5.1. That requirement states that weight indications for commercial transactions be clear, definite, and easily read. The consumer deserves to be assured that the commodity is being sold by net weight and that appropriate tare has been deducted. He also noted that the TG assigned to this item has offered two versions of the proposal. One is non-retroactive version and the other is a retroactive version. The Committee is encouraged to consider the implications of the status for the proposed requirement. The retroactive version will require that all POS systems comply with the requirement, and the non-retroactive version would allow those systems that are currently in service to be grandfathered. Mr. Kurt Floren (L.A. County, CA) stated he supports the retroactive version of this proposal if it is not cost-prohibitive however, he does oppose the item even if the proposal was adopted as non-retroactive. He also recommended that the term "defined" as it appears in both versions of this proposal should be replaced with "indicated" or "designated." Mr. Steve Harrington (OR) stated he was concerned with the potential that smaller businesses will need to absorb the cost to comply with the requirement if the retroactive version was adopted.

The Committee agreed to support the non-retroactive version of this item as proposed in the item under consideration. The Committee also deliberated on the establishment of an effective date for the non-retroactive requirement. The Committee agreed to recommend that the effective date be January 1, 2024.

The Committee agrees that this item be given a voting status and recommends that additional input be solicited from the other regional associations and that input then be forwarded to the NCWM S&T Committee.

SWMA 2019 Annual Meeting: Mr. Russ Vires (SMA) opposed this item on the grounds that it provides no benefit to the consumer. The Committee recommends the non-retroactive version of this item be made a Voting Item.

NEWMA 2019 Interim Meeting: The Committee agrees with the body that the changes proposed are unnecessary and that the item should be withdrawn. During open hearings, the Committee heard from Mr. Jim Willis (NY) who believes the proposal will cause consumer confusion because while the tare is printed, there is no guarantee that it will be correct. Mr. John McGuire (NJ) agrees with the comments from New York.

2020 Regional Meetings of the WWMA, NEWMA, and SWMA: These regions adhered to a condensed agenda due to the Covid pandemic and did not consider this item.

2020 CWMA Annual Meeting: The CWMA S&T Committee heard comments in opposition from the SMA. Many regulatory officials made comments in support of the item. The CWMA recommends the item moving forward as a voting item with the proposed amendments by the NCWM S&T Committee.

Additional letters, presentations and data may have been part of the Committee’s consideration. Please refer to <https://www.ncwm.com/publication-16> to review these documents

| CWMA Report |
|--|
| Comments and justification for the regional recommendation to NCWM: <i>(This will appear in NCWM reports)</i> |
| Loren Minnich, KS believe that this provides more equity so that information is provided on the receipt, all deli scales indicate tare having it placed on the ticket provides more equity. Russ Vires, SMA continues to oppose this item. They feel that this provides little or no value to the consumer. John Barton, NIST OWM there is only one additional piece of information added and feels that does not create confusion, but creates more transparency in the transaction. Doug Musick stated Russ Vires is correct that some states do check Price Look Up entry, but most are not checking that the right tare is taken when purchases are made. The CWMA S&T Committee recommends that this item moves forward as a voting item. |

SCL-21.1 W S.1.1. Zero Indication

Source:
Town of Wellesley, Massachusetts

Purpose:
With the implementation of screen savers, power savers and text on the displays of automatic-indicating scale or balance indicators the consumer and merchant cannot always see the automatic numerical zero prior to the beginning of a transaction. This proposal is correct that situation.

Item Under Consideration:
Amend NIST Handbook 44, Scale Code as follows:

S.1. Design of Indicating and Recording Elements and of Recorded Representations.

S.1.1. Zero Indication.

- (a) On a scale equipped with indicating or recording elements, provision shall be made to either indicate or record a zero-balance condition.

- (b) On an automatic-indicating scale or balance indicator, provision shall be made to indicate or record an out-of-balance condition on both sides of zero.
- (c) A zero-balance condition ~~may shall~~ be indicated by ~~other than~~ a continuous digital zero indication on both sides of an automatic-indicating scale or balance indicator, provided that an effective automatic means is provided to inhibit a weighing operation or to return to a continuous digital indication when the scale is in an out-of-balance condition.

(Added 1987) (Amended 1993)

- (d) When a screen saver, power saver, or text is displayed prior to the beginning of a weighing operation both the operator and customer indicators shall display the numerical zero[s] condition when performing an actual weighing operation.*
Retroactive January 1, 2023
Amended 2021

(Amended 1987)

Previous Action:

- N/A

Original Justification:

Language was added to S.1.1 subpart c in 1987 and 1993. The language does not appear to allow for a non-digital sign, zero, to appear on the scale and does not appear to explicitly allow for something other than the zero to appear on the digital scale display, screen saver or power saver notwithstanding. If it does so allow a screen saver or power saver to eliminate a digital zero then the language appears to be in conflict with the General Code G-S.5 Indicating and Recording Elements.

Discussion language in the 1987 S&T Annual Report elaborated this issue but only as it relates to the scale user side with the condition[s] where a zero must appear. It does not discuss the consumer side of the digital scale and the right of the consumer to know the scale is at zero at the beginning of the transaction.

Without the zero being present on the display the consumer and merchant does not know if the scale is out of balance and not working properly.

S&T Item 7 Automated Checkout Stands of the 1973 S&T Committee's Final Report included the following:

“The philosophy expressed in this requirement is that the indications of weighing and measuring devices are readily and easily understood by all those affected. The key words in this paragraph are “clear,” “definite,” and “easily read.” Consequently, the equipment must be so designed that the indications and printed representations must meet these criteria for the owner or operator of the equipment and the customer. The decision regarding the amount of time necessary for weight values to be displayed to the customer is based on this requirement. That is, the values displayed must be clear, definite, and easily read. They must be displayed long enough for the information to be fully comprehended by the customer. Paragraph G-S.5.1. requires primary indications and recorded representations to be clear, definite, accurate, and easily read under any conditions of normal operation of the device.”

A condition of normal operation of some scales is when they automatically enter into a screen-saver mode. Yet, when a scale goes into a screen-saver mode, it causes the elimination of the scale's primary indications. If by going into a screen-saver mode the weight display is eliminated (even temporarily), primary indications can no longer be read. This condition conflicts with what is required by paragraph G-S.5.1., which specifies primary indications shall be easily read under any condition of normal operation of a device.



Screen-Saver Mode: No Primary Indications



Primary Indications

Without the zero being present on the display at the start of the transaction the potential for the facilitation of fraud is increased. The scale could be starting at higher or less than zero when the item is placed on it resulting in an overcharge or undercharge whether accidental or intentional. HB 44 language is intended to protect both the buyer and seller of commodities.

It would also be helpful to know the useful life of the consumer display both with the use of a screen saver versus without the use of a screen saver.

Changes to the physical scales would not be required as they already have this capability. Any changes are to software. With improvements to hardware and software capabilities and technologies having greatly improved since this section of the scale code was last amended.

The retroactive effective date would be January 1, 2023 giving retailers sufficient time to modify their screensaver software.

Merchants may argue that the requirement to include the display of the primary indications along with screen savers, power savers or text would require massive, complex, and expensive modifications to already existing software. However, computer programming technology has greatly improved since the 1973, 1987, and 1993 language was adopted in the Scale Code. Such modifications are much easier and less complex today. The end result further assures "Equity in the Marketplace."

The submitter requested voting status for this item in 2021.

Comments in Favor:

Regulatory:

- It had been observed in some cases where the weighing operation began however there was an error in the weightment likely attributed to the scale not starting on a zero-balance.
- If this feature is allowed to stand such as the display of a "split-screen" showing the screen saver and a digital zero display. Mr. Walsh and Mr. Cassidy agreed and stated they would be satisfied with a Developing status and would like to continue the development of this proposal,

Industry:

-

Advisory:

-

Comments Against:

Regulatory:

- The proper function of this feature would be verified by NTEP and therefore, there is adequate protection against incorrect weighments due to not starting on zero.
- Agrees with the Advisory comments below that precautions are in place and this item should be withdrawn.

Industry:

-

Advisory:

- In 1993 Scales Code requirement S.1.1. was amended to allow scale displays to present other than a digital zero display (e.g., screen savers, store advertisements/special buys). This alternative type of display would only be permitted when the scale is on a zero-balance condition and any weighing operations would not be allowed to take place unless the scale was in a zero-balance condition. With these precautions in place, there seems to be no risk that a weighing operation would be in error due to that operation not starting on zero.

Neutral Comments:

Regulatory:

-

Industry:

-

Advisory:

-

Item Development:

The Committee concluded that the current requirement provides enough security to prevent fraudulent use and therefore recommends this item be withdrawn.

Regional Associations' Comments:

WWMA 2020 Annual Meeting: Steven Harrington (Oregon) commented to look at the retroactive date and give plenty of time for adjustments/modifications. John Barton (NIST-OWM) John commented that there is a 1993 amendment to an existing requirement in place that allows for display other than zero and it would not be allowed to display other than zero if it was not on zero. That requirement requires an interlock that would not allow any weighments to take place unless a zero balance exists. Eric Golden (Cardinal Scale) Echoes Johns comments and stated it would not be that hard to accomplish. However, there may be a cost for the operators of such devices. Russel Vires (Mettler Toledo) commented that NTEP scales are tested for the functionality described by NIST. Additionally, he concurs with Steven Harrington and feels a 2027 retroactive date would be appropriate.

The Committee agrees that this item does not have merit and should be Withdrawn.

SWMA 2002 Annual Meeting: During Open Hearings, the Committee heard from John Barton (OWM) who stated that the handbook was amended in 1993 to permit systems to have screensavers, advertisements, or other alternate displays once a zero balance had been achieved. The Committee also heard from Ken Ramsburg (Maryland) who stated that this issue was already covered by the NTEP evaluation process.

After consideration of this item the Committee recommends that it be Withdrawn.

NEWMA 2020 Interim Meeting: Testimony was heard from the submitter and others that there are situations where scales have not returned to zero indication when weighing from a displayed screensaver or out-of-balance-condition. Arguments were made that meeting S.1.1. (c) would resolve this problem and that it may be an enforcement issue and not a code issue. Industry commented that the retroactive date of 2023 may not allow for the appropriate time to make the necessary software changes for an alternative like a split screen. The Committee believes this proposal has the potential to add information and clarity to the Handbook but should be investigated to ensure that current problem situations are not in violation of the Handbook as written. The item was discussed as a potential voting item with the following language edit to include a split screen display.

- (d) **When a screen saver, power saver, or text is displayed prior to the beginning of a weighing operation both the operator and customer indicators shall display a split screen showing the numerical zero(s) condition when performing an actual weighing operation.**
Retroactive January 1, 2024
Amended 2021

NEWMA recommends this be a Developing Item.

CWMA 2020 Interim Meeting: The S&T Committee received comments from both regulatory officials and industry representatives that this item is not a needed addition to the handbook and recommended this item be Withdrawn. We agree with the comments received, and recommend this item be Withdrawn.

Additional letters, presentation and data may have been submitted for consideration with this item. Please refer to <https://www.ncwm.com/publication-16> to review these documents.

| |
|--|
| CWMA Report |
| Comments and justification for the regional recommendation to NCWM: <i>(This will appear in NCWM reports)</i> |
| No comments on withdrawn items. |

SCL-20.9 D S.1.1.3. Zero Indication, Load Receiving Elements Separate from Weighing Elements, and Appendix D – Definitions: no load reference value

Note: This item was carried over from the 2020 Interim Meeting however, it was not a Voting item and therefore not discussed during the continuation of the 2020 Annual Meeting. Instead, the item was placed on the 2021 Interim Meeting’s agenda and was discussed during that meeting.

Source:
 Kansas Department of Agriculture

Purpose:
 Facilitate more accurate net weight determinations for systems utilizing a load-receiving element separate from a weighing element.

Item Under Consideration:
 Amend NIST Handbook 44, Scales Code as follows:

S.1.1.3. Zero Indication, Load-Receiving Elements Separate from Weighing Elements. – Provisions shall be made to indicate and record a no-load reference value and, if the no-load reference value is a zero-value indication, to indicate and record an out-of-balance condition on both sides of zero.
(Nonretroactive as of January 1st, 20XX)

S.1.1.3.1. Weighing Sequence. – **For weighing systems used to receive (weigh in), the no-load reference value shall be determined and recorded only at the beginning of each weighing cycle. For systems used to deliver (weigh out), the no-load reference value shall be determined and recorded only after the gross load reference value for each weighing cycle has been indicated and recorded.**

(Nonretroactive as of January 1st, 20XX)

S.1.1.3.2. Recording Sequence. – **Provision shall be made so that all weight values are indicated until the completion of the recording of the indicated value.**

(Nonretroactive as of January 1st, 20XX)

S.1.1.3.3 Zero-Load Adjustment. – **The weighing system shall be equipped with manual or semiautomatic means by which the zero-load balance or no-load reference value indication may be adjusted. Automatic zero-tracking and automatic zero-setting mechanisms are prohibited.**

(Nonretroactive as of January 1st, 20XX)

And amend Appendix D – Definitions as follows:

no-load reference value. – A positive **or negative** weight value indication with no load in the load-receiving element of a scale. ~~(Used with automatic bulk weighing systems and certain single draft, manually operated receiving hopper scales installed below grade and used to receive grain.)~~ [2.20, 2.22]

Background/Discussion:

This item has been assigned to the submitter for further development. For more information or to provide comment, please contact:

Mr. Doug Musick
Kansas Department of Agriculture
785-564-6681, doug.musick@ks.gov

There are many devices currently in use that, when not returned to zero, produce an inaccurate weighing. For example, a hopper scale used to weigh aluminum cans. The hoppers of these scales tend to become very sticky from residue and cans may stick to the side. When the indicator does not return to zero the operator will typically re-zero the scale to begin the next weighing. If the operator does not notice the device didn't return to zero, they may pay for the same cans more than once. If the device is re-zeroed with the can still stuck and it is knocked loose later, the customer may be paid for less material than they brought to the facility if the operator does not notice the indicator is below zero. If properly operated, a system utilizing a load-receiving element separate from a weighing element can be used to determine an accurate net weight.

In some cases, the load receiving element of a scale will retain materials (in the case of a hopper scale often referred to as the "heel"). This is typically a positive value but if the operator manually re-zero's the indicator and the material is subsequently cleared this can result in a negative value and should be accounted for when determining a net weight.

2020 NCWM Interim Meeting: The submitter stated the intent of this item was directed towards weighing systems utilizing hoppers and tanks and that his understanding of the NIST OWM analysis is that the intent of the proposal may not have been clear and will work towards clarifying the purpose of the item. He requested the committee assign a Developing Status. A representative of the NIST OWM indicated he had discussed the item with the submitter and is willing to work with him to assist in the development of the item.

A representative of the SMA commented that their group is opposed to the item because the intent is not understood.

During the Committee's work session, the committee assigned this item a Developing status.

2020 NCWM Annual Meeting: Due to the 2020 Covid-19 pandemic, this meeting was adjourned to January 2021, at which time it was held as a virtual meeting. Due to constraint of time, only those items designated as 2020 Voting Items were addressed. All other items were addressed in the subsequent 2021 NCWM Interim Meeting.

2021 NCWM Interim Meeting: The Committee heard testimony in the open hearing session from Mr. Loren Minnich (Kansas, submitter) stating that this proposal would replace another proposal from this submitter (ABW-16.1) which the submitter is recommending Withdraw. Mr. Minnich recommended an Information or Developing status for this item. Mr. Russ Vires (SMA) stated that the SMA takes no position on this item. Mr. Kevin Schnepf (California Division of Measurement Standards) supports a Developing status for the item.

During the 2021 Interim Meeting work session, the Committee recommended the submitter continue to work with NIST OWM to further develop this item and agreed the item should remain as a Developing status.

Regional Association Comments:

WWMA 2019 Annual Meeting: The Committee recognizes this as a new proposal and that there were no comments heard on the item during the open hearings. Due to the lack of comments regarding this proposal, the Committee does not offer any recommendation for its status.

SWMA 2019 Annual Meeting: The Committee has decided to make no recommendation on this item.

NEWMA 2019 Interim Meeting: The Committee and the body take no position on this item as no comments were heard during open hearings.

2020 Regional Meetings of the WWMA, NEWMA, and SWMA: These regions adhered to a condensed agenda due to the Covid pandemic and did not consider this item.

2020 CWMA Annual Meeting: The CWMA S&T Committee heard from the developer of this item, who requested this item remain developing to allow more time for input from all parties. The CWMA agreed and recommended this item remain as a Developing item.

Additional letters, presentations and data may have been part of the Committee’s consideration. Please refer to <https://www.ncwm.com/publication-16> to review these documents.

| CWMA Report |
|---|
| Comments and justification for the regional recommendation to NCWM: <i>(This will appear in NCWM reports)</i> |
| Loren Minnich, KS continues to work with NIST on this item and noted that limited work has been completed since January. Work will continue prior to the annual. If any question or suggestion can send to Loren. Russ Vires, SMA opposes this item as it may be an application issue and not a specification issue. Some members of SMA willing to participate in further development of this item. John Barton (NIST OWM) believes this item needs additional work and willing to work with Loren. The CWMA S&T Committee recommends that this item remain a developing item. |

SCL-20.12 V Sections Throughout the Code to Include Provisions for Commercial Single Draft Weigh-in-Motion Vehicle Scales.

Note: While this item was carried over from the 2020 Interim Meeting, it was not a voting item and therefore not discussed during the continuation of the 2020 Annual Meeting. Instead, it was placed on the 2021 Interim Meeting’s agenda and was discussed during that meeting.

Source:

Mettler-Toledo, LLC

Purpose:

Recognize commercial single draft Weigh-in-Motion vehicle scale systems.

Item Under Consideration:

Amend Handbook 44, Scales Code as follows:

S.1. Design of Indicating and Recording Elements and of Recorded Representations.

...

S.1.14. Weigh-in-Motion (WIM) Vehicle Scales

S.1.14.1. Identification of a Fault. – Fault conditions shall be presented to the customer and the operator in a clear and unambiguous manner. No weight value shall be indicated or recorded when a fault condition is detected. The following fault conditions shall be identified if applicable:

- (a) Vehicle speed was below the minimum or above the maximum speed as specified by the manufacturer.
- (b) A change in vehicle speed greater than that specified by the manufacturer was detected.
- (c) Vehicle direction of travel was not valid for the installation.
- (d) The amount of time all vehicle axles were simultaneously on the scale was below the minimum Data Acquisition Time.
- (e) Vehicle’s path of travel was outside the lateral side edges of the load-receiving element.

S.1.14.2 Information to be Recorded. – In addition to the information that is normally recorded for vehicle scales, the following shall also be printed and/or stored electronically for each vehicle weighment if applicable:

- (a) Scale identification if more than one lane at the site has the ability to weigh a vehicle in motion.
- (b) Vehicle direction of travel if the Weigh-in-Motion Vehicle Scale is bi-directional.

(Added 20XX)

...

S.3. Design of Load-Receiving Element

...

S.3.4. Length of Weigh-In-Motion Vehicle Scales – The load-receiving element shall be of sufficient length to allow the weighment of any vehicle intended to be weighed on the scale in a single draft (i.e. all axles of the vehicle are on the load-receiving element simultaneously during the weighment).

(Added 20XX)

...

S.6. Marking Requirements

| Table S.6.3.a. Marking Requirements | | | | | |
|--|---|--|--|------------------------|--------------------------------|
| To Be Marked With ↓ | Weighing Equipment | | | | |
| | Weighing, Load-Receiving, and Indicating Element in Same Housing or Covered on the Same CC ¹ | Indicating Element not Permanently Attached to Weighing and Load-Receiving Element or Covered by a Separate CC | Weighing and Load-Receiving Element Not Permanently Attached to Indicating Element or Covered by a Separate CC | Load Cell with CC (11) | Other Equipment or Device (10) |
| | | | | | |

| Table S.6.3.a. Marking Requirements | | | | | |
|--|---|-------|--------|---|--------|
| Manufacturer's ID (1) | X | X | X | X | X |
| Model Designation and Prefix (1) | X | X | X | X | X |
| Serial Number and Prefix (2) | X | X | X | X | X (16) |
| Certificate of Conformance Number (CC) (23) | X | X | X | X | X (23) |
| Accuracy Class (17) | X | X (8) | X (19) | X | |
| Nominal Capacity (3)(18)(20) | X | X | X | | |
| Value of Scale Division, "d" (3) | X | X | | | |
| Value of "e" (4) | X | X | | | |
| Temperature Limits (5) | X | X | X | X | |
| Concentrated Load Capacity (CLC) (12)(20)(22) | | X | X (9) | | |
| Special Application (13) | X | X | X | | |
| Maximum Number of Scale Divisions (n_{max}) (6) | | X (8) | X (19) | X | |
| Minimum Verification Scale Division (c_{min}) | | | X (19) | | |
| "S" or "M" (7) | | | | X | |
| Direction of Loading (15) | | | | X | |
| Minimum Dead Load | | | | X | |
| Maximum Capacity | | | | X | |
| Minimum and Maximum Speed (25) | | | X | | |
| Maximum Speed Change (26) | | | X | | |
| Vehicle Direction Restriction (27) | | | X | | |
| Safe Load Limit | | | | X | |
| Load Cell Verification Interval (v_{min}) (21) | | | | X | |
| Section Capacity and Prefix (14)(20)(22)(24) | | X | X | | |

(Added 1990) (Amended 1992, 1999, 2000, 2001, 2002, 2004 and 20XX)

| Table S.6.3.b. Notes for Table S.6.3.a. Marking Requirements | |
|--|--|
| <u>25. Weigh-in-Motion Vehicle Scales must be marked with minimum and maximum vehicle speed limitations. (Added 20XX)</u> | |
| <u>26. Weigh-in-Motion Vehicle Scales must be marked with maximum vehicle speed change allowed during the weighment. (Added 20XX)</u> | |

**Table S.6.3.a.
Marking Requirements**

**27. Weigh-in-Motion Vehicle Scales must be marked as uni-directional if the travel direction is restricted.
(Added 20XX)**

...

N.1. Test Procedures.

...

N.7. Weigh-in-Motion Vehicle Scale.

N.7.1. Reference Scale – A static scale as approved by the local jurisdiction shall be used to establish the weight of Reference Vehicles used in this procedure.

N.7.1.1. Dimension - The Reference Scale shall be of such dimension and spacing as to weigh Reference Vehicles in a single draft.

N.7.1.2. Location - The Reference Scale should be located near the Weigh-in-Motion Vehicle Scale to minimize the effect of vehicle fuel consumption. The Reference Scale and the Weigh-in-Motion Vehicle Scale may be the same scale.

N.7.1.3. Timing - The Reference Scale shall be tested immediately prior to using it to establish Reference Vehicle weights. A subsequent test of the Reference Scale may be performed immediately following the establishment of the Reference Vehicle weights to ensure its repeatability.

N.7.1.4. Qualification - The Reference Scale shall comply with the principles in the Fundamental Considerations paragraph 3.2. Tolerances for Standards.

N.7.2. Reference Vehicle – One or more Reference Vehicles shall be used to provide varying weight conditions for testing. Reference Vehicles should be representative of vehicles that are customarily weighed on the Weigh-in-Motion Vehicle Scale during normal operation. A motorized Field Standard Weight Cart with test weights and a driver may be used as an additional Reference Vehicle.

N.7.2.1. Weight Conditions - Reference Vehicle(s) shall be selected to provide at least a high and low weight condition. Different vehicle types may be used.

N.7.2.2. Load Position - Loads on the Reference Vehicle should be positioned equally side-to-side.

N.7.2.3. Static Weight - Reference Vehicle(s) shall be statically weighed on a Reference Scale as defined in N.7.1. immediately before being used to conduct the Weigh-in-Motion Vehicle Scale tests.

N.7.2.3.1. Rounding - Error weights may be added to the Reference Vehicle to increase its weight to a whole scale division to minimize rounding errors.

N.7.2.3.2. Re-weighing - Reference Vehicles may be re-weighed at the discretion of the testing authority.

N.7.3. Test speeds – The speed of the Reference Vehicle shall be maintained within the parameters as specified by the manufacturer during each test (see also S.1.14.1.a and S.1.14.1.b).

N.7.3.1 Range - Various speeds of the Reference Vehicle shall be used between the minimum and maximum operating speed specified for the Weigh-in-Motion Vehicle Scale. The minimum speed capability of the Reference Vehicle may be used as the minimum speed.

N.7.4. Static Tests for Weigh-in-Motion Vehicle Scale – The Weigh-in-Motion Vehicle Scale shall comply with applicable vehicle scale tests defined in N.1. when tested statically.

N.7.5 Dynamic Tests for Weigh-in-Motion Vehicle Scale – Test procedures shall simulate the normal intended use as closely as possible (i.e. test as used).

N.7.5.1. Vehicles - The tests shall be performed using the Reference Vehicle(s) defined in N.7.2.

N.7.5.2. Weighments - Each Reference Vehicle shall have a minimum of 5 weighments at the speeds as defined in N.7.3.

N.7.5.3. Vehicle Position - Reference Vehicle(s) must stay within the defined roadway along the load receiving element (see also S.1.14.1e).

N.7.5.4. Travel Directions - The tests shall be performed in both directions of travel unless travel direction is restricted by the marking.

N.7.5.5. Results - At the conclusion of the weigh-in-motion tests, there shall be a minimum of 10 total weight readings for the Reference Vehicle(s) for each applicable direction of travel. The tolerance for each weight reading shall be based on the gross vehicle weight and the applicable tolerance values for Class III L.

(Added 20XX)

...

| Table 7a. Typical Class or Type of Device for Weighing Applications | |
|---|--|
| Class | Weighing Application or Scale Type |
| I | Precision laboratory weighing |
| II | Laboratory weighing, precious metals and gem weighing, grain test scales |
| III | All commercial weighing not otherwise specified, grain test scales, retail precious metals and semi-precious gem weighing, grain-hopper scales, animal scales, postal scales, vehicle on-board weighing systems with a capacity less than or equal to 30 000 lb, and scales used to determine laundry charges |
| III L | Vehicle scales <u>(including weigh-in-motion vehicle scales)</u>, vehicle on-board weighing systems with a capacity greater than 30 000 lb, axle-load scales, livestock scales, railway track scales, crane scales, and hopper (other than grain hopper) scales |
| IIII | Wheel-load weighers and portable axle-load weighers used for highway weight enforcement |
| Note: A scale with a higher accuracy class than that specified as “typical” may be used. | |

(Amended 1985, 1986, 1987, 1988, 1992, 1995, ~~and 2012~~, and 20XX)

...

UR.3. User Requirements.

...

UR.3.13. Fault Indications for Weigh-In-Motion Vehicle Scales. – The fault conditions defined in S.1.14.1. shall be presented to the customer and the operator in a clear and unambiguous manner.
(Added 20XX)

...

Appendix D. Definitions

...

data acquisition time (DAT). – The total time an object is completely on a load-receiving element while it is being weighed in motion. An object is completely on a load-receiving element from the time the trailing edge of an object to be weighed first moves onto the load-receiving element up to the time the leading edge of the object first moves off the load-receiving element. This time duration is affected by the length of the load-receiving element, speed of the object to be weighed, and the length of the object to be weighed. [2.20]

(Added 20XX)

...

reference vehicle. – A vehicle with an associated load, including the driver, that has been statically weighed for temporary use as a field standard, typically the time required to test one Weigh-in-Motion Vehicle Scale. [2.20]

(Added 20XX)

...

vehicle scale. – A scale (including weigh-in-motion vehicle scales) adapted to weighing highway, farm, or other large industrial vehicles (except railroad freight cars), loaded or unloaded. [2.20]

(Amended 20XX)

...

weigh-in-motion (WIM) vehicle scale. – A vehicle scale adapted to weighing vehicles as they travel across the scale without stopping. [2.20] (Added 20XX)

Background/Discussion:

This item has been assigned to the submitter for further development. For more information or to provide comment, please contact:

Mr. Eric Wechselberger
Mettler-Toledo, LLC
614-202-7254, eric.wechselberger@mt.com

There has been a lot of work done to include Commercial Weigh-in-Motion into Handbook 44 over the past few years. Mettler-Toledo has been a supporter of adding WIM code into HB44, however, the axle weighing scale proposed has failed to demonstrate that it can meet the requirements and tolerances associated with commercial vehicle weighing.

There is a growing need in the market to provide commercial vehicle weighing transactions faster than can currently be done by static weighing. We also know weigh-in-motion vehicle scales can provide these faster transactions and meet the requirements to provide commercially accurate results dynamically when the complete vehicle is on the scale. For these reasons, Mettler-Toledo is submitting this proposal to amend Handbook 44 to include single draft WIM vehicle scales.

Those in favor of axle weighing scales may be opposed to WIM scales being included in UR.3.3. Single-Draft Vehicle Weighing. However, until those devices can demonstrate they can meet the Handbook 44 Class IIIIL requirements and provide adequate test procedures to verify the device can perform under all conditions of anticipated use, they should not be permitted to be used as commercial devices. Mettler-Toledo can demonstrate a single draft WIM vehicle scale can meet the HB44 requirements and we will work with the conference to refine the test procedures as needed in our proposal.

2020 NCWM Interim Meeting: The Committee was given a presentation on this proposal by the submitter, Mettler-Toledo, LLC. The presentation consisted of a video showing testing done on the submitter's WIM system using three different configurations of highway freight trucks. Comments from Mr. Tim Chesser (Arkansas), Mr. Doug Musick (Kansas) and Mr. Steve Harrington (Oregon) pointed out this system should include alerts to the operator that any parameters to be followed during weighments on this system were not followed. These parameters could include vehicle speed, slowing and/or acceleration of the vehicle while being weighed, proper tracking of the vehicle's wheels on the load-receiving element, etc. The comments included that if the parameters were exceeded by a significant amount, there should be no weight value indicated or recorded by the system.

Several Committee members asked the submitter to explain the terms "single-draft" and "multi-draft" weighing and how this system will determine when the entire weight of the vehicle is captured. Mr. Eric Wechselberger (Mettler-Toledo) explained that in general, multi-draft weighing is done by weighing independently the axles or groups of axles of the vehicle and mathematically summing those values. Single-draft weighing is performed when the entire vehicle is positioned on the load-receiving element. Mr. Wechselberger further explained their system will sense when the entire vehicle is positioned on the load-receiving element when the increase of weight value ceases and prior to the instant when the weight registered begins to decrease as the vehicle exits the load-receiving element.

The submitter also explained that these systems are subject to requirements addressing the approaches to the weighing element as found in HB 44 Scales Code UR.2.6. as well as adhering to the requirement addressing "single-draft weighing" in UR.3.3. Additionally, explanation was given regarding how Mettler Toledo's WIM system determines the speed of the vehicle as it travels across the load-receiving element.

Mr. Chesser as co-chair of the NCWM WIM TG, noted that the task group is struggling to come to consensus on appropriate test procedures for the WIM system addressed under SCL-16.1 and indicated that this proposal may benefit from the work the TG has done to this point. Mr. Chesser noted that the Committee may elect to add the further development of this item to the already formed TG. Mr. Eric Golden (Cardinal Scale) noted that it may be relatively easy to achieve acceptable results when using a particular type/configuration of vehicle as the test load, but it would be a bigger challenge to get the same results when

using a variety of different vehicle configurations. As the submitter, Mettler Toledo invited interested parties from NCWM to witness a series of demonstration tests to be conducted at their facility on March 10, 2020. Mr. Golden also raised the question if multi-platform vehicle scales are considered to provide a weighment that is multi-draft and can these types of vehicle scales be used as WIM scales.

Mr. Brad Fryburger (Rinstrum) as submitter of SCL-16.1 asked the Committee what results are necessary in terms of accuracy to provide evidence that these types of WIM systems are viable and would provide justification for a proposal such as this to move forward. He further explained that Rinstrum's system (which uses multi-drafts of axles or axle groups to calculate a total gross weight of the vehicle) has yet to demonstrate a 100 % compliance with the HB 44 Scales Code Class III L tolerances. Mr. Fryburger was of the understanding that a WIM system used for weighing highway vehicles was required to prove its capability of providing accurate weighments 100 % of the time.

NIST OWM commented that it was not their belief that these systems be within Class III L tolerances for each and every weighment to demonstrate the proposed changes have merit and to justify that work continue by the TG assigned to SCL-16.1. If and when these systems are type approved and placed in service, field testing will confirm they are suitable for use and the marketplace will determine their viability for commerce. Additionally, OWM noted the proposal recommends the addition of requirement S.1.8.6. (addressing values to be recorded) and that the proposed location in the Scales Code may be inappropriate. OWM points out that this requirement is not directed towards computing scales and would be located more appropriately elsewhere in the HB 44 Scales Code.

Mr. Constantine Cotsoradis (Flint Hills Resources) and Mr. Wechselberger recommended the Committee assign a Voting status to this item.

During the Committee's work session, it was decided the item does have merit and that it should be given a Developing status. The Committee will provide the submitter specific detail on what additional information is needed to move the item forward with a recommendation that the submitter carefully review NIST OWM's analysis of the proposal and comments heard during the open hearing session.

2020 NCWM Annual Meeting: Due to the 2020 Covid-19 pandemic, this meeting was adjourned to January 2021, at which time it was held as a virtual meeting. Due to constraint of time, only those items designated as 2020 Voting Items were addressed. All other items were addressed in the subsequent 2021 NCWM Interim Meeting

2021 NCWM Interim Meeting: The Committee acknowledged that the item under consideration was not the most recent iteration which the submitter wanted to be presented to the NCWM. The submitter (Mr. Eric Wechselberger – Mettler Toledo) provided a presentation to the members in the open hearing session regarding the performance of their system.

Mr. Loren Minnich (Kansas), Mr. Alan Walker (Florida), Mr. Eric Golden (Cardinal Detecto Scales) and Mr. Kevin Schnepf (CA Division of Measurement Standards) all stated their support for the item. Mr. Russ Vires (SMA), Mr. Jan Konijnenburg (Rice Lake Weighing Systems), and Mr. Ken Ramsburg (Maryland) supported a voting status for this proposal.

Mr. John Barton (NIST OWM) explained that this item was developed however, OWM would recommend that test procedures for any reference scale to be used during an official examination be included in the proposal. NIST OWM has been concerned that a number of dynamic weighing systems are lacking this important detail and would like to establish a practice where these test procedures are documented in detail. Mr. Charlie Stutesman (Kansas) believes this should not be held back in order to establish test procedures for a reference scale.

During the 2021 Interim Meeting committee's work session, the Committee concluded that the item is fully developed and should be presented for a vote although the most recent iteration may not have been given sufficient time for review.

Regional Association Comments:

WWMA 2019 Annual Meeting: Mr. Russ Vires (Mettler-Toledo) commented as the submitter of the item that input is requested from the regional associations, regulators, and other sources on the changes being proposed. Mr. Vires stated that he believes the item is fully developed and requested that it be assigned as a Voting item. Mr. John Barton (NIST) stated that OWM has not had enough opportunity to review this item fully but that it is encouraging to note that the submitter is offering others the opportunity to observe the submitter's device being tested to provide evidence that it will meet Class III L tolerances. Mr. Eric Golden (Cardinal Scale) stated that as a member he has experienced the frustration in the past 18 months with the existing WIM

TG addressing item SCL-16.1. Mr. Golden stated that Cardinal could support this proposal as a Developing item with some reservations.

The Committee agrees the item has merit and also that the item be given a Developing status. The Committee notes that the submitter has stated there is an opportunity for having members of the NCWM, NIST, and/or regulatory officials to witness the operation of the systems referenced in this proposal thus providing evidence the systems will meet current Class III tolerances.

SWMA 2019 Annual Meeting: Mr. Tim Chesser (Arkansas) recommended this item be given an Assigned status. Mr. Russ Vires (Mettler-Toledo) stated that he did not support an Assigned status and is willing to demonstrate the capabilities of the device by the 2020 NCWM Interim Meeting. He believes the item is well developed but would rather the item be recommended as Developing back to Mettler-Toledo, the submitter. Mr. Eric Golden (Cardinal Scale) asked how multi-platform scales would be considered moving forward, and that he supports single draft weighing. Mr. Dick Suiter (WIM Task Group) stated that this item conflicts with the task group’s proposal if single draft weighing became the only allowable method. He also stated that the task group wants to remove the single draft requirement for WIM Vehicle Scales.

The Committee recommends this item be Assigned to the WIM Task Group.

NEWMA 2019 Interim Meeting: The Committee and the body agree that this item has merit and should be given an assigned status. During open hearings, Mr. Dick Suiter (Richard Suiter Consulting) commented that as a WIM member, recommend the item be assigned. He explained that this proposal is different than SCL-16.1 because it proposes using a single draft with a full-length truck scale. Mr. John McGuire (New Jersey) and Mr. Jim Willis (New York) agree with this position

2020 Regional Meetings of the WWMA, NEWMA, and SWMA: These regions adhered to a condensed agenda due to the Covid pandemic and did not consider this item.

2020 CWMA Interim Meeting: Mr. Russell Vires (Mettler-Toledo, LLC) gave a presentation to the CWMA S&T committee on this item. The presenter answered a number of questions from the committee and from both regulatory officials and industry representatives on this item. A concern that was highlighted questioned if placing the reference scale into high resolution, the reference scale may not comply with the N max requirement. Another concern of regulatory officials was the need to test the reference scale to used capacity with known field standards. This could require an additional burden to both the regulatory officials and the device owners. Mr. Vires commented that this item was still being developed with the goal of presenting a final version at the NCWM meeting in January. Not having seen a final version of the item, the committee recommends this item remain a developing item.

Additional letters, presentations and data may have been part of the Committee’s consideration. Please refer to <https://www.ncwm.com/publication-16> to review these documents.

| |
|--|
| SCL-20.12 |
| Regional recommendation to NCWM on item status: |
| XX Recommend as a Voting Item on the NCWM agenda |
| Comments and justification for the regional recommendation to NCWM: <i>(This will appear in NCWM reports)</i> |

Russ Vires (Mettler-Toledo) Mettler Toledo has demonstrated the ability to accurately utilize weigh in motion technology. They have met with NIST, NTEP, and several regulators as well held several webinars on this item. They believe this proposal is complete and the item is ready to be voted on. They are willing to work with NIST OWM on test procedures when the item is adopted and ask for support to pass this in July 2021. Doug Musick (KS) noted that Mettler should be held as a good standard for companies that introduce new technology. Doug suggests some changes but states he will agree with the item as is going forward at the annual meeting. He provided some suggested changes from his review of the item and will forward to the S&T committee.

John Barton - NIST OWM these scales are dynamic it is more and more difficult to test the device using a reference standard to test the device rather than a known artifact. Creating a reference test standard that meets the principles of Appendix A Fundamental Considerations is a challenge that is not addressed in this proposal. OWM suggests that stakeholders get together to develop test procedures.

Eric Golden (Cardinal Scale) Cardinal supports this item going forward as a voting item in July. They support some changes to publication 14 on the testing side. They believe that the weigh in motion scale being tested should also be used as the static reference scale for the test. Russ Vires, (SMA). SMA recommends the adoption of this item. Russ Vires, (Mettler Toledo) stated the WIM scale must be a good static scale first. Charlie Stutesman (KS) asked if a different type of scale can be approved for this criteria like a CAT scale. Russ Vires stated that the entire truck must be on the load receiving element for this proposal. Charlie likes the proposal. Russ Vires stated these devices will be NTEP evaluated and Mettler Toledo technology requires that entire truck must be on the load receiving element. Eric Golden stated the code is already available for multi-platform scales.

The CWMA S&T Committee recommends that this item moves forward as a voting item.

ABW – AUTOMATIC BULK WEIGHING SYSTEMS

ABW-16.1 W A. Application, S Specifications, N. Notes, UR. User Requirements and Appendix D – Definitions: automatic bulk weighing system.

Source:
Kansas

Purpose:

Modernize the ABWS Code to more fully reflect the types of systems in use and technology available while still maintaining the safeguards of the current code and amend the ABWS definition by removing requirements that are included in specifications and providing guidance as to what amount of automation is required for an Automatic Bulk Weighing System.

Item Under Consideration:

Amend Handbook 44, Automatic Bulk Weighing Systems Code as follows:

A. Application

A.1. General. – This code applies to ~~automatic bulk~~ weighing systems, ~~that is, weighing systems capable of adapted to the automatic~~ automatically weighing ~~of a commodity in~~ successive drafts of a commodity without operator intervention. ~~predetermined amounts automatically recording the no load and loaded weight values and accumulating the net weight of each draft.~~

(Amended 1987 and 20XX)

S. Specifications

S.1. Design of Indicating and Recording Elements and Recorded Representations.

S.1.1. Zero Indication. – ~~Provisions An automatic bulk weighing system shall be made to~~ indicate and record a no-load reference value and, if the no-load reference value is a zero value indication, to indicate and record an out-of-balance condition on both sides of zero.

(Amended 20XX)

...

S.1.5. Recording Sequence. – ~~Provision~~An automatic bulk weighing system shall be made so that indicate all weight values ~~are indicated~~ until ~~the completion of the~~ recording of the indicated value is completed.
(Amended 20XX)

S.1.6. Provision for Sealing Adjustable Components on Electronic Devices. – Provision shall be made for applying a security seal in a manner that requires the security seal to be broken before an adjustment can be made to any component affecting the performance of the device.

S.1.7. No Load Reference Values – An automatic bulk weighing system shall indicate and record weight values with no load in the load-receiving element. No load reference values must be recorded at a point in time when there is no product flow into or out of the load receiving element. Systems may be designed to stop operating if a no load reference value falls outside of user designated parameters. If this feature is designed into the system then the no load reference value indicated when the system is stopped must be recorded, an alarm must activate, weighing must be inhibited, and some type of operator intervention must be required to restart the system after it is stopped.

(Added 20XX)

S.1.8. Loaded Weight Values – An automatic bulk weighing system shall indicate and record loaded weight values for each weighment.

(Added 20XX)

S.1.9. Net Weight Values – An automatic bulk weighing system shall calculate and record net weight for each weighment.

(Added 20XX)

S.1.10. Net Weight Accumulation – An automatic bulk weighing system shall accumulate and record the sum of all net weight values for all weighments performed during a weighing process.

(Added 20XX)

S.3. Interlocks and ~~Gate Control~~Product Flow Control.

S.3.1. ~~Gate Position~~Product Flow Control. – ~~Provision~~An automatic bulk weighing system shall be made to clearly indicate to the operator product flow status ~~the position of the gates leading directly~~ to and from the ~~weigh hopper~~ load receiving element. Many types of equipment can be used to control the flow of product into and out of a load receiving element automatically including but not limited to gates, conveyors, augers, robots, pipes, tubes, elevators, buckets, etc.

(Amended 20XX)

S.3.2. Interlocks. – Each automatic bulk weighing system shall have operating interlocks to provide for the following:

- (a) Product cannot be cycled and weighed if the weight recording element is disconnected or subjected to a power loss.
- (b) can only cannot print record a weight if either of the gates equipment controlling product flow to or from the load-receiving element is in a condition which prevents product entering or leaving the load receiving element, leading directly to or from the weigh hopper is open.
- (c) A “low paper” sensor, when provided, is activated.
- (d) The system will operate only in the proper sequence in all modes of operation.

- (e) When an overflow alarm is activated, the system shall indicate and record an overflow condition.
(Amended 1993 and 20XX)

S.3.3. Overflow Sensor And Interference Detection.

- (a) An automatic bulk weighing system must have a means to detect when The the weigh hopper load-receiving element shall be equipped with an is overfilled. When an overflow condition exists sensor which will cause the feed product flow to the load receiving element must be stopped, gate to close an alarm must activate, activate an alarm, and inhibit weighing must be inhibited until the overflow condition has been corrected, and some type of operator intervention must be required to restart the system. An alarm could be many things including a flashing light, siren, horn, flashing computer screen, etc. The intent of an alarm is to make the operator aware there is a problem which needs corrected.

(Added 1993) (Amended 20XX)

- (b) If the system is equipped with a Downstream storage devices and other equipment, permanent or temporary, lower garner or surge bin, that garner shall also which have the potential to interfere with weightment when overfilled or not functioning properly must have a means to prevent interference. When interference exist the system must stop, an alarm must activate, product flow must stop, weighing must be inhibited until the interference has been corrected, and some type of operator intervention is required to restart the system. -be equipped with an overflow sensor which will cause the gate of the weigh hopper to remain open, activate an alarm, and inhibit weighing until the overflow condition has been corrected.

[Nonretroactive as of January 1, 1998]

(Amended 1997 and 20XX)

N. Notes

N.1. Testing Procedures.

N.1.1. Test Weights. – The increasing load test shall be conducted using test weights equal to at least 10 % of the capacity of the system:

- (a) on automatic-~~grain~~ bulk-weighing systems installed after January 1, 1984 used to weigh grain; and
(b) on other automatic bulk-weighing systems installed after January 1, 1986.
(Amended 1987, and 20XX)

UR. User Requirements

UR.4. System Modification. – Components of-The the automatic bulk weighing system, shall not be modified except when the modification has been approved by a competent engineering authority, preferably that of the engineering department of the manufacturer of the scale, and the official with statutory authority having jurisdiction over the scale.

(Amended 1991 and 20XX)

And amend Handbook 44 Appendix D – Definitions as follows:

automatic bulk weighing system. – A weighing system capable of adapted to the automatic automatically weighing of ~~bulk commodities in~~ successive drafts of a commodity without operator intervention, predetermined amounts, automatically recording the no load and loaded weight values and accumulating the net weight of each draft. [2.22]

Background/Discussion:

This item has been returned to the submitter for further development. For more information or to provide comment, please contact:

Mr. Doug Musick
 Kansas Department of Agriculture
 785-564-6681, doug.musick@ks.gov

NOTE: The updated version provided in 2016 and 2017 is that which is shown in Item under Consideration for this item. To view previous versions of the proposal, refer to the committee's 2016 and 2017 Final Reports.

The following rationale was offered by the submitter of this item for proposing changes to the HB 44 ABWS Code:

- There are many systems in use that don't meet the definition for a "scale" or an "ABWS" or anything else in the Handbook. These changes will make it easier for regulators/inspectors to determine if a system should be evaluated as an "ABWS".
- The wording "automatic bulk weighing systems" should not be used in the definition of the same.
- The "no-load" and "loaded weight" recordings are important, but they are specifications and should not be included in the application code.
- The current code does not clearly define at what level of automation a system would be considered an ABWS versus a scale with some accessory equipment (hopper, tank, etc.). This is an attempt to more clearly distinguish which systems should be considered ABWSs.
- Human intervention could be many things. Some examples include, but are not limited to, pushing a reset button, turning power off then back on, typing a password, or entering a statement into a system log. The intent with including the term "human intervention" is to not include all systems which have a high degree of automation, only the ones that cycle repeatedly and can potentially operate without anyone present to observe weighing malfunctions.
- There are many types of load receiving elements that will work with an ABWS to include, but not limited to, tanks and hoppers so the previous language referring to hoppers was removed and replaced with the generic but accurate term "load receiving element".
- The old language implied separate sensors (e.g., bindicators) were required. Newer systems have already bypassed the use of separate sensors and utilize the weight indications to identify an overfilled condition, similar to how the indications are used to regulate product flow into the load receiving element for some devices. Concerns for this approach have been raised for situations when an indicator is not functioning properly. That is a legitimate concern, but my reply then is: What is the backup for an indicator not indicating properly on any other type of device? This is something we know happens with other devices and commonly may not be detected until a device inspection and test is completed. Thus, one reason routine inspections and testing are required.
- Many types of equipment can be used to control the flow of product into and out of a load receiving element automatically, including but not limited to gates, conveyors, augers, robots, pipes, tubes, elevators, and buckets. Examples would be a conveyer delivering product; in such a case, the recording element should not record if the conveyer is still moving, or in the case of a pneumatic transfer tub the recording element should not record if the blower forcing air through the tube is still operating. Therefore, the old language referring to gates was removed and replaced with more generic terminology which can be applied to any equipment used to control product flow, not just gates.
- Many types of equipment can be used for downstream commodity storage including but not limited to hoppers, tanks, bins, flat storage, trucks, totes, rail cars, and pits. The language referring to "lower garner", "surge bin," etc., has been removed and replaced with more descriptive terms such as "downstream storage devices" to allow for all potential types of product handling equipment.
- A downstream storage device itself may not interfere with the weighing process directly, but it also cannot create a situation in which an overflow condition or some other malfunction of the equipment interferes with the weighing process. An example would be a grain storage hopper located under a weigh hopper in a position which, when grain is mounded up above the storage hopper, the grain touches the bottom of the weigh hopper and interferes with the weighing process.

For this example, if the storage hopper can be lowered far enough below the weigh hopper so that the mounded grain cannot touch the weigh hopper when it reaches its' maximum potential height then it would not need the capability to detect an overflow condition. The same scenario would apply to a truck parked under the load receiving element or a conveyer under the load-receiving element. Wording was added to ensure interference does not occur and if it does that the system activates controls to prevent weighing errors.

The Committee received updates on this item by its submitter, Mr. Doug Musick (Kansas) at the NCWM Interim and Annual Meetings of 2016 and 2017. The Committee agreed at each these meetings to maintain the Developing status of the item to provide Mr. Musick the opportunity to fully develop the proposal.

2018 NCWM Interim Meeting: The Committee received comments from Mr. Musick, submitter of the item. Mr. Musick asked the Committee to keep the item in a Developing status as there are changes being made to the item based on comments and feedback received from recent regional meetings. During the Committee's work session, it was agreed to keep the item Developing as requested by the submitter.

2018 NCWM Annual Meeting: The Committee did not take comments during open hearings on Developing items at the Annual Meeting except to grant the submitter of a Developing item an opportunity to provide an update on the progress made to further develop the item(s) since the 2018 NCWM Interim Meeting. Mr. Loren Minnich (Kansas) gave an update on the Developing item to the Committee. Mr. Minnich stated that he or Mr. Musick plan on giving presentations at 2018 regional meetings to provide more detail on the item. Kansas hopes to have this item fully developed so it can be presented for vote next year.

OWM provided the following written recommendations and comments to this item as feedback to the submitter and as part of its analysis of the S&T Committee's 2018 agenda items:

- The changes proposed in ABW-3, ABW-4, and OTH-6 are all related attempts to help clarify and make it easier for field officials to determine the proper HB 44 code to apply to some newer automatic weighing systems that have been introduced into the commercial arena. OWM is unable to envision, based upon its review of these three proposals, how the proposals, whether considered individually, or combined and considered as a group, will accomplish this intended outcome. Addressing these issues in a piecemeal fashion may actually result in more confusion.
- With respect to this particular item, OWM reiterates its comments included in the analysis it provided to the Committee at the January 2018 Interim Meeting. The proposed changes to the Automatic Bulk Weighing Systems (ABWS) Code would expand its application to include some newer automatic weighing systems that currently fail to meet the application of the ABWS Code (or the current HB 44 definition of an ABWS). OWM is not convinced this is a technically sound appropriate approach.
- The current ABWS Code applies to systems that automatically weigh a single commodity in successive drafts; yet we believe it was the submitter's intent in drafting some of the proposed changes that the code also apply to systems that automatically weigh more than one commodity at a time in successive drafts. For example, some seed treatment systems can be programmed to weigh multiple drafts of the same recipe, which, oftentimes, is made up of different ingredients (commodities) that get mixed together to form the treatment for a particular seed type. The various recipes to be weighed by a system can include not only different ingredients, but also different amounts of those ingredients, both of which can affect the price charged to customers. Expanding the application of the ABWS Code to address such systems may cause unnecessary confusion. For this reason, OWM prefers maintaining the current ABWS Code as is. Perhaps a better approach to addressing these systems and the resulting gaps in HB 44 requirements would be to form a small group to further study such systems and recommend Handbook 44 changes, possibly including consideration of a separate code to address these and other types of dynamic weighing systems.

The Committee agreed to carryover this item on its 2019 agenda in a Developing status and looks forward to being able to consider a final completed version.

2019 NCWM Interim Meeting: Mr. Musick, submitter of the item, requested the Committee designate this item either "Developing" or "Informational" given the written comments the Committee received from CompuWeigh Company and NIST OWM in advance of the 2019 Interim Meeting. Mr. Musick reported he believes this item has merit. Automatic bulk weighing systems can provide greater accuracy in weighing bulk commodities that don't flow well when fed into or discharged from a hopper. The number of automatic weighing systems in the commercial marketplace is increasing and some of the more current

systems don't seem to fit the application section of any particular HB 44 code. This "newer" equipment needs to be addressed somewhere in HB 44. Designating this item as "developing" or "informational" will provide time needed to address the concerns noted in the comments provided by CompuWeigh Company and NIST OWM.

In written comments and recommendations provided to the Committee in advance of the 2019 NCWM Interim Meeting, NIST OWM provided the Committee the following points concerning this item:

- OWM views the changes proposed to paragraph A.1. as expanding the scope of the current Automatic Bulk Weighing Systems Code to encompass types of systems not previously considered an ABWS.
- While OWM agrees with the concept of updating the current code to pave the way for its application to newer automated weighing systems, OWM believes the current draft proposal is not sufficiently developed enough to be considered for adoption.
- Critical parts of the Handbook 44, Appendix D definition of "automatic bulk weighing system" and paragraph A.1. of the ABWS Code that are proposed for deletion provide the unique and distinguishing operational features of these systems and are therefore, very significant in identifying ABWS and are imperative for determining the application of the correct HB 44 code.
- "Loaded weight value" (paragraph S.1.8.), "weighing process" (paragraph S.10.), and "weighment" (paragraphs S.1.8., S.1.9., and S.1.10) in this proposal are ambiguous terms that need to be clearly defined.
- The changes proposed to paragraph S.3.3.(a) and (b) need additional work. For example, it is important to specify in (a) that product flow to the load-receiving element must automatically stop rather than be stopped. Also, the terminology "other equipment" needs better clarification in the first sentence proposed for sub-paragraph (b). Additional language is needed to clarify the proper application of these two subparagraphs.

To view all of OWM's comments and recommendations pertaining to this item, refer to OWM's analysis of the different items on the S&T Committee's agenda posted on the NCWM website for the 2019 NCWM Interim Meeting.

2019 NCWM Annual Meeting: The Committee was told by the submitter that there was no new information to update although, Mr. Loren Minnich would be working to further develop this item for the state of Kansas. The Committee agreed to maintain this proposal as a Developing Item.

2020 NCWM Interim Meeting: The submitter of the item acknowledged that there has been little progress on this item in the last few cycles and asked the Committee to retain the Developing status for the next cycle to allow more time to address the issue identified by various stakeholders. Mr. Russ Vires (SMA) commented that their group had no position on this item.

NIST OWM commented that the ABWS code was written for very specific types of devices and that these changes may broaden the scope of the code to include devices that the HB 44 ABWS Code was not intended to apply to. OWM also suggested that it may be more appropriate to amend the HB 44 Scales Code to apply to certain automated systems being addressed by the submitter of this item.

The Committee agreed to retain the Developing status of this item during the work session.

2020 NCWM Annual Meeting: Due to the 2020 Covid-19 pandemic, this meeting was adjourned to January 2021, at which time it was held as a virtual meeting. Due to constraint of time, only those items designated as 2020 Voting Items were addressed. All other items were addressed in the subsequent 2021 NCWM Interim Meeting

2021 NCWM Interim Meeting: The submitter, Mr. Minnich stated that this proposal is being replaced by another item on this agenda (SCL-20.9) that is being developed to serve the same purpose. Mr. Minnich recommends the Committee withdraw this item.

During the committee's work session, the Committee agreed with the submitter and chose to withdraw the item.

Regional Association Comments:

WWMA 2019 Annual Meeting: During the open hearing session, the Committee heard comments from Mr. Russ Vires (SMA) have no opinion at this time. Mr. John Barton (NIST OWM) stated that the submitter proposal to modify the ABWS Code by introducing terminology that reflects the newer technology in use today however, he believes that there is too much focus being given to “automation” and not enough focus on the unique and specific characteristics of ABWS devices. Also, by removing the description of ABWS from the Applications Section of the Code, this proposal will widen the scope to include systems not intended to be covered under the ABWS Code.

The Committee agreed to recommend this item be withdrawn. The Committee recognizes that there have been no changes to the proposal since the last cycle of hearings.

SWMA 2019 Annual Meeting: Mr. Russ Vires (SMA) stated SMA had no position on this item at this time. The Committee decided to make No Recommendation on this item.

NEWMA 2019 Interim Meeting: The Committee and the body agree with comments made in the Western Weights and Measures Association report that this item should be withdrawn as no changes or additional information has been provided since 2016. No comment was heard during open hearing.

2020 Regional Meetings of the WWMA, NEWMA, and SWMA: These regions adhered to a condensed agenda due to the Covid pandemic and did not consider this item.

CWMA 2020 Interim Meeting: Mr. Minnich the developer of the item gave an update to the item to the CWMA S&T Committee and requested the item remain developing to allow for more time to fully develop the item. We ask the NCWM S&T Chair to give the developer a deadline of one year to present substantial progress on this item or withdraw it.

Additional letters, presentations and data may have been part of the Committee’s consideration. Please refer to <https://www.ncwm.com/publication-16> to review these documents.

| CWMA Report |
|---|
| Comments and justification for the regional recommendation to NCWM: <i>(This will appear in NCWM reports)</i> |
| No comments on withdrawn items. |

BLOCK 4 ITEMS (B4) ELECTRONICALLY CAPTURED TICKETS OR RECEIPTS

Note: The item under consideration reflects changes that were received by the committee from the submitter of the item and that the Committee agreed to during its 2021 Interim Meeting work session. The changes are highlighted.

Source:

Kansas Department of Agriculture, Division of Weights and Measures

Purpose:

Allow recorded values to be captured electronically as an alternative to a printed ticket or receipt.

B4: GEN-21.2 D G-S.5.6. Recorded Representations.

Item Under Consideration:

Amend Handbook 44, General Code as follows:

G-S.5.6. Recorded Representations. – Insofar as they are appropriate, the requirements for indicating and recording elements shall also apply to recorded representations. All recorded values shall be **printed-provided presented** digitally. In applications where recorded representations are required **by a specific code**, the customer may be given the option of not receiving the recorded representation. **Unless otherwise specified, recorded representations referenced in specific codes**

shall be made available to the customer as a minimum in hard copy form. However, for systems equipped with the capability of issuing an electronic receipt, ticket, or other recorded representation, the customer may be given the option to receive any required information electronically (e.g., via cell phone, computer, etc.) in lieu of or in addition to a hard copy. (Amended 1975, 2014 and **20XX**)

B4: LMD-21.2 D S.1.6.5. Money Value Computations., UR.3. Use of a Device.

Item Under Consideration:

Amend Handbook 44, Liquid Measuring Devices Code as follows:

S.1.6.5. Money-Value Computations

...

S.1.6.5.6. Display of Quantity and Total Price, Aviation Refueling Applications.

- (a) *The quantity shall be displayed throughout the transaction.*
- (b) *The total price shall also be displayed under one of the following conditions:*
 - (1) The total price can appear on the face of the dispenser or through a controller adjacent to the device.
 - (2) If a device is designed to continuously compute and display the total price, then the total price shall be computed and displayed throughout the transaction for the quantity delivered.
- (c) *The total price and quantity shall be displayed for at least five minutes or until the next transaction is initiated by using controls on the device or other customer-activated controls.*
- (d) *A ~~printed~~ receipt shall be available and shall include, at a minimum, the total price, quantity, and unit price.*

[Nonretroactive as of January 1, 2008]

(Added 2007) (**Amended 20XX**)

S.1.6.7. Recorded Representations. – Except for fleet sales and other price contract sales and for transactions where a post-delivery discount is provided, a ~~printed~~ receipt providing the following information shall be available through a built-in or separate recording element for all transactions conducted with point-of-sale systems or devices activated by debit cards, credit cards, and/or cash:

- (a) *the total volume of the delivery;**
- (b) *the unit price;**
- (c) *the total computed price;**
- (d) *the product identity by name, symbol, abbreviation, or code number;* and*
- (e) *the dispenser designation by either an alphabetical or numerical description. ***

**[Nonretroactive as of January 1, 1986] **[Nonretroactive as of January 1, 2021]*

(Added 1985) (Amended 1997, 2012, 2014, 2018 and **20XX**)

S.1.6.8. Recorded Representations for Transactions Where a Post-Delivery Discount(s) is Provided. – Except for fleet sales and other price contract sales, a ~~printed~~ receipt providing the following information shall be available through a built-in or separate recording element that is part of the system for transactions involving a post-delivery discount:

- (a) the product identity by name, symbol, abbreviation, or code number;
- (b) transaction information as shown on the dispenser at the end of the delivery and prior to any post-delivery discount(s), including the:
 - (1) total volume of the delivery;
 - (2) unit price; and
 - (3) total computed price of the fuel sale.
- (c) an itemization of the post-delivery discounts to the unit price;
- (d) the final total price of the fuel sale after all post-delivery discounts are applied; and
- (e) *the dispenser designation by either an alphabetical or numerical description.*

[Nonretroactive as of January 1, 2021]

(Added 2012) (Amended 2014, ~~and 2018~~, and 20XX)

...

UR.3. Use of a Device

...

UR.3.3. Computing Device – Any computing device used in an application where a product or grade is offered for sale at one or more unit prices shall be used only for sales for which the device computes and displays the sales price for the selected transaction.

(Became retroactive 1999)

(Added 1989) (Amended 1992)

The following exceptions apply:

- (a) Fleet sales and other price contract sales are exempt from this requirement.
- (b) A truck stop dispenser used exclusively for refueling trucks is exempt from this requirement provided that:
 - (1) all purchases of fuel are accompanied by a ~~printed~~ receipt of the transaction containing the applicable price per gallon, the total gallons delivered, and the total price of the sale; and
(Added 1993)
 - (2) unless a dispenser complies with S.1.6.4.1. Display of Unit Price, the price posted on the dispenser and the price at which the dispenser is set to compute shall be the highest price for any transaction which may be conducted.
(Added 1993)
- (c) A dispenser used in an application where a price per unit discount is offered following the delivery is exempt from this requirement, provided the following conditions are satisfied:
 - (1) the unit price posted on the dispenser and the unit price at which the dispenser is set to compute prior to the application of any discount shall be the highest unit price for any transaction;

(Amended 2014)

- (2) all purchases of fuel are accompanied by a receipt recorded by the system. The receipt shall contain:
- a. the product identity by name, symbol, abbreviation, or code number;
 - b. transaction information as shown on the dispenser at the end of the delivery and prior to any post-delivery discount including the:
 - 1. total volume of the delivery;
 - 2. unit price; and
 - 3. total computed price of the fuel sale prior to post-delivery discounts being applied.
 - c. an itemization of the post-delivery discounts to the unit price; and
 - d. the final total price of the fuel sale.

(Added 2012) (Amended 2014)

(Added 1989) (Amended 1992, 1993, 2012, ~~and 2014, and 20XX~~)

UR.3.4. Printed Ticket. Recorded Representation – The total price; the total volume of the delivery; the price per liter or gallon; *and a corresponding alpha or numeric dispenser designation** shall be ~~shown, either printed~~ **recorded** by the device ~~or in clear hand script~~, on any ~~printed ticket issued by a device and~~ **recorded representation** containing any one of these values **and shall comply with G-S.5.6**. Establishments where no product grades are repeated are exempt from the dispenser designation requirement.

**[Nonretroactive as of January 1, 2021]*

(Amended 2001, 2018, ~~and 2019, and 20XX~~)

B4: VTM-21.1 D S.1.1. Primary Elements., UR.2. User Requirements

Item Under Consideration:

Amend Handbook 44, Vehicle Tank Meter Code as follows:

S.1.1. Primary Element

S.1.1.1. General. – A meter shall be equipped with a primary indicating **element. and may also be equipped with a primary recording element. Except for systems used solely for the sale of aviation fuel into aircraft and for aircraft-related operations, a meter shall be equipped with a primary recording element.**

(Amended 1993 ~~and 20XX~~)

~~**Note:** Except for systems used solely for the sale of aviation fuel into aircraft and for aircraft related operations, vehicle tank meters shall be equipped with a primary recording element as required by paragraph UR.2.2. **Ticket Printer; Customer Ticket. Recorded Representation**~~

~~(Amended 1993 ~~and 20XX~~)~~

...

S.1.4.2. Printed Ticket Recorded Representation – If a computing-type device issues a ~~printed ticket recorded representation~~ which displays the total computed price, the ~~ticket recorded representation~~ shall ~~also have printed clearly thereon record~~ the total quantity of the delivery, the appropriate fraction of the quantity, and the price per unit of quantity.

(Amended 1989, ~~and 20XX~~)

...

UR.2. User Requirements.

...

UR.2.2. ~~Ticket Printer, Customer Ticket Recording Element.~~ – Vehicle-Mounted metering systems shall be equipped with ~~a ticket printer which shall be used for~~ **means to record** all sales where product is delivered through the meter **and shall comply with G-S.5.6.** A copy of the ticket issued by the device shall be ~~left with~~ **provided to** the customer at the time of delivery or as otherwise specified by the customer.

(Added 1993) (Amended 1994, **and 20XX**)

B4: LPG-21.1 D S.1.1. Primary Elements., UR.2. User Requirements

Item Under Consideration:

Amend Handbook 44, LPG and Anhydrous Ammonia Liquid-Measuring Devices Code as follows:

S.1.1. Primary Elements.

S.1.1.1. General. – A meter shall be equipped with a primary indicating element and may also be equipped with a primary recording element.

Note: Vehicle-mounted metering systems shall be equipped with a primary recording element as required by paragraph UR.2.6. ~~Ticket Printer, Customer Ticket~~ **Recorded Representation**

(Amended 20XX)

...

S.1.1.6. ~~Printed Ticket, Recorded Representation~~ – Any ~~printed ticket issued~~ **recorded representation created** by a device of the computing type ~~on~~ which ~~there is printed~~ **includes** the total computed price, shall ~~have printed clearly~~ **also include** thereon the total volume of the delivery in terms of liters or gallons, and the appropriate decimal fraction of the liter or gallon, and the corresponding price per liter or gallon.

(Added 1979) (Amended 1987, **and 20XX**)

...

S.1.5.5. Recorded Representations for Transactions Where a Post-Delivery Discount(s) is Provided. – Except for fleet sales and other price contract sales, a ~~printed receipt~~ **recorded representation** providing the following information shall be available through a built-in or separate recording element that is part of the system for transactions involving a post-delivery discount:

- (a) the product identity by name, symbol, abbreviation, or code number;
- (b) transaction information as shown on the dispenser at the end of the delivery and prior to any post-delivery discount(s), including the:
 - (1) total volume of the delivery;
 - (2) unit price; and
 - (3) total computed price of the fuel sale.
- (c) an itemization of the post-delivery discounts to the unit price; and

(d) the final total price of the fuel sale after all post-delivery discounts are applied.

(Added 2016) (Amended 20XX)

...

UR.2. User Requirements.

...

UR.2.6. ~~Ticket Printer, Customer Ticket.~~ Recorded Representation– Vehicle-Mounted metering systems shall be equipped with ~~a ticket printer which shall be used for~~ means to record all sales where product is delivered through the meter and shall comply with G-S.5.6. A copy of the ~~ticket-recorded representation~~ issued by the device shall be ~~left with~~ provided to the customer at the time of delivery or as otherwise specified by the customer.

(Added 1993) (Amended 1994, and 20XX)

...

UR.2.7.2. Computing Device. – Any computing device used in an application where a product or grade is offered for sale at one or more unit prices shall be used only for sales for which the device computes and displays the sales price for the selected transaction. The following exceptions apply:

- (a) Fleet sales and other price contract sales are exempt from this requirement.
- (b) A truck stop dispenser used exclusively for refueling trucks is exempt from this requirement provided that:
 - (1) all purchases of fuel are accompanied by a ~~printed receipt~~ recorded representation of the transaction containing the applicable price per unit of measure, the total quantity delivered, and the total price of the sale; and
 - (2) unless a dispenser complies with S.1.5.1. Display of Unit Price, the price posted on the dispenser and the price at which the dispenser is set to compute shall be the highest price for any transaction which may be conducted.
- (c) A dispenser used in an application where a price per unit discount is offered following the delivery is exempt from this requirement, provided the following conditions are satisfied:
 - (1) the unit price posted on the dispenser and the unit price at which the dispenser is set to compute shall be the highest unit price for any transaction;
 - (2) all purchases of fuel are accompanied by a receipt recorded by the system for the transaction containing:
 - a. the product identity by name, symbol, abbreviation, or code number;
 - b. transaction information as shown on the dispenser at the end of the delivery and prior to any post-delivery discount including the:
 - 1. total volume of the delivery;
 - 2. unit price; and
 - 3. total computed price of the fuel sale prior to post-delivery discounts being applied.
 - c. an itemization of the post-delivery discounts to the unit price; and

d. the final total price of the fuel sale after all post-delivery discounts are applied.

(Added 2016) (Amended 20XX)

B4: CLM-21.1 D S.1.4.1. ~~Printed Ticket~~ Recorded Representation., UR.2.6.3. ~~Printed Ticket~~ Recorded Representation.

Item Under Consideration:

Amend Handbook 44, Cryogenic Liquid-Measuring Devices Code as follows:

S.1.4.1 ~~Printed Ticket~~ Recorded Representation – Any ~~printed ticket~~ recorded representation issued by a device of the computing type ~~on which there is printed~~ includes the total computed price ~~shall have printed clearly thereon~~ also include the total quantity of the delivery, and the price per unit.

(Amended 20XX)

And

UR.2.6.2. ~~Tickets or Invoices.~~ Recorded representation– Any ~~written invoice, or printed ticket,~~ recorded representation based on a reading of a device that is equipped with an automatic temperature or density compensator shall have shown thereon that the quantity delivered has been adjusted to the quantity at the NBP of the specific cryogenic product or the equivalent volume of gas at NTP.

(Amended 20XX)

UR.2.6.3. ~~Printed Ticket.~~ Recorded Representation. – Any ~~printed ticket issued~~ recorded representation provided by a device of the computing type ~~on which there is printed~~ includes the total computed price, the total quantity of the delivery, or the price per unit, shall also ~~show~~ include the other two values. ~~(either printed or in clear hand script).~~ and shall comply with G-S.5.6.

(Amended 20XX)

B4: MLK-XX.X D S.1.4.2. ~~Printed Ticket~~ Recorded Representation., UR.2.6.3. ~~Printed Ticket~~ Recorded Representation.

Item Under Consideration:

Amend NIST Handbook 44, Milk Meter Code as follows:

S.1.4.2. ~~Printed Ticket~~ Recorded Representation – If a computing-type device issues a ~~printed ticket~~ recorded representation which ~~displays~~ includes the total computed price, the ~~ticket~~ recorded representation shall ~~also have printed clearly thereon~~ include the total quantity of the delivery, the appropriate fraction of the quantity, and the price per unit of quantity.

(Amended 1989, and 20XX)

UR.2.2. ~~Printed Ticket.~~ Recorded Representation. – Any ~~printed ticket issued~~ recorded representation created by a device of the computing type ~~on which there is printed~~ includes the total computed price, the total quantity, or the price per unit of quantity, shall also ~~show~~ include the other two values ~~(either printed or in clear hand script).~~ and shall comply with G-S.5.6.

(Amended 1989 and 20XX)

B4: MFM-21.2 D S.6. ~~Printer~~ Recorded Representations., UR.2.6. ~~Ticket Printer, Customer Ticket,~~ Recorded Representation., UR.3.4. ~~Printed Ticket.~~ Recorded Representation.

Item Under Consideration:

Amend Handbook 44, Mass Flow Meter Code as follows:

S.6. ~~Printer. Recording Element~~ – When an assembly is equipped with means for ~~printing~~ **recording** the measured quantity, the following conditions apply:

- (a) the scale interval shall be the same as that of the indicator;
- (b) the value of the ~~printed~~ **recorded** quantity shall be the same value as the indicated quantity;
- (c) ~~the printed~~ **recorded** quantity shall also include the mass value if the mass is not the indicated quantity;
[Nonretroactive as of January 1, 2021]
- (d) a quantity for a delivery (other than an initial reference value) cannot be recorded until the measurement and delivery has been completed;
- (e) the ~~printer~~ **recording element** is returned to zero when the resettable indicator is returned to zero; and
- (f) the ~~printed~~ **recorded** values shall meet the requirements applicable to the indicated values.

(Amended 2016, **and 20XX**)

S.6.1. ~~Printed Receipt Recorded Representations.~~ – ~~Any~~ **When a quantity is** delivered, ~~printed quantity the recorded representation~~ shall include an identification number, the time and date, and the name of the seller. This information may be printed by the device or pre-printed on the ticket.

(Amended 20XX)

And

UR.3.3 ~~Ticket Printer, Customer Ticket, Recorded Representation.~~ – Vehicle-Mounted metering systems shall be equipped with ~~a ticket printer which shall be used for~~ **means to record** all sales where product is delivered through the meter **and shall comply with G-S.5.6.** A copy of the ~~ticket recorded representation~~ issued by the device shall be ~~left with~~ **provided to** the customer at the time of delivery or as otherwise specified by the customer.

(Added 19934) **(Amended 20XX)**

...

UR.3.4. ~~Printed Ticket, Recorded Representation.~~ – The total price, the total quantity of the delivery, and the price per unit shall be ~~printed~~ **provided** on any ~~ticket-recorded representation~~ issued by a device of the computing type and containing any one of these values.

(Added 1993) **(Amended 20XX)**

B4: CDL-21.1 D S.1.4.1. ~~Printed Ticket~~Recorded Representations., UR.2.4.2. ~~Tickets or Invoices.~~Recorded Representation.

Item Under Consideration:

Amend Handbook 44, Carbon Dioxide Liquid-Measuring Devices Code as follows:

S.1.4.1. ~~Printed Ticket, Recorded Representation~~– Any ~~printed ticket recorded representation~~ issued by a device of the computing type ~~on~~ which ~~there is printed~~ **includes** the total computed price shall ~~have printed clearly thereon~~ also **include** the total quantity of the delivery and the price per unit.

(Amended 20XX)

UR.2.4.2. ~~Tickets or Invoices Recorded Representation.~~ – Any ~~written invoice or printed ticket recorded representation~~ based on a reading of a device that is equipped with an automatic temperature or density compensator shall ~~have shown thereon~~ **include** that the quantity delivered has been temperature or density compensated.

(Amended 20XX)

B4: HGM-21.1 D S.2.6. Recorded Representations, Point of Sale Systems., S.6. Printer. Recording Element., UR.3.2. Vehicle-mounted Measuring Systems Ticket Printer Recording Element., UR.3.3. Printed Ticket. Recorded Representation.

Item Under Consideration:

Amend Handbook 44, Hydrogen Gas-Measuring Devices Code as follows:

S.2.6. Recorded Representations, Point of Sale Systems. – A ~~printed~~ receipt shall be available through a built-in or separate recording element for transactions conducted with point-of-sale systems or devices activated by debit cards, credit cards, and/or cash. The ~~printed~~ receipt shall contain the following information for products delivered by the dispenser:

- (a) the total mass of the delivery;
- (b) the unit price;
- (c) the total computed price; and
- (d) the product identity by name, symbol, abbreviation, or code number.

(Amended 20XX)

...

S.6. ~~Printer. Recording Element~~ – When an assembly is equipped with means for ~~printing-recording~~ the measured quantity, the ~~printed recorded~~ information must agree with the indications on the dispenser for the transaction and the ~~printed recorded~~ values shall be clearly defined.

(Amended 20XX)

S.6.1. ~~Printed Receipt. Recorded Representation~~ – Any When a quantity is delivered, printed-quantity the recorded representation shall include an identification number, the time and date, and the name of the seller. ~~This information may be printed by the device or pre-printed on the ticket.~~

(Amended 20XX)

And

UR.3.2. Vehicle-mounted Measuring Systems ~~Ticket Printer~~ Recording Element.

(Amended 20XX)

UR.3.2.1. ~~Customer Ticket Recording Element.~~ – Vehicle-Mounted metering systems shall be equipped with ~~a ticket printer which shall be used for~~ means to record all sales where product is delivered through the device and shall comply with G-S.5.6. A copy of the ~~ticket recorded representation~~ issued by the device shall be ~~left with~~ provided to the customer at the time of delivery or as otherwise specified by the customer.

(Amended 20XX)

...

UR.3.3. ~~Printed Ticket. Recorded Representation.~~ – The total price, the total quantity of the delivery, and the price per unit shall be ~~printed~~ provided on any ~~ticket~~ recorded representation issued by a device of the computing type and containing any one of these values.

~~(Added 1993)~~ **(Amended 20XX)**

B4: OTH-21.2 D Appendix D - Definitions.: recorded representations, recording element.

Item Under Consideration:

Amend NIST Handbook 44, Appendix D - Definitions as follows:

recorded representation. – The printed, embossed, **electronic**, or other representation that is recorded as a quantity, **unit price, total price, product identity or other information required** by a weighing or measuring device. [1.10, **2.20, 2.21, 2.22, 2.24, 2.25, 3.30, 3.31, 3.32, 3.33, 3.34, 3.35, 3.36, 3.37, 3.38, 3.39, 3.40, 5.54, 5.55, 5.56(a), 5.56(b), 5.57, 5.58, 5.60**]

recording element. – An element incorporated in a weighing or measuring device by means of which its **the device's** performance relative to quantity or money value is permanently recorded **electronically or** on a tape, ticket, card, or the like, in the form of a printed, stamped, punched, or perforated representation **or recorded electronically in instances where that option is permitted by specific code.** [1.10, **2.20, 2.21, 2.22, 2.24, 2.25, 3.30, 3.31, 3.32, 3.33, 3.34, 3.35, 3.36, 3.37, 3.38, 3.39, 3.40, 5.54, 5.55, 5.56(a), 5.56(b), 5.57, 5.58, 5.60**]

Previous Action:

N/A

Original Justification:

In 2014 G-S.5.6. was added to NIST Handbook 44 to allow for the issuance of electronic receipts. At that time the use of the term “print”, and all variations on the word “print” was not fully addressed.

The Oxford Dictionary defines print as “a mechanical process involving the transfer of text, images, or designs to paper.”

The Oxford Dictionary defines record as: to “set down in writing or some other permanent form for later reference, especially officially.”

Values that are delivered via electronic means are recorded values and not necessarily printed vales. Printed indicates that a value has been transferred on to a hard document. While the intent of the 2014 amendment was to allow for the use of electronic receipts the terminology used is incorrect. In addition to receipts, there are instances where other information may be transmitted electronically.

When applying G-A.2. to weighing and measuring devices,

G-A.2. Code Application. – *This General Code shall apply to all classes of devices as covered in the specific codes. The specific code requirements supersede General Code requirements in all cases of conflict. (Amended 1972),*

multiple conflicts arise in the implementation of the 2014 Amendment of G-S.5.6. This is to clarify the terminology in Handbook44 and to recognize the changing technology in how transactions are recorded, and the information is disseminated.

Comments in Favor:

Regulatory:

- The submitter stated that the item should be developing and noted that updates to the item under consideration were provided to the S&T committee based on reviews that he had with NIST, OWM.

Industry:

- The proposed changes to recognize electronically captured tickets are needed, editorial corrections are needed to some parts of the proposal, and he agreed with a developing status for this item.

Advisory:

- There are two proposed changes to NIST HB 44, Mass Flow Meter Code, Paragraph U.R.3.3 in the 2021 Interim Agenda. One proposal is Block 4 MFM-21.2 UR.3.3. (which was incorrectly number as UR.2.6 in the item under

consideration in the 2021 Interim Meeting agenda) and the other is item MFM-21.1. UR.3.3. on the 2021 Interim Meeting agenda. The submitters should work together to provide one proposed change.

Comments Against:

Regulatory:

-

Industry:

-

Advisory:

-

Neutral Comments:

Regulatory:

-

Industry:

-

Advisory:

-

Item Development:

During the committee's work session, the committee accepted the revision and editorial changes to the item under consideration that were provided by the submitter, Mr. Stutesman. The current Item Under Consideration includes revisions that were provide to the Committee from the submitter of the item and are highlighted in yellow.

NOTE: Below for reference is the proposal as it appeared in the 2021 Interim Meeting agenda.

G-S.5.6. Recorded Representations. – Insofar as they are appropriate, the requirements for indicating and recording elements shall also apply to recorded representations. All recorded values shall be ~~printed~~ **provided** digitally. In applications where recorded representations are required, the customer may be given the option of not receiving the recorded representation. For systems equipped with the capability of issuing an electronic receipt, ticket, or other recorded representation, the customer may be given the option to receive any required information electronically (e.g., via cell phone, computer, etc.) in lieu of or in addition to a hard copy.

(Amended 1975, 2014 and **20XX**)

B4: LMD-21.2 S.1.6.5. Money Value Computations., UR.3. Use of a Device.

Item Under Consideration:

Amend Handbook 44, Liquid Measuring Devices Code as follows:

S.1.6.5. Money-Value Computations

...

S.1.6.5.6. Display of Quantity and Total Price, Aviation Refueling Applications.

(a) The quantity shall be displayed throughout the transaction.

(b) *The total price shall also be displayed under one of the following conditions:*

- (1) The total price can appear on the face of the dispenser or through a controller adjacent to the device.
- (2) If a device is designed to continuously compute and display the total price, then the total price shall be computed and displayed throughout the transaction for the quantity delivered.

(c) *The total price and quantity shall be displayed for at least five minutes or until the next transaction is initiated by using controls on the device or other customer-activated controls.*

(d) *A ~~printed~~ receipt shall be available and shall include, at a minimum, the total price, quantity, and unit price.*

[Nonretroactive as of January 1, 2008]

(Added 2007) (Amended 20XX)

S.1.6.7. Recorded Representations. – *Except for fleet sales and other price contract sales and for transactions where a post-delivery discount is provided, a ~~printed~~ receipt providing the following information shall be available through a built-in or separate recording element for all transactions conducted with point-of-sale systems or devices activated by debit cards, credit cards, and/or cash:*

- (a) *the total volume of the delivery;**
- (b) *the unit price;**
- (c) *the total computed price;**
- (d) *the product identity by name, symbol, abbreviation, or code number;* and*
- (e) *the dispenser designation by either an alphabetical or numerical description.***

**[Nonretroactive as of January 1, 1986] **[Nonretroactive as of January 1, 2021]*

(Added 1985) (Amended 1997, 2012, 2014, 2018 and 20XX)

S.1.6.8. Recorded Representations for Transactions Where a Post-Delivery Discount(s) is Provided. – *Except for fleet sales and other price contract sales, a ~~printed~~ receipt providing the following information shall be available through a built-in or separate recording element that is part of the system for transactions involving a post-delivery discount:*

- (a) the product identity by name, symbol, abbreviation, or code number;
- (b) transaction information as shown on the dispenser at the end of the delivery and prior to any post-delivery discount(s), including the:
 - (1) total volume of the delivery;
 - (2) unit price; and
 - (3) total computed price of the fuel sale.
- (c) an itemization of the post-delivery discounts to the unit price;
- (d) the final total price of the fuel sale after all post-delivery discounts are applied; and
- (e) *the dispenser designation by either an alphabetical or numerical description.*

[Nonretroactive as of January 1, 2021]

(Added 2012) (Amended 2014, and 2018, and 20XX)

...

UR.3. Use of a Device

...

UR.3.3. Computing Device. – Any computing device used in an application where a product or grade is offered for sale at one or more unit prices shall be used only for sales for which the device computes and displays the sales price for the selected transaction.

(Became retroactive 1999)

(Added 1989) (Amended 1992)

The following exceptions apply:

(a) Fleet sales and other price contract sales are exempt from this requirement.

(b) A truck stop dispenser used exclusively for refueling trucks is exempt from this requirement provided that:

(1) all purchases of fuel are accompanied by a **printed** receipt of the transaction containing the applicable price per gallon, the total gallons delivered, and the total price of the sale; and

(Added 1993)

(2) unless a dispenser complies with S.1.6.4.1. Display of Unit Price, the price posted on the dispenser and the price at which the dispenser is set to compute shall be the highest price for any transaction which may be conducted.

(Added 1993)

(c) A dispenser used in an application where a price per unit discount is offered following the delivery is exempt from this requirement, provided the following conditions are satisfied:

(1) the unit price posted on the dispenser and the unit price at which the dispenser is set to compute prior to the application of any discount shall be the highest unit price for any transaction;

(Amended 2014)

(2) all purchases of fuel are accompanied by a receipt recorded by the system. The receipt shall contain:

(a) the product identity by name, symbol, abbreviation, or code number;

(b) transaction information as shown on the dispenser at the end of the delivery and prior to any post-delivery discount including the:

1. total volume of the delivery;

2. unit price; and

3. total computed price of the fuel sale prior to post-delivery discounts being applied.

(c) an itemization of the post-delivery discounts to the unit price; and

(d) the final total price of the fuel sale.

(Added 2012) (Amended 2014)

(Added 1989) (Amended 1992, 1993, 2012, **and 2014, and 20XX**)

UR.3.4. ~~Printed Ticket. Recorded Representation~~ – The total price; the total volume of the delivery; the price per liter or gallon; *and a corresponding alpha or numeric dispenser designation** shall be ~~shown, either printed~~ **recorded** by the device ~~or in clear hand script~~, on any ~~printed ticket issued by a device and~~ **recorded representation** containing any one of these values. Establishments where no product grades are repeated are exempt from the dispenser designation requirement.

**[Nonretroactive as of January 1, 2021]*

(Amended 2001, 2018, and 2019, **and 20XX**)

B4: VTM-21.1 S.1.1. Primary Elements., UR.2. User Requirements

Item Under Consideration:

Amend Handbook 44, Vehicle Tank Meter Code as follows:

S.1.1. Primary Element

S.1.1.1. General. – A meter shall be equipped with a primary indicating ~~element and may also be equipped with a primary recording element.~~ **Except for systems used solely for the sale of aviation fuel into aircraft and for aircraft-related operations, a meter shall be equipped with a primary recording element.**

Note: Except for systems used solely for the sale of aviation fuel into aircraft and for aircraft-related operations, vehicle-tank meters shall be equipped with a primary recording element as required by paragraph UR.2.2. ~~Ticket Printer; Customer Ticket. Recorded Representation.~~

(Amended 1993 **and 20XX**)

...

S.1.4.2. ~~Printed Ticket Recorded Representation~~ – If a computing-type device issues a ~~printed ticket recorded representation~~ which displays the total computed price, the ~~ticket recorded representation~~ shall ~~also have printed clearly thereon record~~ the total quantity of the delivery, the appropriate fraction of the quantity, and the price per unit of quantity.

(Amended 1989, **and 20XX**)

...

UR.2. User Requirements.

...

UR.2.2. ~~Ticket Printer, Customer Ticket Recording Element.~~ – Vehicle-Mounted metering systems shall be equipped with a ~~ticket printer which shall be used for means to record~~ all sales where product is delivered through the meter. A copy of the ticket issued by the device shall be ~~left with~~ **provided to** the customer at the time of delivery or as otherwise specified by the customer.

(Added 1993) (Amended 1994, **and 20XX**)

B4: LPG-21.1 S.1.1. Primary Elements., UR.2. User Requirements

Item Under Consideration:

Amend Handbook 44, LPG and Anhydrous Ammonia Liquid-Measuring Devices Code as follows:

S.1.1. Primary Elements.

S.1.1.1. General. – A meter shall be equipped with a primary indicating element and may also be equipped with a primary recording element.

Note: Vehicle-mounted metering systems shall be equipped with a primary recording element as required by paragraph UR.2.6. ~~Ticket Printer; Customer Ticket. Recorded Representation~~

(Amended 20XX)

...

S.1.1.6. ~~Printed Ticket, Recorded Representation~~ – Any ~~printed ticket issued~~ **recorded representation** created by a device of the computing type ~~on which there is printed~~ **includes** the total computed price, shall ~~have printed clearly~~ **also include** thereon the total volume of the delivery in terms of liters or gallons, and the appropriate decimal fraction of the liter or gallon, and the corresponding price per liter or gallon.

(Added 1979) (Amended 1987, and 20XX)

...

S.1.5.5. Recorded Representations for Transactions Where a Post-Delivery Discount(s) is Provided. – Except for fleet sales and other price contract sales, a ~~printed receipt~~ **recorded representation** providing the following information shall be available through a built-in or separate recording element that is part of the system for transactions involving a post-delivery discount:

- (e) the product identity by name, symbol, abbreviation, or code number;
- (f) transaction information as shown on the dispenser at the end of the delivery and prior to any post-delivery discount(s), including the:
 - (1) total volume of the delivery;
 - (2) unit price; and
 - (3) total computed price of the fuel sale.
- (g) an itemization of the post-delivery discounts to the unit price; and
- (h) the final total price of the fuel sale after all post-delivery discounts are applied.

(Added 2016) (Amended 20XX)

...

UR.2. User Requirements.

...

UR.2.6. ~~Ticket Printer, Customer Ticket, Recorded Representation~~– Vehicle-Mounted metering systems shall be equipped with ~~a ticket printer which shall be used for~~ **means to record** all sales where product is delivered through the meter. A copy of the ~~ticket~~ **recorded representation** issued by the device shall be ~~left with~~ **provided to** the customer at the time of delivery or as otherwise specified by the customer.

(Added 1993) (Amended 1994, and 20XX)

...

UR.2.7.2. Computing Device. – Any computing device used in an application where a product or grade is offered for sale at one or more unit prices shall be used only for sales for which the device computes and displays the sales price for the selected transaction. The following exceptions apply:

- (d) Fleet sales and other price contract sales are exempt from this requirement.
- (e) A truck stop dispenser used exclusively for refueling trucks is exempt from this requirement provided that:

- (1) all purchases of fuel are accompanied by a ~~printed receipt~~ **recorded representation** of the transaction containing the applicable price per unit of measure, the total quantity delivered, and the total price of the sale; and
 - (2) unless a dispenser complies with S.1.5.1. Display of Unit Price, the price posted on the dispenser and the price at which the dispenser is set to compute shall be the highest price for any transaction which may be conducted.
- (f) A dispenser used in an application where a price per unit discount is offered following the delivery is exempt from this requirement, provided the following conditions are satisfied:
- (1) the unit price posted on the dispenser and the unit price at which the dispenser is set to compute shall be the highest unit price for any transaction;
 - (2) all purchases of fuel are accompanied by a receipt recorded by the system for the transaction containing:
 - a. the product identity by name, symbol, abbreviation, or code number;
 - b. transaction information as shown on the dispenser at the end of the delivery and prior to any post-delivery discount including the:
 - i. total volume of the delivery;
 - ii. unit price; and
 - iii. total computed price of the fuel sale prior to post-delivery discounts being applied.
 - c. an itemization of the post-delivery discounts to the unit price; and
 - d. the final total price of the fuel sale after all post-delivery discounts are applied.

(Added 2016) **(Amended 20XX)**

B4: CLM-21.1 **S.1.4.1. ~~Printed Ticket~~ Recorded Representation., UR.2.6.3. ~~Printed Ticket~~Recorded Representation.**

Item Under Consideration:

Amend Handbook 44, Cryogenic Liquid-Measuring Devices Code as follows:

S.1.4.2. ~~Printed Ticket~~ Recorded Representation – If a computing-type device issues a ~~printed ticket~~ **recorded representation** which ~~displays~~ **includes** the total computed price, the ~~ticket~~ **recorded representation** shall ~~also have printed clearly thereon~~ **include** the total quantity of the delivery, the appropriate fraction of the quantity, and the price per unit of quantity.

(Amended 1989, and 20XX)

And

UR.2.6.3. Printed Ticket. Recorded Representation. – Any ~~printed ticket issued~~ **recorded representation created** by a device of the computing type ~~on which there is printed~~ **includes** the total computed price, the total quantity of the delivery, or the price per unit, shall also ~~show~~ **include** the other two values (~~either printed or in clear hand script~~).

(Amended 20XX)

B4: MFM-21.2 S.6. ~~Printer~~Recorded Representations., UR.2.6. ~~Ticket Printer, Customer Ticket,~~ Recorded Representation., UR.3.4. ~~Printed Ticket.~~ Recorded Representation.

Item Under Consideration:

Amend Handbook 44, Mass Flow Meter Code as follows:

S.6. ~~Printer. Recording Element~~ – When an assembly is equipped with means for ~~printing~~recording the measured quantity, the following conditions apply:

- (a) the scale interval shall be the same as that of the indicator;
- (b) the value of the ~~printed~~recorded quantity shall be the same value as the indicated quantity;
- (c) *the ~~printed~~recorded quantity shall also include the mass value if the mass is not the indicated quantity;*

[Nonretroactive as of January 1, 2021]

- (d) a quantity for a delivery (other than an initial reference value) cannot be recorded until the measurement and delivery has been completed;
- (e) the ~~printer~~recording element is returned to zero when the resettable indicator is returned to zero; and
- (f) the ~~printed~~recorded values shall meet the requirements applicable to the indicated values.

(Amended 2016, and 20XX)

S.6.1. ~~Printed Receipt~~ Recorded Representations. – ~~Any~~When a quantity is delivered, ~~printed quantity the recorded representation~~ shall include an identification number, the time and date, and the name of the seller. ~~This information may be printed by the device or pre-printed on the ticket.~~

(Amended 20XX)

And

UR.2.6. ~~Ticket Printer, Customer Ticket,~~ Recorded Representation. – Vehicle-Mounted metering systems shall be equipped with ~~a ticket printer which shall be used for~~ means to record all sales where product is delivered through the meter. A copy of the ~~ticket~~recorded representation issued by the device shall be ~~left with~~ provided to the customer at the time of delivery or as otherwise specified by the customer.

(Added 1993) (Amended 1994, and 20XX)

...

UR.3.4. ~~Printed Ticket.~~ Recorded Representation. – The total price, the total quantity of the delivery, and the price per unit shall be ~~recorded~~ provided on any ~~ticket~~ recorded representation issued by a device of the computing type and containing any one of these values.

(Added 1993) (Amended 20XX)

B4: CDL-21.1 S.1.4.1. ~~Printed Ticket~~Recorded Representations., UR.2.4.2. ~~Tickets or Invoices.~~ Recorded Representation.

Item Under Consideration:

Amend Handbook 44, Carbon Dioxide Liquid-Measuring Devices Code as follows:

S.1.4.1. ~~Printed Ticket.~~ Recorded Representation – Any ~~printed ticket~~ recorded representation issued by a device of the computing type on which **there is printed** includes the total computed price shall **have printed clearly thereon** also include the total quantity of the delivery and the price per unit.

(Amended 20XX)

UR.2.4.2. ~~Tickets or Invoices~~ Recorded Representation. – Any ~~written invoice or printed ticket~~ recorded representation based on a reading of a device that is equipped with an automatic temperature or density compensator shall ~~have shown thereon~~ include that the quantity delivered has been temperature or density compensated.

(Amended 20XX)

**B4: HGM-21.1 S.2.6. Recorded Representations, Point of Sale Systems., S.6. Printer. Recording Element.,
UR.3.2. Vehicle-mounted Measuring Systems Ticket Printer Recording Element., UR.3.3. Printed Ticket. Recorded
Representation.**

Item Under Consideration:

Amend Handbook 44, Hydrogen Gas-Measuring Devices Code as follows:

S.2.6. Recorded Representations, Point of Sale Systems. – A ~~printed~~ receipt shall be available through a built-in or separate recording element for transactions conducted with point-of-sale systems or devices activated by debit cards, credit cards, and/or cash. The ~~printed~~ receipt shall contain the following information for products delivered by the dispenser:

- (a) the total mass of the delivery;
- (b) the unit price;
- (c) the total computed price; and
- (d) the product identity by name, symbol, abbreviation, or code number.

(Amended 20XX)

...

S.6. ~~Printer. Recording Element~~ – When an assembly is equipped with means for ~~printing-recording~~ the measured quantity, the ~~printed-recorded~~ information must agree with the indications on the dispenser for the transaction and the ~~printed recorded~~ values shall be clearly defined.

(Amended 20XX)

S.6.1. ~~Printed Receipt.~~ Recorded Representation – ~~Any~~ When a quantity is delivered, ~~printed-quantity the recorded representation~~ shall include an identification number, the time and date, and the name of the seller. ~~This information may be printed by the device or pre-printed on the ticket.~~

(Amended 20XX)

And

UR.3.2. Vehicle-mounted Measuring Systems ~~Ticket Printer~~ Recording Element.

(Amended 20XX)

UR.3.2.1. ~~Customer Ticket Recording Element.~~ – Vehicle-Mounted metering systems shall be equipped with ~~a ticket printer which shall be used for means to record~~ all sales where product is delivered through the meter. A copy of the ~~ticket recorded representation~~ issued by the device shall be ~~left with~~ **provided to** the customer at the time of delivery or as otherwise specified by the customer.

(Amended 20XX)

...

UR.3.3. ~~Printed Ticket. Recorded Representation.~~ – The total price, the total quantity of the delivery, and the price per unit shall be recorded on any ticket issued by a device of the computing type and containing any one of these values.

(Added 1993) **(Amended 20XX)**

B4: OTH-21.2 Appendix D - Definitions.: recorded representations, recording element.

Item Under Consideration:

Amend Handbook 44, Appendix D - Definitions as follows:

recorded representation. – The printed, embossed, **electronic**, or other representation that is recorded as a quantity, **unit price, total price, product identity or other information required** by a weighing or measuring device. [1.10, **2.20, 2.21, 2.22, 2.24, 2.25, 3.30, 3.31, 3.32, 3.33, 3.34, 3.35, 3.36, 3.37, 3.38, 3.39, 3.40, 5.54, 5.55, 5.56(a), 5.56(b), 5.57, 5.58, 5.60**]

recording element. – An element incorporated in a weighing or measuring device by means of which its performance relative to quantity or money value is permanently recorded **electronically or** on a tape, ticket, card, or the like, in the form of a printed, stamped, punched, or perforated representation. [1.10, **2.20, 2.21, 2.22, 2.24, 2.25, 3.30, 3.31, 3.32, 3.33, 3.34, 3.35, 3.36, 3.37, 3.38, 3.39, 3.40, 5.54, 5.55, 5.56(a), 5.56(b), 5.57, 5.58, 5.60**]

Regional Association Comments:

WWMA 2020 Annual Meeting: No comments were received during open hearings. However, the submitter did provide additional changes and continues to develop the item. The Committee recommends this block be given Developing status.

SWMA 2020 Annual Meeting: During the Open Hearings, the Committee heard from Dianne Lee (OWM) who stated that the purpose of this item is to allow an option for an electronic ticket by revising the language of the Recording Requirements in Handbook 44. She also stated that NIST OWM supports this block. The Committee also heard from Hal Prince (Florida) that electronic tickets are already allowed, and that this revision would allow electronic only tickets. The Committee also heard from Tina Butcher (OWM) who stated that she had the same concerns as Hal but was assured the intent was only to allow an electronic option for customers. The Committee also heard from Ken Ramsburg (Maryland) who stated that he agreed with Hal Prince, and that the General Code already covered this. The Committee also heard from Tory Brewer (West Virginia) who stated that he was concerned that this item would make it difficult for customers to receive a printed ticket if it was not set as a default, and how the customer would choose a printed ticket instead of an electronic one. Tina Butcher also stated that Specific Code superseded the General Code, so that is why a change is likely needed to allow electronic tickets.

After considering this item the Committee recommends that it be given Developing Status.

NEWMA 2020 Interim Meeting: The Committee agrees with the body that the revised edition of this proposal has been fully developed by the submitter and recommends it move forward as a Voting Item. Discussion was heard both for and against the proposal. Comments against the proposal included that there was no significant change or that the location in the handbook was not appropriate or may conflict with current State laws regarding electronic records. Comments in favor of the proposal were that it allowed clarity through definitions and where “printed” hard copies are currently required, allows for an electronic option without adding conflict.

CWMA 2020 Interim Meeting: Mr. Charlie Stutesman (KS) the developer of the item gave a presentation to the S&T committee updating the current changes on the item. The committee received comments from both regulatory officials and industry representatives expressing a need for this item. The Committee feels this item is fully developed and we recommend this item move forward as a Voting item.

Additional letters, presentation and data may have been submitted for consideration with this item. Please refer to <https://www.ncwm.com/publication-16> to review these documents.

| CWMA Report |
|--|
| Comments and justification for the regional recommendation to NCWM: <i>(This will appear in NCWM reports)</i> |
| Charlie Stutesman (KS), the developer of this item gave a brief update and requested that this item remains developing. Diane Lee (NIST OWM) supports continuing development of this item. Russ Vires (SMA) supports continuing development of this item. Loren Minnich (KS) submitted suggested changes to developer. Included in Appendix at the end of this report. He thought G-S.5.6. is getting too wordy and should be simplified to allow specific codes to speak for themselves. The CWMA S&T Committee recommends that this Item Block remain a Developing. |

BLOCK 1 ITEMS (B1) TERMINOLOGY FOR TESTING STANDARDS (VERIFICATION STANDARDS, FIELD STANDARDS, TRANSFER STANDARDS, FIELD REFERENCE STANDARDS, ETC.,) TOLERANCES ON TESTS WHEN TRANSFER STANDARDS ARE USED, MINIMUM QUANTITY FOR FIELD REFERENCE STANDARD METER TESTS

NOTE: During the 2019 NCWM Interim Meeting, the S&T Committee considered the comments during the opening hearing and recommended that the following items appearing on the 2019 Agenda B1, B2, LPG-3 and MFM-5 be combined with GEN-3 and gave these items an assign status. This block of items (“New” BLOCK 1) now includes previously numbered items: GEN-3; Block 1; Block 2; LPG-3; and MFM-5. The Item Under Consideration for all individual items has been included in the listing that follows.

Source:

NIST OWM, Endress + Hauser Flowtec AG USA (2018), and Seraphin Test Measure Co. (2019)

Purpose:

- (a) Add a definition for field standard that identifies the critical characteristics for field standards to comply with the Fundamental Considerations of Handbook 44; and
- (b) To add a generalized definition for transfer standards in Handbook 44 to clearly include the transfer standards already referenced in various codes; and
- (c) To specify that when a transfer standard is used, the basic tolerances specified in Handbook 44 be increased by the amount of the estimated uncertainty associated with the transfer standard
- (d) To remove the current limited definition and use of the term “Transfer Standard” and eliminate terms “Testing Standards”, “Verification (Testing) Standards”, and instead use the term Field Standard, consistent with its reference in Handbook 44, Appendix A, Fundamental Considerations and its use in several sections of Handbook 44. To correct the broad use of the term Transfer Standard and instead replace its use with the term Field Standard. To update all use of the term “standard” to use the term “Field Standard”. To remove the current limited definition of Transfer Standard and instead use the term Field Standard.

B1: GEN-19.1 A G-T.5. Tolerances on Tests When Transfer Standards are Used., Appendix D – Definitions: standards, field., ~~transfer standard.~~ and standard, transfer.

Source:

Seraphin Test Measure Co.

Purpose:

- (e) Add a definition for field standard that identifies the critical characteristics for field standards to comply with the Fundamental Considerations of Handbook 44 (specifically, a standard that has long-term stability and meets the one-

third requirement for accuracy and uncertainty over the range of environmental and operational variables in which commercial measuring devices are used); and

- (f) To add a generalized definition for transfer standards in Handbook 44 to clearly include the transfer standards already referenced in various codes; and
- (g) To specify that when a transfer standard is used, the basic tolerances specified in Handbook 44 be increased the amount of the estimated uncertainty associated with the transfer standard.

Item Under Consideration:

Amend Handbook 44, General Code as follows:

G-T.5. Tolerances on Tests When Transfer Standards Are Used. – To the basic tolerance values that would otherwise be applied, there shall be added an amount equal to two times the standard deviation of the applicable transfer standard when compared to a basic reference standard.

The codes 5.56.(a) Grain Moisture Meters, 5.56.(b) Grain Moisture Meters, and 5.57. Near-Infrared Grain Analyzers are exempt from this requirement, because NIST Handbook 159 has requirements for monitoring and retesting grain samples to ensure adequate stability and the tolerances for the devices under test already incorporate the uncertainty associated with the use of grain samples as transfer standards. The code 2.21. Belt-Conveyor Scale Systems is also exempt, because relative and absolute tolerances are included in the code.

And amend Handbook 44 Appendix D – Definitions as follows:

Standard, Field. – A physical standard that (a) is stable (accurate and repeatable) over an extended period of time (typically one year) and (b) meets the specifications and tolerances in NIST Handbook 105- series standards (or other suitable and designated standards) over the range of environmental and operational parameters in which the commercial measuring devices are used and is traceable to the reference or working standards through comparisons, using acceptable laboratory procedures, and used in conjunction with commercial weighing and measuring equipment. “Other suitable and designated standards” must show that the field standards have been tested over the range of environmental and operational parameters in which the commercial measuring devices under test are used and prove that the performance of the field standard meets the requirements of the fundamental considerations.

~~transfer standard. – A measurement system designed for use in proving and testing cryogenic liquid measuring devices. [3.38]~~

Standard, Transfer. – A physical artifact, static or dynamic measurement device or a reference material that is stable (accurate and repeatable) for a short time period under the limited environmental and operational conditions during which the transfer standard is used. A transfer standard may be used as a temporary measurement reference to check the accuracy of a commercial measuring instrument, but the transfer standard does not satisfy the NIST Handbook 44 Fundamental Consideration that its correction and uncertainty are less than one-third of the smallest tolerance applied to the commercial measuring instrument under test, either over a long time period or a wide range of environmental or operating parameters. Transfer standards are called by different terms in different Handbook 44 codes and include terms such as master meter, fifth wheel, material, reference weight [railroad] cars, test vehicles and reference vehicle.

**BLOCK 1 ITEMS (B1) A TERMINOLOGY FOR TESTING STANDARDS
(original B1 items)**

Source:
NIST OWM

Purpose:

To remove the current limited definition and use of the term “Transfer Standard” and eliminate terms “Testing Standards”, “Verification (Testing) Standards”, and instead use the term Field Standard, consistent with its reference in Handbook 44, Appendix A, Fundamental Considerations and its use in several sections of Handbook 44. To correct the broad use of the term Transfer Standard and instead replace its use with the term Field Standard. To update all use of the term “standard” to use the term “Field Standard”. To remove the current limited definition of Transfer Standard and instead use the term Field Standard.

B1: SCL-18.1 A N.2. Verification (Testing) Standards

Item Under Consideration:

Amend Handbook 44, Scales Code as follows:

N.2. ~~Verification (Testing)~~ **Field Standards.** – Field standard weights used in verifying weighing devices shall comply with requirements of NIST Handbook 105-Series standards (or other suitable and designated standards) or the tolerances expressed in Fundamental Considerations, paragraph 3.2. (i.e., one-third of the smallest tolerance applied).
(Amended 1986 ~~and 20XX~~)

B1: ABW-18.1 A N.2. Verification (Testing) Standards

Item Under Consideration:

Amend Handbook 44, Automatic Bulk Weighing Systems Code as follows:

N.2. ~~Verification (Testing)~~ **Field Standards.** – ~~Field S~~ **Field Standard** weights and masses used in verifying weighing devices shall comply with requirements of NIST Handbook 105-1 (Class F) or the tolerances expressed in Appendix A, Fundamental Considerations, paragraph 3.2. (i.e., one-third of the smallest tolerance applied).
(~~Amended 20XX~~)

B1: AWS-18.1 A N.1.3. Verification (Testing) Standards, N.3.1. Official Tests, UR.4. Testing Standards

Item Under Consideration:

Amend Handbook 44, Automatic Weighing Systems Code as follows:

N.1.3. ~~Verification (Testing)~~ **Field Standards.** – Field standard weights shall comply with requirements of NIST Handbook 105-1, “Specifications and Tolerances for Field Standard Weights (Class F)” or the tolerances expressed in Fundamental Considerations, paragraph 3.2. (i.e., one-third of the smallest tolerance applied).
(~~Amended 20XX~~)

N.3.1. **Official Tests.** – Officials are encouraged to periodically witness the required “in house” verification of accuracy. Officials may also conduct official tests using the on-site ~~testing field~~ standards or other appropriate standards belonging to the jurisdiction with statutory authority over the device or system.
(~~Amended 20XX~~)

UR.4. ~~Testing Field~~ **Standards.** – The user of a commercial device shall make available to the official with statutory authority over the device ~~testing field~~ standards that meet the tolerance expressed in Fundamental Considerations, paragraph 3.2. Tolerances for Standards (i.e., one-third of the smallest tolerance applied). The accuracy of the ~~testing field~~ standards shall be verified annually or on a frequency as required by the official with statutory authority and shall be traceable to the appropriate SI standard.

(Amended 20XX)

B1: CLM-18.1 A N.3.2. Transfer Standard Test and T.3. On Tests Using Transfer Standards

Item Under Consideration:

Amend Handbook 44, Cryogenic Liquid-Measuring Devices Code as follows:

N.3.2. Transfer Field Standard Test. – When comparing a meter with a calibrated ~~transfer~~ **field** standard, the test draft shall be equal to at least the amount delivered by the device in two minutes at its maximum discharge rate, and shall in no case be less than 180 L (50 gal) or equivalent thereof. When testing uncompensated volumetric meters in a continuous recycle mode, appropriate corrections shall be applied if product conditions are abnormally affected by this test mode.

(Amended 1976 and 20XX)

~~**T.3. On Tests Using Transfer Standards.**—To the basic tolerance values that would otherwise be applied, there shall be added an amount equal to two times the standard deviation of the applicable transfer standard when compared to a basic reference standard. (Added 1976)~~

B1: CDL-18.1 A N.3.2. Transfer Standard Test, T.3. On Tests Using Transfer Standards

Item Under Consideration:

Amend Handbook 44, Carbon Dioxide Liquid-Measuring Devices Code as follows:

N.3.2. Transfer Field Standard Test. – When comparing a meter with a calibrated ~~transfer~~ **field** standard, the test draft shall be equal to at least the amount delivered by the device in two minutes at its maximum discharge rate.

(Amended 20XX)

~~**T.3. On Tests Using Transfer Standards.**—To the basic tolerance values that would otherwise be applied, there shall be added an amount equal to two times the standard deviation of the applicable transfer standard when compared to a basic reference standard.~~

B1: HGM-18.1 A N.4.1. Master Meter (Transfer) Standard Test, T.4. Tolerance Application on Test Using Transfer Standard Test Method

Item Under Consideration:

Amend Handbook 44, Hydrogen Gas-Measuring Devices Tentative Code as follows:

N.4.1. Master Meter (~~Transfer~~) Field Standard Test. – When comparing a measuring system with a calibrated ~~transfer~~ **field** standard, the minimum test shall be one test draft at the declared minimum measured quantity and one test draft at approximately ten times the minimum measured quantity or 1 kg, whichever is greater. More tests may be performed over the range of normal quantities dispensed.

(Amended 20XX)

~~**T.4. Tolerance Application on Test Using Transfer Standard Test Method.**—To the basic tolerance values that would otherwise be applied, there shall be added an amount equal to two times the standard deviation of the applicable transfer standard when compared to a basic reference standard.~~

B1: GMM-18.1A 5.56(a): N.1.1. Air Oven Reference Method Transfer Standards, N.1.3. Meter to Like-Type Meter Method Transfer Standards and 5.56(b): N.1.1. Transfer Standards, T. Tolerances¹

Item Under Consideration:

Amend Handbook 44, Grain Moisture Meters Code as follows:

5.56.(a) Grain Moisture Meters

N.1.1. Air Oven Reference Method ~~Transfer~~ Field Standards. – Official grain samples shall be used as the official ~~transfer field~~ standards with moisture content and test weight per bushel values assigned by the reference methods. The reference methods for moisture shall be the oven drying methods as specified by the USDA GIPSA. The test weight per bushel value assigned to a test weight transfer standard shall be the average of 10 test weight per bushel determinations using the quart kettle test weight per bushel apparatus as specified by the USDA GIPSA. Tolerances shall be applied to the average of at least three measurements on each official grain sample. Official grain samples shall be clean and naturally moist, but not tempered (i.e., water not added). (Amended 1992, 2001, ~~and~~ 2003, and 20XX)

N.1.3. Meter to Like-Type Meter Method Transfer Standards. – Properly standardized reference meters using National Type Evaluation Program approved calibrations shall be used as ~~transfer field~~ standards. A reference meter shall be of the same type as the meter under test. Tests shall be conducted side-by-side using, as a comparison medium, grain samples that are clean and naturally moist, but not tempered (i.e., water not added). (Added 2001) (Amended 20XX)

5.56.(b) Grain Moisture Meters

N.1.1. ~~Transfer~~ Field Standards. – Official grain samples shall be used as the official ~~transfer field~~ standards with moisture content values assigned by the reference methods. The reference methods shall be the oven drying methods as specified by the USDA GIPSA. Tolerances shall be applied to the average of at least three measurements on each official grain sample. Official grain samples shall be clean and naturally moist, but not tempered (i.e., water not added). (Amended 1992 and 20XX)

T. Tolerances¹

¹These tolerances do not apply to tests in which grain moisture meters are the ~~transfer field~~ standards. (Amended 20XX)

B1: LVS-18.1 A N.2. Testing Standards

Item Under Consideration:

Amend Handbook 44, Electronic Livestock, Meat and Poultry Evaluation Systems and/or Devices Code as follows:

N.2. ~~Testing~~ Field Standards. – ASTM Standard F2343 requires device or system users to maintain accurate ~~reference~~ field standards that meet the tolerance expressed in NIST Handbook 44 Fundamental Considerations, paragraph 3.2. Tolerances for Standards (i.e., one-third of the smallest tolerance applied). (Amended 20XX)

B1: OTH-18.1 A Appendix A: Fundamental Considerations, 3.2. Tolerances for Standards, 3.3. Accuracy of Standards

Item Under Consideration:

Amend Handbook 44, Appendix A: Fundamental Considerations as follows:

3.2. Tolerances for Field Standards. – Except for work of relatively high precision, it is recommended that the accuracy of standards used in testing commercial weighing and measuring equipment be established and maintained so that the use of corrections is not necessary. When the standard is used without correction, its combined error and uncertainty must be less than one-third of the applicable device tolerance.

Device testing is complicated to some degree when corrections to standards are applied. When using a correction for a standard, the uncertainty associated with the corrected value must be less than one-third of the applicable device tolerance. The reason for this requirement is to give the device being tested as nearly as practicable the full benefit of its own tolerance.

(Amended 20XX)

3.3. Accuracy of Field Standards. – Prior to the official use of testing apparatus, its accuracy should invariably be verified. Field standards should be calibrated as often as circumstances require. By their nature, metal volumetric field standards are more susceptible to damage in handling than are standards of some other types. A field standard should be calibrated whenever damage is known or suspected to have occurred or significant repairs have been made. In addition, field standards, particularly volumetric standards, should be calibrated with sufficient frequency to affirm their continued accuracy, so that the official may always be in an unassailable position with respect to the accuracy of his testing apparatus. Secondary field standards, such as special fabric testing tapes, should be verified much more frequently than such basic standards as steel tapes or volumetric provers to demonstrate their constancy of value or performance.

Accurate and dependable results cannot be obtained with faulty or inadequate field standards. If either the service person or official is poorly equipped, their results cannot be expected to check consistently. Disagreements can be avoided and the servicing of commercial equipment can be expedited and improved if service persons and officials give equal attention to the adequacy and maintenance of their testing apparatus.

(Amended 20XX)

B1: OTH-18.2 A Appendix D – Definitions: ~~fifth-wheel, official grain samples, transfer standard and Standard, Field~~

Item Under Consideration:

Amend Handbook 44, Appendix A: Fundamental Considerations as follows:

fifth wheel. – A commercially-available distance-measuring device which, after calibration, is recommended for use as a field ~~transfer~~ standard for testing the accuracy of taximeters and odometers on rented vehicles. [5.53, 5.54]

(Amended 20XX)

official grain samples. – Grain or seed used by the official as the official ~~transfer field~~ standard from the reference standard method to test the accuracy and precision of grain moisture meters. [5.56(a), 5.56(b)]

(Amended 20XX)

~~transfer standard. – A measurement system designed for use in proving and testing cryogenic liquid measuring devices. [3.38]~~

Standard, Field. – **A physical standard that meets specifications and tolerances in NIST Handbook 105-series standards (or other suitable and designated standards) and is traceable to the reference or working standards through comparisons, using acceptable laboratory procedures, and used in conjunction with commercial weighing and measuring equipment.**

(Added 20XX)

BLOCK 1 ITEMS (B1) A DEFINE “FIELD REFERENCE STANDARD”
(original block 2 items)

Source:

Endress + Hauser Flowtec AG USA

B1: CLM-18.2 A N.3.2. Transfer Standard Test and T.3. On Tests Using Transfer Standards

Item Under Consideration:

Amend Handbook 44, Cryogenic Liquid-Measuring Devices Code as follows:

N.3.2. Field Reference~~Transfer Standard~~ Meter Test. – When comparing a meter with a calibrated **field referencetransfer** standard **meter**, the test draft shall be equal to at least the amount delivered by the device in two minutes at its maximum discharge rate, and shall in no case be less than 180 L (50 gal) or equivalent thereof. When testing

uncompensated volumetric meters in a continuous recycle mode, appropriate corrections shall be applied if product conditions are abnormally affected by this test mode.

(Amended 1976 ~~and 20XX~~)

T.3. On Tests Using Field Reference~~Transfer~~ Standards Meters. – To the basic tolerance values that would otherwise be applied, there shall be added an amount equal to two times the standard deviation of the applicable field ~~reference~~~~transfer~~ standard meter when compared to a basic reference standard. (Added 1976)

B1: CDL-18.2 A N.3.2. Transfer Standard Test and T.3. On Tests Using Transfer Standards

Item Under Consideration:

Amend Handbook 44, Carbon Dioxide Liquid-Measuring Devices Code as follows:

N.3.2. Field Reference~~Transfer~~ Standard Meter Test. – When comparing a meter with a calibrated field ~~reference~~~~transfer~~ standard meter, the test draft shall be equal to at least the amount delivered by the device in two minutes at its maximum discharge rate.

(Amended 20XX)

T.3. On Tests Using Field Reference~~Transfer~~ Standards Meters. – To the basic tolerance values that would otherwise be applied, there shall be added an amount equal to two times the standard deviation of the applicable field ~~reference~~~~transfer~~ standard when compared to a basic field reference~~reference~~ standard meter.

B1: HGM-18.2 A N.4.1. Master Meter (Transfer) Standard Test and T.4. Tolerance Application on Test Using Transfer Standard Test Method

Item Under Consideration:

Amend Handbook 44, Hydrogen Gas-Measuring Devices Tentative Code as follows:

N.4.1. Field Reference~~Master Meter (Transfer)~~ Standard Meter Test. – When comparing a measuring system with a calibrated field reference~~transfer~~ standard meter, the minimum test shall be one test draft at the declared minimum measured quantity and one test draft at approximately ten times the minimum measured quantity or 1 kg, whichever is greater. More tests may be performed over the range of normal quantities dispensed.

(Amended 20XX)

T.4. Tolerance Application on Test Using Field Reference~~Transfer~~ Standard Meters Test Method. – To the basic tolerance values that would otherwise be applied, there shall be added an amount equal to two times the standard deviation of the applicable field reference~~transfer~~ standard meter when compared to a basic reference standard.

B1: OTH-18.3 A Appendix D – Definitions: field reference standard meter ~~and transfer standard~~

Item Under Consideration:

Amend Handbook 44, Appendix D as follows:

field reference standard meter – A measurement system designed for use in proving and testing measuring devices and meters.

~~transfer standard~~ – A measurement system designed for use in proving and testing cryogenic liquid measuring devices.

B1: LPG-15.1 A N.3. Test Drafts.

Source:

Endress + Hauser Flowtec AG USA

Item Under Consideration:

Amend Handbook 44, LPG and Anhydrous Ammonia Liquid-Measuring Devices as follows:

N.3. Test Drafts.

N.3.1 Minimum Test - Test drafts should be equal to at least the amount delivered by the device in 1 minute at its normal discharge rate.

(Amended 1982)

N.3.2. Field Reference Standard Meter Test. – The minimum quantity for any test draft shall be equal to or greater than the amount delivered in one minute at the flow rate being tested.

(Added 20XX)

B1: MFM-15.1 A N.3. Test Drafts.

Source:

Endress + Hauser Flowtec AG USA

Item Under Consideration:

Amend Handbook 44, Mass Flow Meters Code as follows:

N.3. Test Drafts. –

N.3.1 Minimum Test - The minimum test shall be one test draft at the maximum flow rate of the installation and one test draft at the minimum flow rate. More tests may be performed at these or other flow rates. (See T.3. Repeatability.)

(Amended 1982 **and 20XX**)

N.3.2. Field Reference Standard Meter Test. – The minimum quantity for any test draft shall be equal to or greater than the amount delivered in one minute at the flow rate being tested.

(Added 20XX)

Background/Discussion:

These items have been assigned to the Field Standards Task Group for further development. For more information or to provide comment, please contact the task group chair:

Mr. Jason Glass
Kentucky Department of Agriculture
502-573-0282, jason.glass@ky.gov

The term transfer standard is currently defined in HB 44 as only being applicable to the Cryogenic Liquid Measuring Devices Code. This definition should be removed as it is very limited in scope and the item termed a ‘transfer standard’ is in fact a robust working measurement standard used in field conditions, better termed and shortened to Field Standard. All instruments/devices used as a Field Standard in the testing of Weighing and Measuring Devices, regardless of nomenclature, must comply with the requirements of HB 44, Appendix A, Fundamental Considerations Associated with the Enforcement of Handbook 44 Codes, paragraph 3.2 Testing Apparatus, Adequacy. Using the term transfer standard as it is recently being applied in no way negates this requirement of adequacy and confuses the user as to the nature of the field standard being used.

Use of the single word ‘standard’ to signify use of a field standard can be confusing as there are a number of different meanings associated with “standard.” It could be a documentary standard, i.e., HB 44; a primary standard used to realize the SI, i.e., Watt

Balance; a laboratory reference standard used to ensure traceability of laboratory measurements to the SI, i.e., NIST calibrated laboratory standards; a laboratory check standard used to monitor the laboratory process. Use of the single word ‘standard’ requires that the reader understand completely the context of its use. Instead, using the term “Field Standard” ensures that the reader understands that the item described is a robust working standard used in field conditions to ensure traceability of the subordinate measurements to the SI and leaves no ambiguity in its meaning. Thus, the recommended changes to HB 44 align that document with the HB 130, removing ambiguity and adding clarity to the use of Field Standards for device testing.

2018 NCWM Interim Meeting: The Committee heard comments on the proposal (then identified as Block 4) and agreed to recommend that the entire block of items move forward as Developing. The Committee also concluded that all of the items listed at that time as Block 5 items, as well as LPG-4, and MFM-2 are related to the Block 4 items due to terminology.

The Committee received written comments on all items in Block 4 and Block 5, as well as LPG-4 and MFM-2 emphasizing the need for there to be more study and discussion of the issues to assess the ramifications of all the proposed changes. The Committee also received written comments from the SMA that it looks forward to further information on these items and stating that it is important to be consistent in our use of terms across multiple sections of Handbook 44. The Committee agreed to carryover this group of items on its 2019 agenda to allow for further discussion and development of these proposals.

2019 NCWM Interim Meeting: The S&T Committee decided to combine the items on the agenda dealing with the issue of transfer standard (including items already combined into blocks) into one block. Block 1 (New) of the Interim Meeting report now includes Gen-3, Block 1 (original items from the 2019 interim agenda that appeared under Block 1), Block 2, LPG-3 and MFM-5, which were all separate items and blocks of items on the S&T Committee’s 2019 Interim Meeting agenda (NCWM Publication 15). Agenda items Gen-3, Block 1, Block 2, LPG-3 and MFM-5 are listed separately on the Interim agenda with a note added beneath each individual item referring the reader to the New B1 items. All items under this New B1 have retained the same numbering system for ease in referring to the appendix for discussion on each item.

2019 NCWM Annual Meeting: The Committee heard from Mr. Brett Gurney (NCWM Chairman) regarding the formation of a Task Group assigned to further develop this block proposal. The TG is charged with providing definitions for various types of standards (transfer, field, reference, etc.) as well as the criteria to be met by these types of standards. The completion date given to the TG is July 2021. The Committee agreed to the Assigned status for this block of items and looks forward to hearing updates from the TG.

2020 NCWM Annual Meeting: Due to the 2020 Covid-19 pandemic, this meeting was adjourned to January 2021, at which time it was held as a virtual meeting. Due to constraint of time, only those items designated as 2020 Voting Items were addressed. All other items were addressed in the subsequent 2021 NCWM Interim Meeting.

2020 NCWM Interim Meeting: The S&T Committee heard from Mr. Jason Glass (KY) Chair of the task group assigned to further develop Block 1 items. Mr. Glass reported that the task group met prior to the interim meeting and has begun discussion of the items under Block 1. Mr. Glass stated that bi-weekly teleconference meetings were scheduled and that the group was optimistic but had significant work to accomplish.

Mr. Russ Vires, SMA, supports the Scale item, SCL 18.1, in this block, Mr. Dimitri Karimov (Meter Manufacturers Association) supports the Task Group activities, Tina Butcher was encouraged with the progress on terminology and provided an update on the Mass Flow Meter testing reporting that field testing was conducted October 28 to November 1, 2019 and that State and Industry participation included Colorado, Florida, Oregon, Emerson and Tulsa Gas Technology.

Mr. Kurt Floren (L.A. County, CA) concerns with GEN-19.1. regarding the definition of “Standard, Field” and its reference to “stable” standards and how long a standard is expected to be stable, which is typically 1-year, for which he believes should be longer. Mr. Floren also questioned the statement in the definition “tested over a range of environmental and operational conditions that the measuring devices is used...” Mr. Floren noted that he is unsure if all laboratories will have the capabilities to test over this wide range of conditions. Mr. Floren also expressed concerns with the definition “Standard, Transfer” citing that this standard may not meet the fundamental considerations requirement for standards over a long period of time or wide range of environmental conditions.

Mr. Steve Harrington (OR) echoed Mr. Floren’s comments. Mr. Jason Glass responded that these are concerns of the task group and these issues will be discussed and considered as the task group develops these items.

During the Committee's work session, the committee agreed that this item should remain an Assigned item.

2020 NCWM Annual Meeting: Due to the 2020 Covid-19 pandemic, this meeting was adjourned to January 2021, at which time it was held as a virtual meeting. Due to constraint of time, only those items designated as 2020 Voting Items were addressed. All other items were addressed in the subsequent 2021 NCWM Interim Meeting.

2021 NCWM Interim Meeting: The Committee heard from Mr. Jason Glass (Kentucky and chair of the Field Standard task group) who provided an update on the task group activities. Mr. Glass reported that the field standard task group is following the activities of the NIST Master Meter Project and that the task group reviewed API specifications for use of master meters as a standard and a test protocol that will be used to ensure uniformity in collecting data on master meters used as field standards. He also reported that the task group does not have a recommendation for this item. Mr. Glass also reported that he would be stepping down as the task group chair. Mr. Mike Keilty (Endress+Hauser AG) thanked Mr. Glass and the task group for their work and requested that Block 1, LPG-15.1, N.3. and Block 1 MFM-15.1, N.3 be removed from Block 1 items and to allow those items to move forward separate from the other block 1 items. Mr. Keilty stated that similar language was added to the Hydrogen code and that the proposed language in LPG-15.1 N.3. and MFM-15.1, N.3 will allow for the recognition of master meters as field standards. Mr. Henry Oppermann (WM-consulting), stated that data is needed to ensure that master meters can be used over a range of conditions. Mr. Robert Murnane (Seraphin) stated that jurisdictions have the ability to use meters and that Block 1 LPG-15.1, N.3 and Block 1 MM-15.1, N.3 should remain in block 1 until data is available to support the use of master meters as a standard. Mr. Keilty mentioned that there has been useful dialog regarding master meters in the task group, but that he is concerned that the task group is not close to making a decision and he expressed concerns with the task groups focus on the NIST Master Meter Project. Tina Butcher (NIST, OWM) provided an update on the NIST Master Meter Project and noted that States have the regulatory powers to accept or reject a standard. She also mentioned that NIST is working with States to collect data needed to assess master meters and preliminary testing was conducted and data was collected on CNG at Tulsa Gas Technology's facility in fall 2019. Diane Lee (NIST, OWM) noted that NIST OWM feels that it is premature to add more language to the Handbook 44 on master meters without data to support its use.

During the committee's work session, the committee agreed to keeps all items in Block 1 and that this item should remain with an Assigned status

Regional Association Comments:

WWMA 2019 Annual Meeting: Mr. Russ Vires (SMA) stated that SMA supports the proposal as it related to the items addressing scale requirements and would also recommend the use of uniform terminology in the proposed changes.

Mr. Kurt Floren (Los Angeles County, California) stated that this issue should be addressed from a metrologist perspective. Mr. Floren also stated that if there was a challenge to whether mass field standards are tested under all possible environmental conditions there may be no substantial evidence that this procedure is followed. Committee agrees to recommend that the Assigned status is maintained and looks forward to the work in progress by the TG.

SWMA 2019 Annual Meeting: Mr. Russ Vires (SMA) stated that he supports this item as it pertains to SCL 18.1, ABW 18.1, and ABS 18.1. Ms. Diane Lee (NIST OWM) provided guidance based on last year's comments. This item is already assigned to a task group.

NEWMA 2019 Interim Meeting: The Committee and body agree that this item should be assigned. During open hearings, Mr. John McGuire (NJ) asked if this had been assigned yet. Mr. Dick Suiter (Richard Suiter Consulting) indicated that it has been marked as assigned to a TG and the TG is gathering members in order to be working by January.

2020 Regional Meetings of the WWMA, NEWMA, and SWMA: These regions adhered to a condensed agenda due to the Covid pandemic and did not consider this item.

CWMA 2020 Interim Meeting: G. Diane Lee (NIST OWM), a member of the Field Standards Task Group gave an update of the progress of this item to the S&T committee. We look forward to the work of the task group.

Additional letters, presentations and data may have been part of the Committee's consideration. Please refer to <https://www.ncwm.com/publication-16> to review these documents.

Comments and justification for the regional recommendation to NCWM: *(This will appear in NCWM reports)*

Diane Lee (NIST OWM) reported that testing with NIST master meters is underway. CNG meters are being tested in Colorado. The LPG master meter is to set to begin being used shortly. There are two separate task groups working on this project. The NCWM Field Standards Task Group is looking for a new chairman. Russ Vires (SMA) stated that the SMA supports continued efforts on this proposal. Doug Musick (KS) support the items moving forward but more information is needed concerning their use. Bob Murnane (Serphin Test Measures) stated that not much more can be done without data to show that meters can be used as a standard. Seraphin stated that there is a paper discussing direction for the task group. Tina Butcher (NIST OWM) stated that testing for the different types of the master meters would occur simultaneously to speed up the data collection and analysis of the data. Charlie Stutesman (KS) asked if there was a date for conclusion of the task group activities and expressed the need to stay on top of this item. He suggested that there may be a need to set a sunset date for the activities of the task group. Loren Minnich (KS) reported that NCWM set an original goal of July 2021 to complete the mission but it is not a deadline. Tina Butcher reported on what the master meters group is trying to achieve. Tina reminded the group that the Fundamental Considerations allows States to use master meters. OWM is assisting states with determining that these "master meters" would be viable for use as a field standard Adding something to the Fundamental Considerations to clarify that states can use them may be helpful. NIST is currently focusing on the Coriolis meter but what will come out of the study will be protocols that States can apply to other meter technologies.

The CWMA S&T Committee recommends that this Item Block remain Assigned.

BLOCK 5 ITEMS (B5) CATEGORY 3 METHODS OF SEALING

B5: LMD-20.1 W Table S.2.2. Categories of Device and Methods of Sealing.

Source:

Wayne Fueling Systems, LLC

Purpose:

Allow for an electronic log in lieu of a printed copy for a category 3 seal on an LMD.

Item Under Consideration:

Amend Handbook 44 Liquid Measuring Device Code as follows:

| <i>Table S.2.2.</i> | |
|--|--|
| <i>Categories of Device and Methods of Sealing</i> | |
| <i>Categories of Device</i> | <i>Methods of Sealing</i> |
| <i>Category 1: No remote configuration capability.</i> | <i>Seal by physical seal or two event counters: one for calibration parameters and one for configuration parameters.</i> |

| | |
|---|--|
| <p>Category 2: Remote configuration capability, but access is controlled by physical hardware.</p> <p>The device shall clearly indicate that it is in the remote configuration mode and record such message if capable of printing in this mode or shall not operate while in this mode.</p> | <p>[The hardware enabling access for remote communication must be on-site. The hardware must be sealed using a physical seal or an event counter for calibration parameters and an event counter for configuration parameters. The event counters may be located either at the individual measuring device or at the system controller; however, an adequate number of counters must be provided to monitor the calibration and configuration parameters of the individual devices at a location. If the counters are located in the system controller rather than at the individual device, means must be provided to generate a hard copy of the information through an on-site device.]*</p> <p>[*Nonretroactive as of January 1, 1996]</p> |
| <p>Category 3: Remote configuration capability access may be unlimited or controlled through a software switch (e.g., password).</p> <p>[Nonretroactive as of January 1, 1995]</p> <p>The device shall clearly indicate that it is in the remote configuration mode and record such message if capable of printing in this mode or shall not operate while in this mode.</p> <p>[Nonretroactive as of January 1, 2001]</p> | <p>An event logger is required in the device; it must include an event counter (000 to 999), the parameter ID, the date and time of the change, and the new value of the parameter. A printed copy of the information must be available on demand through the device or through another on-site device. The information may also be available electronically. <u>The information must be available on demand through the device or through another on-site device either in printed or electronic format.</u> The event logger shall have a capacity to retain records equal to 10 times the number of sealable parameters in the device, but not more than 1000 records are required. (Note: Does not require 1000 changes to be stored for each parameter.)</p> |

[Nonretroactive as of January 1, 1995]

(Table Added 1993) (Amended 1995, 1998, 1999, 2006, and 2015)

Background/Discussion:

This item has been assigned to the submitter for further development. For more information or to provide comment, please contact:

Mr. Randy Moses
 Wayne Fueling Systems
 215-257-2759, randy.moses@doverfs.com

The amount of information required for a category 3 log is extensive (5 items x 1000 events). That is a lot of printing, especially using a standard receipt printer. With today’s technology leaning towards the ability to perform remote downloads and configurations, we need a practical approach that allows this technology to move forward while still providing the means to document changes to sealable parameters that have taken place in the device. In most cases, the printer inside of the dispenser is not directly connected to the dispenser electronics and thus printing on the internal printer is at best difficult, and in most cases, not possible. The ability to provide an electronic file in lieu of a printed copy can also enhance the ability to organize the information contained in the log to make it easier to present to the official. The exact format and electronic transportation method are open to discussion.

The submitter noted that Officials do not carry devices capable of reading an electronic file or are not permitted to access such files.

B5: LMD-21.1 D Table S.2.2. Categories of Device and Method of Sealing

Source:
Gilbarco Inc.

Purpose:
To modify Category 3 requirements under Methods of Sealing to allow electronic copy of event logger for liquid measuring devices. To enhance or have alternate wording to existing Item LMD-20.1 under review for this item.

Item Under Consideration:
Amend Handbook 44, Liquid Measuring Devices Code as follows:

| <i>Table S.2.2.</i> | |
|---|---|
| <i>Categories of Device and Methods of Sealing</i> | |
| <i>Categories of Device</i> | <i>Methods of Sealing</i> |
| <i>Category 1: No remote configuration capability.</i> | <i>Seal by physical seal or two event counters: one for calibration parameters and one for configuration parameters.</i> |
| <i>Category 2: Remote configuration capability, but access is controlled by physical hardware.</i> <i>The device shall clearly indicate that it is in the remote configuration mode and record such message if capable of printing in this mode or shall not operate while in this mode.</i> | <i>[The hardware enabling access for remote communication must be on-site. The hardware must be sealed using a physical seal or an event counter for calibration parameters and an event counter for configuration parameters. The event counters may be located either at the individual measuring device or at the system controller; however, an adequate number of counters must be provided to monitor the calibration and configuration parameters of the individual devices at a location. If the counters are located in the system controller rather than at the individual device, means must be provided to generate a hard copy of the information through an on-site device.]*</i> <i>[*Nonretroactive as of January 1, 1996]</i> |

| | |
|---|--|
| <p>Category 3: Remote configuration capability access may be unlimited or controlled through a software switch (e.g., password).</p> <p><i>[Nonretroactive as of January 1, 1995]</i></p> <p>The device shall clearly indicate that it is in the remote configuration mode and record such message if capable of printing in this mode or shall not operate while in this mode.</p> <p><i>[Nonretroactive as of January 1, 2001]</i></p> | <p>An event logger is required in the device; it must include an event counter (000 to 999), the parameter ID, the date and time of the change, and the new value of the parameter. A printed copy of the information must be available on demand through the device or through another on-site device. The information may also be available electronically. <u>The event logger information shall be available at the time of inspection either as a printed copy or in electronic format. The information may be printed by the device, printed by another on site device, or transmitted electronically.</u> The event logger shall have a capacity to retain records equal to 10 times the number of sealable parameters in the device, but not more than 1000 records are required. (Note: Does not require 1000 changes to be stored for each parameter.)</p> |
|---|--|

[Nonretroactive as of January 1, 1995]

(Table Added 1993) (Amended 1995, 1998, 1999, 2006, and 2015)

Background/Discussion:

Current requirement is that category 3 device must have printed copy made available on site for the event logger information. Category 3 devices are fully connected electronic devices here in the modern age and thus we need to move away from the archaic requirement of only allowing a paper copy for this item. The industry fully supports this change. LMD’s have many types of regulatory events that accumulate in the event logger: blend ratio changes, calibration changes for the meters, SW downloads are examples. Often our only available print option is through the device receipt printer. With its tiny width of receipt paper the event log for an older liquid measuring device will be several feet long and have text that wraps and is difficult to read. Allowing an electronic copy will be more convenient, easily read, and easily saved/retained/shareable.

Wayne Fueling Systems, LLC has a current proposal, Item LMD-20.1 for this item and in discussion with him he has been very supportive of me providing alternate wording above for consideration, or possibly to use in place of his proposal. Hopefully we can hear from Wayne on this in the upcoming meetings. Also, I am aware of the Electric vehicle charger industry is working on this item to propose allow electronic copy as well.

The submitter requested voting status for this item in 2021.

2020 NCWM Interim Meeting: The Committee heard from Mr. Brent Price (Gilbarco) who recommended a voting or developing status for this item and offered to work with the submitter, Wayne Fueling Systems, LLC and has some alternative language that he would like to go through the regionals for input. Mr. Price further explained that new category 3 devices are coming to market that have audit logs that can be printed but the font is very small. Mr. Tim Chesser (AR) responded that Arkansas would require an electronic log if it is an option and that the proposal needs additional work concerning the log information and agrees with the efforts of Gilbarco and Wayne.

Mr. Dmitri Karimov (MMA) noted that he supports the electronic log option proposed by Wayne and Gilbarco which would allow for flexibility. Ms. Tina Butcher (NIST OWM) supported the proposal for electronic logs but noted that the proposal needs more development. Among other issues addressed, Ms. Butcher noted that NIST OWM believes it is important to ensure that the inspector can access the event log at the time of inspection. Ms. Butcher also noted that additional comments are in the NIST OWM analysis. Mr. Steve Harrington (OR) agreed with both comments from Ms. Butcher, Mr. Tim Chesser (AR) and that opening cabinets on dispensers is becoming more problematic and could see that electronic audit trail logs could help to resolve this issue. Mr. Jim Pettinato (Technip FMC, Chair of the Software Sector) noted that the Software Sector agrees that electronic logs are preferred and suggested in addition, that a user requirement may also be needed to address concerns he heard from inspectors not being able to get the information they need. Mr. Jim Willis (NY) reported that he supports both Ms. Butcher and Mr. Chesser’s comments and supports further development of this item. Mr. Richard Suiter (Richard Suiter Consulting) stated that he is currently working with a software company that is building a two-level security system that may offer solutions

to resolve any opposition to this proposal. Mr. Kevin Schnepf (CA) supports electronic logs and supports this as a developing item.

During the Committee’s work session, the committee agreed that this item should be given a Developing status. The submitter should focus on how the log will be formatted if not printed. The format should be such that there are no barriers to accessing the information in the log.

2020 NCWM Annual Meeting: Due to the 2020 Covid-19 pandemic, this meeting was adjourned to January 2021, at which time it was held as a virtual meeting. Due to constraint of time, only those items designated as 2020 Voting Items were addressed. All other items were addressed in the subsequent 2021 NCWM Interim Meeting.

2021 NCWM Interim Meeting: The Committee heard from Mr. Randy Moss (Wayne Fueling Systems, LLC) the submitter of LMD-20.1, who supports the option of electronic logs for Category 3 sealing requirements. The committee also heard from a representative from Gilbarco who also supports electronic logs. Kevin Schnepf (CA) supported the development of this item. Mr. Josh Nelson (OR) asked if there will be one proposal and there was support for moving forward with Item LMD-21.1. Mr. Randy Moss (Wayne Fueling Systems, LLC), agreed to withdraw item number LMD-20.1. Both submitters of items LMD-20.1 and LMD-21.1 will work together to further develop item LMD-21.1.

During the 2021 NCWM Interim Meeting work session, the Committee agreed to withdraw LMD-20.1 and agreed that the submitter of LMD-20.1, Wayne Fueling Systems, LLC, will work with the Submitter of LMD-21.1, Gilbarco, to develop one proposal to allow electronic logs for Category 3 sealing requirements. The committee agreed on a Developing status for LMD-21.1

Regional Associations’ Comments:

WWMA 2020 Annual Meeting: Mr. Brent Price (Gilbarco) commented this is a little different than other proposals. Gas pumps have limited printing capabilities on receipts so they would like the option for electronic printing. Suggests combining into one proposal with Wayne Pump. Steven Harrington (Oregon) commented he was concerned about how this will affect device testing efficiency by adding additional testing steps in the field. He is also concerned about time and structure of how this information is received in the field. Committee recommends this to be assigned developing status. The Committee recommends that the submitter work with other stakeholders and vets this through the other regions for further development.

SWMA 2020 Annual Meeting: During Open Hearings the Committee heard from Mr. Brent Price (Gilbarco), the submitter, who stated that he wants to have the option of an Electronic Event Log, and for the item to be considered as fully developed. The Committee also heard from Tina Butcher (OWM) who stated she would like to have consistent language in the Handbook for LMD, EVSE, and Taximeters. The Committee notes that it prefers the language in this item rather than a similar item submitted by Wayne last year.

After considering this item the Committee recommends the item given Voting status.

NEWMA 2020 Interim Meeting: The Committee agrees with the bodies recommendation that this item move forward with a Voting designation. During open hearings, the Committee heard from the submitter that the intent was not to have multiple proposals, but that there was support from the submitter of the developing, grouped item that this item move forward. There was no discussion heard against this proposal. There is another item proposed EVF 21.4 that has a similar purpose and should have matching language.

CWMA 2020 Interim Meeting: Ms. G. Diane Lee (NIST OWM) advised the S&T Committee that the developers of both items are working together to present one item in the future. We recommend this item remain Developing and look forward to collaborative results to come.

Additional letters, presentation and data may have been submitted for consideration with this item. Please refer to <https://www.ncwm.com/publication-16> to review these documents.

| |
|--|
| CWMA Report |
| Comments and justification for the regional recommendation to NCWM: <i>(This will appear in NCWM reports)</i> |

Diane Lee (NIST OWM) provided background and technical information on this item. OWM believes this should move forward as a developing item.
The CWMA S&T Committee recommends that Item B5: LMD-21.1 remain Developing.

VTM – VEHICLE TANK METERS

VTM-18.1 D S.3.1 Diversion of Measured Liquid and S.3.1.1. Means for Clearing the Discharge Hose and UR.2.6. Clearing the Discharge on a multiple-product, single discharge hose.

NOTE: At the 2020 Interim Meeting the Committee agreed to combine both VTM-18.1 and VTM-20.1. Both items are now one item under VTM-18.1

Source:

New York and NIST OWM (Carryover from 2018, VTM 1-B) and Murray Equipment, Inc., Total Control Systems

Purpose:

Provide specifications and user requirements for manifold flush systems on a multiple-product, single-discharge hose. Recognize that there is a balance between a mechanism that provides an important safety benefit but also, if used incorrectly, facilitates fraud. Ensure that VTM owners understand their responsibilities when installing such a system and ensure uniformity in enforcement throughout the country and clarify the paragraph to protect vehicle motor fuel quality, retain safe operating procedures when handling vehicle motor fuels, and to prevent fraud during delivery of vehicle motor fuels from vehicle tank meters.

Item Under Consideration:

Amend Handbook 44, Vehicle-Tank Meters Code as follows:

S.3.1. Diversion of Measured Liquid. – No means shall be provided by which any measured liquid can be diverted from the measuring chamber of the meter or the discharge line thereof. However, two or more delivery outlets may be installed if means are provided to ensure that:

- (a) liquid can flow from only one such outlet at one time; and
- (b) the direction of flow for which the mechanism may be set at any time is definitely and conspicuously indicated.

This paragraph does not apply to the following:

- (1) Equipment used exclusively for fueling aircraft.
- (2) Multiple-product, single-discharge hose metering systems that are equipped with systems designed to flush the discharge hose, provided the flushing system complies with the provisions of paragraph S.3.1.1. Means for Clearing the Discharge Hose, **Multiple-Product, Single-Discharge Hose Metering Systems.**

(Amended 2018 **and 20XX**)

S.3.1.1. Means for Clearing the Discharge Hose, Multiple-Product, Single-Discharge Hose Metering Systems, - Multiple-product, single-discharge hose Metering systems may be equipped with systems specifically designed to facilitate clearing of the discharge hose prior to delivery to avoid product contamination. In such systems, a valve to temporarily divert product from the measuring chamber of the meter to a storage tank, shall be installed only if all the following are met:

- (a) the discharge hose remains of the wet-hose type;
- (b) the valve and associated piping are approved by the weights and measures authority having jurisdiction over the device prior to commercial use;

- (c) the valve is permanently marked with its purpose (e.g. flush valve);
- (d) the valve is installed in a conspicuous manner and as far from the hose reel as practical;
- (e) the system clearly and automatically indicates the direction of product flow during operation of the flush system; and
- (f) clear means, such as an indicator light or audible alarm, is used to identify when the valve is in use on both quantity indications and any associated recorded representations (e.g., using such terms as “flushing mode” or “not for commercial use”):
[nonretroactive as of January 1, 2024.]
- (g) effective, automatic means shall be provided to prevent passage of liquid through any such flush system during normal operation of the measuring system; and
[nonretroactive as of January 1, 2024.]
- (h) no hoses or piping are connected to the inlet when it is not in use.

(Added 2018)(Amended 20XX)

UR.2.6. Clearing the Discharge Hose.

UR.2.6.1. Clearing the Discharge Hose, General. – A manifold flush or similar system designed to accommodate the flushing of product on single-hose, multiple-product systems is not to be used during a commercial transaction. The following restrictions apply:

- a) The inlet valves for the system are not to be connected to any hose or piping (dust covers are permitted) when not in use.
- b) When the flushing system is in operation, the discharge hose is only to be connected to the port for the product type being flushed from the discharge line.
- c) Following the flushing process, indications and recording elements must be reset to zero prior to beginning a commercial delivery.

(Added 20XX)

UR.2.6.2. Records. Whenever, prior to delivery, a different product is pumped through the discharge hose to avoid contamination, a record including the date, time, original product, new product, and gallons pumped shall be maintained. These records shall be kept for a period of 12 months and available for inspection by the weights and measures authority.

(Added 2018)

Background/Discussion:

This item has been assigned to the submitter for further development. For more information or to provide comment, please contact:

Mr. Jim Willis
New York Department of Agriculture and Markets
518-485-8377, james.willis@agriculture.ny.gov

This item was one of two separate parts of VTM-1 (previously VTM-1A and VTM-1B) considered by the Committee at the 2018 NCWM Annual Meeting. The item voted on at the 2018 Annual Meeting, VTM-1A was adopted and VTM-1B was assigned an Informational status and carried-over to the next cycle.

Manifold flush systems are typically used on VTM's with multiple compartments, delivering multiple products through a single hose. The purpose of the system is to allow the driver a means of clearing the hose of product prior to delivery (e.g., clearing

the hose of diesel fuel before delivering clear kerosene). These types of systems are often marketed as a safety feature in that it eliminates the need for the driver to climb on top of the truck to clear the hose. Such systems are also useful in helping avoid cross-contamination. Typically, the driver attaches the nozzle to the manifold and pumps product back into the supply tank via the manifold until the previous product is flushed from the hose. There is often a sight gauge which allows the driver to tell when the product is flushed.

The obvious concern is that this makes it very easy for the driver to circulate product through the meter prior to delivery, which goes against S.3.1. It should be noted that it also goes against S.3.1. when the driver climbs on top of the tanker and clears the hose. The submitter has voiced concerns involving the safety of this practice noting that the operator could be subject to falls from the tanker. The distance between the flush system and the hose reel is also a factor in how easy it is for the driver to facilitate fraud.

Manifold flush systems are available from OEMs and can be found in various catalogs. Looking on multiple websites, these systems are being installed across the country and for some manufacturers seem to be standard equipment for new trucks. The submitter of VTM-1 has also seen these systems installed on trucks that are for sale where the seller notes the system as a selling point. He can foresee these systems being mandated in the future as a safety requirement and would like W&Ms to have a clear policy before that happens.

Another concern is with systems fabricated onsite. These systems are often difficult to distinguish and installed in an inconspicuous manner. While the submitter of VTM-1 has ordered many of these systems out-of-service until repaired, it can be frustrating for the owner because the truck was used in another state for years and approved by weights and measures jurisdiction in the other state. This lack of uniformity is problematic for both officials and private industry.

At the 2018 NCWM Annual Meeting, the Committee heard comments from OWM that this item needed additional work to address concerns that had been identified in OWM's 2018 Interim Meeting (and earlier) analyses. While there are clear benefits to improving safety when flushing hoses, OWM and others have noted these systems can facilitate fraud without appropriate safeguards in place. OWM noted the language in the Item Under Consideration in the Committee's 2018 Interim Report would:

1. provide an (unintentional) exemption to the provisions for "diversion of product" for *all* single meter, multiple product, multiple compartment systems;
2. would (unintentionally) require all such systems to be equipped with a manifold flush system;
3. fail to include requirements for the system to clearly indicate (on both display and recorded representations) when the flush system is in operation; and
4. fail to include limitations on how the user is permitted to appropriately use these systems.

In discussing the changes OWM felt were needed prior to the Annual Meeting, the submitter and OWM agreed that some of OWM's proposed changes would be considered editorial and others technical in nature. Since other than editorial changes could affect the Voting status of the item, OWM offered the following two courses of action for the Committee to consider:

1. Downgrade the item to Informational to allow time to address all the changes that are needed; or
2. Split the item into two parts to allow the portion of the item needing only editorial changes to move forward for vote; and carryover the remaining portion to allow time for it to be further developed and considered during the next NCWM cycle.

Rather than hold up the entire item to be considered in the next Conference cycle, the submitter requested the item be split into two parts to allow the completed portion, including the editorial changes, to move forward for vote.

2019 NCWM Interim Meeting: The Committee heard comments to Agenda Item VTM-1 as well as position statements from MMA that they objected to manifold flush systems. NIST OWM provided an analysis to the Committee prior to the Interim Meeting. The comments heard during the open hearing and/or received prior to the Interim meeting are summarized below:

Mr. Hal Prince (Florida) stated that it was missing any inclusion for limitation of use, such as when delivering multiple products. He suggested that the Committee consider language forwarded by the SWMA in its 2018 Annual Report. Mr. Prince also suggested that the item be kept developmental. Mr. Dan Murray, (Murray Equipment, Total Controls System) stated that Manifold Flush Systems were a big problem in Europe where they are permitted. Mr. Murray suggested these systems could facilitate fraud and NTEP should carefully consider this before granting approval. These systems should also be sealed. Mr. Murray's opinion was that the item should be withdrawn. Mr. Dmitri Karimov speaking on behalf of Meter Manufacturers Association, stated that MMA objected to manifold flush systems.

NIST OWM agreed with the WWMA and the CWMA that this item is fully developed and agreed with assigning it a voting status. OWM provided the following review of the operation of the equipment, proposed changes, and additional points to consider:

- At the 2018 NCWM Annual Meeting the Conference voted to allow an exemption to S.3.1. for Manifold Flush Systems, which is currently in the 2019 NIST HB 44 VTM code.
- S.3.1. states “no means” shall be provided to divert liquid from the measuring chamber of the meter or the discharge line.
- A manifold flush system allows liquid to be diverted from the discharge line on single hose multi-compartment VTMs so that liquid of one product is not mixed with liquid of another in the discharge line.
- Without a manifold flush system, the operator must manually return the product to the correct compartment to clear the discharge line before using another product.
- There are safety hazards with manually returning the product to storage (operator climbing on top of tank and lifting hose to return the product. There are also safety concerns when not properly clearing the discharge lines prior to delivering a different product and because of these safety concerns it was reported that more of these systems will likely be installed on single hose multicompartments trucks.
- Although safety is a high priority, the “means” used to return product back to storage is not as visible and makes facilitation of fraud a high possibility.
- The additional changes proposed are intended to ensure such systems are designed such that they do not facilitate fraud; help ensure owners understand their responsibilities when installing such a system; and ensure uniformity in enforcement throughout the country.
- The changes reflect the suggested language from OWM's previous analysis and incorporate comments received from the MMA and others during the 2018 Annual meeting.

Non-retroactive dates may need to be added to allow time for manufacturers of flush systems to incorporate the safeguards into their systems. During the committee's work session, the Committee considered the comments received during the Interim Meeting open hearings and recommended a voting status for this item.

2019 NCWM Annual Meeting: The Committee supported amendments proposed to subparts (f) and (g) based upon statements from the submitter (NY) indicating that manufacturers of manifold flush systems will need additional time to incorporate the safeguards into their systems. The Committee also agreed to place the item on the voting consent calendar as amended, and as shown in the Item Under Consideration.

During the open hearing sessions, the Committee heard comments from NIST OWM's Mrs. Tina Butcher offering a revision of S.3.1.1.(f), suggesting this portion be split into separate bullet points. Also heard were comments from Mr. Jim Willis (NY) in support of NIST OWM's suggestion and his recommendation for making this a nonretroactive requirement to allow manufacturers time to accommodate the necessary changes.

During the voting session, it was requested this item be removed from the voting consent calendar and voted on separately. The item failed to receive enough votes for adoption and was therefore returned to the Committee.

2020 NCWM Interim Meeting: The Committee heard from Mrs. Butcher (NIST OWM) who recommended that VTM-18.1 and VTM-20.1 be combined because both items address manifold flush systems but VTM 18-1 does not restrict the use of the system to certain products and VTM 20-1 restricts the use of the system to home heating fuel. Mrs. Butcher recommended that the combined item be given a developing status to address the design and use of these systems adequately. Mrs. Butcher also recommended improvements to VTM 18-1 and VTM 20-1.

Mr. Dmitri Karimov (MMA) agreed with the language proposed in VTM 18-1 and acknowledged that there is value in the alternative proposal VTM-20.1 and supports combining both proposals into one. Mr. Hal Prince (FL) also agreed that Item VTM-18.1 and VTM-20.1 be combined and given a developing status. Mr. Prince expressed a willingness to work with submitters to further develop the items and noted that he has concerns with cross-contamination caused by these systems. Mr. Jim Willis agreed with Mrs. Butcher's statements. Mr. Karimov recommended including more categories for types of fuels in the proposal is important such as flammable, explosive, etc. Mr. John Hathaway (Murray Equipment) submitter of VTM-20.1 expressed interest in working together with the submitters of VTM-18.1.

During the Committee's work session, the committee agreed that this item, VTM-18.1 should be combined with VTM-20.1 and be given a developing status to allow the submitters of both items to work together towards resolving the conflicts in these two items.

2020 NCWM Annual Meeting: Due to the 2020 Covid-19 pandemic, this meeting was adjourned to January 2021, at which time it was held as a virtual meeting. Due to constraint of time, only those items designated as 2020 Voting Items were addressed. All other items were addressed in the subsequent 2021 NCWM Interim Meeting.

2021 NCWM Interim Meeting: The Committee heard from Mr. Mike Smith (New York) who supports VTM 18.1 as a Developing item and he agreed to work with the other submitters of this item on paragraphs S.3.1.1. (f) and (g) and to address contamination. Mr. Hal Prince (FL) supports a Developing status for VTM-18.1 and noted that with VTM-18.1 there will be issues with fuel contamination. The concern raised in previous discussions was that if these manifold systems are used with multi-product, single discharge hose dispensers for the delivery of both motor fuels and home heating fuels, a small amount of home heating fuel mixed with a motor fuel could be problematic. It was also noted that these fuels could get contaminated repeatedly whenever there is a change from one fuel to another and that there is also the safety issue of flashing when mixing a gasoline with diesel or kerosene. Ms. Diane Lee report that VTM-18.1 and VTM-20.1 conflict. VTM-20.1 restricts the use of these systems to be used with only home heating fuels. Dmitri Karimov (MMA) noted if VTM-18.1 is adopted then VTM-20.1 would not be required. Mr. Charles Stutesman, (KS) was not sure if VTM-18-1 and VTM-20-1 were being discussed together and it was pointed out that it was agreed that they be combined at the 2020 interim meeting. Mr. John Hathaway (Total Control Systems) agreed with a Developing status for this item and noted that the changes to Paragraphs (f) and (g) would help to address some of the issues that were raised.

During the Committee's work session, the committee agreed to a Developing status for VTM-18.1 and to Withdraw VTM-20.1. The committee also stated that any concerns with contamination and safety should also be addressed.

Regional Association Comments:

WWMA 2019 Annual Meeting: There were no comments during open hearings on this item.

The Committee agrees that the item has merit and this item failed to be adopted when voted upon during the 2019 NCWM Annual Meeting. The Committee agreed that the item should be given a Developing status and that the submitters work together to further develop the proposal considering the statements made by NIST OWM during the 2019 NCWM Annual Meeting open hearing and the amendments that were presented at that time.

SWMA 2019 Annual Meeting: Mr. Hal Prince (Florida) stated that this item muddies the waters and will cause the unacceptable cross contamination of engine fuels.

The Committee recommends that this item move forward as a Developing Item, if the developers of VTM 18.1 and VTM 20.1 can combine their language to include an exception specifically for "Engine Fuels."

NEWMA 2019 Interim Meeting: The Committee and the body agree that this item be moved to voting status, but with some changes to language. The Committee believes that the item in its current form will place undue burden on the industry as it already uses manifold flush systems and retrofitting them will be costly. The following language is proposed:

- (i) clear means, such as an indicator light or audible alarm, is used to identify when the valve is in use *on both quantity indications and any associated recorded representations (e.g., using such terms as “flushing mode” or “not for commercial use”*;

[nonretroactive as of January 1, 2022 2024 to become retroactive January 1, 2025]

- (j) *effective, automatic means shall be provided to prevent passage of liquid through any such flush system during normal operation of the measuring system; and*

[nonretroactive as of January 1, 2022 2024 to become retroactive January 1, 2025]

During open hearings, submitters Mr. Jim Willis (New York) and Mr. Steve Timar (New York) recommended removing retroactive dates and extend non-retroactive to 2024.

2020 Regional Meetings of the WWMA, NEWMA, and SWMA: These regions adhered to a condensed agenda due to the Covid pandemic and did not consider this item.

CWMA 2020 Interim Meeting: Tina Butcher (NIST OWM) requested that the committee recommend this item remain a developing item. CWMA recommended a Developing status for this item.

Additional letters, presentations and data may have been part of the Committee’s consideration. Please refer to <https://www.ncwm.com/publication-16> to review these documents.

| CWMA Report |
|--|
| Comments and justification for the regional recommendation to NCWM: <i>(This will appear in NCWM reports)</i> |
| No comments heard on this item. The CWMA S&T Committee recommends this item remain Developing. |

VTM-20.1 W S.3.1. Diversion of Measured Liquid.

NOTE: At the 2020 NCWM Interim Meeting the Committee agreed to combine VTM-20.1 with VTM-18.1. This item is now included with Agenda Item VTM-18.1. See the Appendix portion of this report for background information on this item.

NOTE: At the 2021 NCWM Interim Meeting the Committee agreed to Withdraw this item which the Committee combined with VTM-18.1 at the 2020 NCWM interim Meeting. See additional comments under VTM-18-1.

| CWMA Report |
|--|
| Comments and justification for the regional recommendation to NCWM: <i>(This will appear in NCWM reports)</i> |
| No comments on withdrawn items. |

VTM-20.2 V Table T.2. Tolerances for Vehicle Mounted Milk Meters.

Source:
POUL TARP A/S

Purpose:
Change tolerances to accommodate more efficient milk-metering systems.

Item Under Consideration:
Amend Handbook 44, Vehicle-Tank Meters Code as follows:

| Table 2. Tolerances for Vehicle-Mounted Milk Meters | | |
|--|---|---|
| Indication (gallons) | Maintenance Tolerance (gallons) | Acceptance Tolerance (gallons) |
| 100 Complete Measuring System | 0.5 0.5% | 0.3 0.5% |
| 200 Meter Only | 0.7 0.3% | 0.4 0.3% |
| 300 | 0.9 | 0.5 |
| 400 | 1.1 | 0.6 |
| 500 | 1.3 | 0.7 |
| Over 500 | Add 0.002 gallon per indicated gallon over 500 | Add 0.001 gallon per indicated gallon over 500 |

(Added 1989, Amended 20XX)

Background/Discussion:

A Milk Meter Tolerance Task Group was formed and assigned to this item. Please contact the task group chair for more information:

This item has been assigned to the newly formed Milk Meter Tolerance Task Group for further development. For more information or to provide comment, please contact the task group chair:

Mr. Charlie Stutesman
 Kansas Department of Agriculture
 785-564-6681, charles.stutesman@ks.gov

Existing tolerances are based on the accuracy of the Flow meter itself. The proposed Tolerances are based on Milk Metering Systems where the magnetic flow meter is a part of the Milk Metering system handling milk containing air.

The accuracy of the Flow meter will always be influenced by the way it is used. The only way you can obtain the accuracy described by the manufacture is when the flow meter is operating as a “stand alone” unit and, equally important, only if the product passing through the flow meter is complete air-free.

The submitter provided the following:

During the past 20 years, the need for improved efficiency in the collection of milk has resulted in the use of milk pumping equipment being installed on milk tankers.

One of the most obvious places for a modern Dairy to optimize is the amount of time that the milk tanker uses to make a collection. If you can reduce the collection time at each farmer, the Dairy will be able to get a significant reduction in collection and transport cost for the benefit of the Farmer, Consumer and the Dairy itself. At the same time, you will get an environmental benefit as a result of reduced CO2 in the milk collection process.

The consequence of introducing pump systems on milk tankers is that it causes air to be mixed with the milk which again will influence the accuracy of the magnetic flow-meter mounted in the system. Milk entrains air unlike petroleum liquids which do not. As you know, the flow meter will count anything that passes through the meter – liquid as well as air – and it is therefore essential that as much air as possible is removed from the milk before it reaches the flow-meter. However, it is widely recognized that it is not possible to remove all the air from the milk, which will result in an inaccuracy.

It is therefore essential that the tolerances for vehicle mounted milk pump systems using magnetic flow-meters for determining milk volume reflects today's way of collecting milk. This means that existing Tolerance for milk meters cannot be used when the milk meter is a part of a system where different system parts will influence the accuracy of the count. Such milk metering systems will need to be classified with their own tolerances.

Based on our 25 years of experience as a manufacturer of these systems and more than 3000 installations on milk trucks operating in more than 15 countries, we would like to propose that the Tolerance for Vehicle Mounted Milk Metering Systems is changed from 0.3% to 0.5% and that the tolerances will be listed and classified separately and not be associated with products from the oil industry. Our proposal is consistent with Weights & Measures tolerances accepted around the world.

We hope that the NCWM will consider our proposal and we will be more than happy to meet with you and answer any questions you may have. We believe that a change of Tolerance is necessary in order for the Handbook 44 to reflect today's milk collection and the technical progress within milk collection.

Yours sincerely

Poul Tarp
President POUL TARP A/S

The POUL TARP milk pump system holds an MID approval which is recognized and in accordance with guidelines and standards described in the **OIML - INTERNATIONAL ORGANIZATION OF LEGAL METROLOGY**

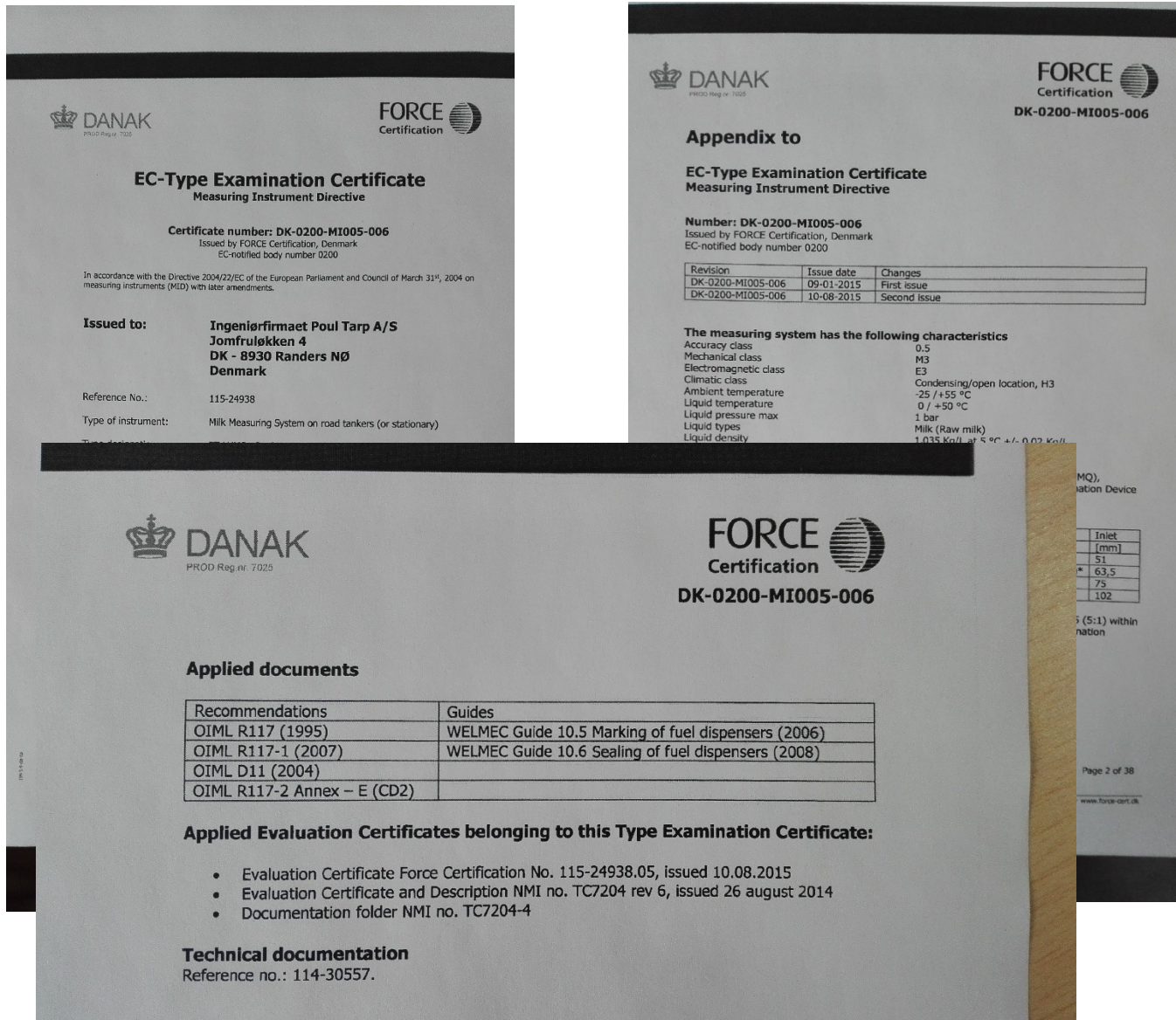

FLOW COMPUTERS REGULATION IN THE US:

The standards related to metrological aspects come from OIML R117-1 for liquids (Dynamic measuring systems for liquids other than water, part 1: Metrological and technical requirements) and documents D11 (General requirements for electronic measuring instruments) and D31 (General requirements for software-controlled measuring instruments) from OIML

2020
NCWM
Interim
Meeting:
The

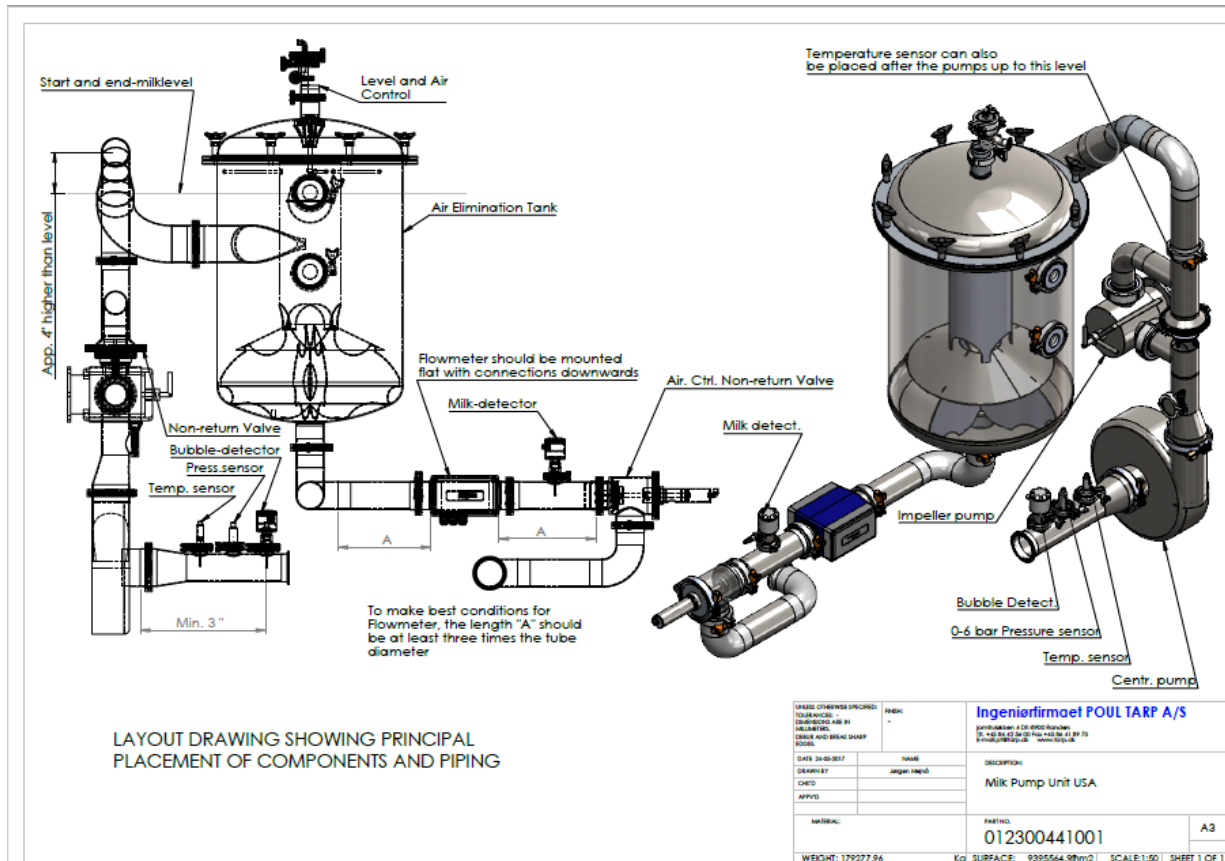

Committee heard from Mr. Carey McMahon (Poul Tarp) who provided a presentation on his company’s VTM milk metering system advocating for expanding tolerances for these systems.

Ms. Leigh Hamilton (Piper) provided a presentation concerning the piper system and stated in her presentation that piper currently has an approved NTEP certificate for their device that is in service in the U.S. Ms. Leigh opposes this item to increase the tolerances for milk meters and noted in her presentation that there may not be a need to increase the tolerances in order to move forward in allowing innovation in milk measurements.

Mr. Charles Stutesman (Kansas) provided a presentation on research that KDA has done on the history of 3 HB 44 Codes (3.31. VTMs, 3.35. Milk Meters, and 4.42. Farm Milk Tanks) and the issue of Piper’s NTEP Certificate. Mr. Stutesman discussed complications involved in measurement of product using various methods and potential short-comings of Piper’s NTEP Certificate.

Mr. Doug Musick (Kansas) stated that he does not believe there is enough information presented to change existing tolerances and noted that the Piper system was only evaluated for accuracy up to a measurement of 300 gallons. He also noted that he believes that Piper’s certificate should be amended to qualify the system for draft sizes up to 300 gallons. Mr. Mike Keilty (Endress + Hauser) commented that he had concerns with Pipers certificate. Ms. Hamilton noted that Piper followed and followed guidelines as provided during the NTEP evaluation. Ms. Diane Lee (NIST OWM) stated that the committee may want to consider a developing status for this item and that more information is needed concerning air elimination methods for milk metering systems.

A representative from the Dairy Farmers of America, stated that they oppose the increase in tolerance but supports the use of VTM metering systems. Mr. Carey McMahon (Poul Tarp) pointed out that the Poul Tarp system can be accurate for any size measurement, but the beginning and end of the measurement would not be accurate measures (within tolerance) due to entrained air in the product when the flow is not uniform. Mr. Dmitri Karimov (MMA) stated that the proposal should be further developed and pointed out that due to the tolerance structure becoming more stringent as the volume of the measurement increases, the acceptance tolerance at 500 gallons is unreasonable. Mr. Hal Prince (Florida) stated that he does not agree with expanding the tolerances. Mr. Prince believes that air elimination should be the focus and that the proposal should be assigned to a task group. Mrs. Tina Butcher (NIST OWM) noted that testing should be performed using multiple quantities and flowrates. Mr. Charles Stutesman (KS) pointed out that confusion is generated by multiple HB 44 codes addressing the measurement of milk and that the proposal should be assigned to a TG to sort this out. Mr. Stutesman also pointed out there is no requirements in HB 44 for air elimination pertaining to milk metering in these codes. Mrs. Butcher noted that the current HB 44 requirements may not be flexible enough for this new technology and that the existing codes may need to be reviewed and updated.

Ms. Leigh Hamilton (Piper) stated that this is not simply a consideration of only a change in tolerances. There are other requirements (currently in the OIML standard) that should also be considered in making any changes to the existing HB 44 requirements. Mr. Mike Keilty (Endress+Hauser) stated that air elimination is a difficult problem to mitigate and noted that he is not sure if it is necessary to expand the existing tolerances or make other amendments. Mr. Carey McMahon (Poul Tarp) stated that using the existing HB 44 tolerances in the VTM Code, at a draft of 5000 gallons, the tolerance value is highly unreasonable (KS) noted that the type evaluation performed on the Piper system was limited to a draft of 300 gallons. If evaluation had included other draft sizes, the Piper system may have failed the testing.

Mr. Ken Ramsburg (Maryland) stated that the proposal should be given a developing status. Mr. Ramsburg agreed that there is no existing requirement for this type of system addressing air elimination and stated that the flow meter, air eliminator, plumbing, and pumps all need to be considered during evaluation and the evaluation should be conducted on the system.

Mr. Tim Chesser (Arkansas) questioned whether the flow meter used in the system is appropriate and noted that there are many unanswered questions surrounding this issue. Mr. Jim Willis (NY) recommended a developing status for this item. Mr. Kevin Schnepf (California) stated that although he is opposed to relaxing existing tolerances, he supports the development of this proposal by an assigned task group.

During the Committee's work session, the committee agreed that this item has merit and should be given an Assigned status. The charge to the assigned task group will be to address three NIST HB 44 codes (VTM, Farm Milk Tanks and Milk meters) to review the requirements and tolerances found in these codes and assess the need for changes.

2020 NCWM Annual Meeting: Due to the 2020 Covid-19 pandemic, this meeting was adjourned to January 2021, at which time it was held as a virtual meeting. Due to constraint of time, only those items designated as 2020 Voting Items were addressed. All other items were addressed in the subsequent 2021 NCWM Interim Meeting.

2021 NCWM Interim Meeting: The Committee heard from Mr. Charles Stutesman (KS and Chair of the Milk Meter Task Group) who gave an update on the task group activities. Mr. Stutesman reported that the Milk Meter Task group worked via e-mail communication and reviewed and discussed the proposed Milk Meter Tolerances in Agenda item VTM-20.2. The Milk Meter Task Group also discussed the tolerances that are included in NIST HB 44 for Milk meters in various parts of HB 44 which include the VTM, Section 3.31, Farm Milk Tanks, Section 4.42., Mass Flow Meters, Section 3.37, and Milk Meters, Section 3.35. Mr. Stutesman also reported that the task group reviewed OIML tolerances for milk meters. Mr. Stutesman stated that after a review of the various tolerances, the task group agreed that the OIML tolerances provide tolerances that encompassed the system of measuring milk and not just a tolerance for the performance of the meter. The Milk Meter Task group agreed with proposing the use of the OIML milk meter tolerance as the milk meter tolerances in the VTM code. Mr. Stutesman provided a copy of the proposed changes to VTM-20.2. The proposed tolerances will align the tolerances in the VTM Code for Milk Meters with OIML Milk Meter Tolerances. Mr. Stutesman requested that this item move forward as a Voting item. The Committee also heard from Clark Cooney who noted that he supported the items as Developing because one company mentioned meeting the existing tolerances. It was mentioned that the company's testing was only performed over a limited range of volumes.

During the committee's work session the committee agreed with the proposal from the milk meter task group to adopt OIML tolerances for milk meters in the VTM code, that this item be given a voting status, and that the item under consideration be replaced with the work groups proposal to adopt OIML tolerances. The committee also agreed with expanding the task group to

address other milk meter codes in NIST HB 44. The Item Under Consideration above are the tolerances agreed to by the milk meter task group and that align with OIML tolerances.

Note: For reference, the item under consideration that was included in the 2021 interim meeting agenda is provided below:

| Table 2. Tolerances for Vehicle-Mounted Milk Meters | | |
|--|--|--|
| Indication (gallons) | Maintenance Tolerance (gallons) | Acceptance Tolerance (gallons) |
| 100 | 0.5 0.6 | 0.3 0.5 |
| 200 | 0.7 1.2 | 0.4 1.0 |
| 300 | 0.9 1.8 | 0.5 1.5 |
| 400 | 1.1 2.4 | 0.6 2.0 |
| 500 | 1.3 3.0 | 0.7 2.5 |
| Over 500 | Add 0.002 0.006 gallons per indicated gallon over 500 | Add 0.001 0.005 gallons per indicated gallon over 500 |

Regional Association Comments:

WWMA 2019 Annual Meeting: The proposal was not addressed by this region.

SWMA 2019 Annual Meeting: The proposal was not addressed by this region.

NEWMA 2019 Interim Meeting: The proposal was not addressed by this region.

2020 Regional Meetings of the WWMA, NEWMA, and SWMA: These regions adhered to a condensed agenda due to the Covid pandemic and did not consider this item.

CWMA 2020 Interim Meeting: Charlie Stutesman (KS & Chair of Milk Meter Tolerance Task Group) updated the committee that the task group was hard at work on this item. The CWMA recommended an Assigned status for this item.

Additional letters, presentations and data may have been part of the Committee’s consideration. Please refer to <https://www.ncwm.com/publication-16> to review these documents.

| CWMA Report |
|---|
| <p>Comments and justification for the regional recommendation to NCWM: <i>(This will appear in NCWM reports)</i></p> <p>Chair of the S&T Committee reported that this item appeared in CWMA Pub 16 as an assigned item incorrectly and should have been presented as a voting item. NCWM has verified that this is the case.</p> <p>Charlie Stutesman (KS), Chair of the Milk Meter Tolerance Task Group reported that the task group is moving forward with a proposal to align NIST Handbook 44 tolerances with OIML tolerances. The task group has made a formal request to the Chairman of the NCWM S&T Committee to expand the scope of the task group and is awaiting final decision on that request. Charlie reported that the current HB44 tolerances may be beyond the manufacturer’s ability and may be in conflict with Fundamental Considerations.</p> <p>The CWMA S&T Committee recommends that this item moves forward as a voting item.</p> |

MFM – MASS FLOW METERS

MFM-21.1 W UR.3.3. Ticket Printer: Customer Ticket

Source:

Restaurant Technologies, Inc.

Purpose:

Allow customers the option of receiving a digital ticket (emailed) in lieu of a printed ticket at time of delivery.

Item Under Consideration:

Amend Handbook 44, Mass Flow Meters Code as follows:

UR.3.3 Ticket Printer: Customer Ticket. – Vehicle-mounted metering systems shall be equipped with a ticket printer which shall be used for all sales where product is delivered through the meter. A copy of the ticket issued by the device shall be left with the customer at the time of delivery or as otherwise specified by the customer. **For systems equipped with the capability of issuing an electronic receipt, ticket, or other recorded representation, the customer may be given the option to receive any required information electronically (e.g., via email, cell phone, website, etc.) in lieu of a hard copy.**

Previous Action:

- N/A

Original Justification:

- 1) Our customers are requesting receipt of delivery ticket via email.
- 2) We deliver bulk cooking oil to restaurants, often during non-operating hours. When nobody from the restaurant is present to receive the delivery ticket, it is stuck in or taped to the back door, and often ends up lost. Our customers are requesting that we **do not** leave a hard copy behind.
- 3) All of our sales are private contract sales; we do not sell to the public. Therefore, the need for a hard copy delivery ticket is not as critical as would be in a public sale setting.
- 4) In addition to electronic receipts, our customers are granted access to a website that shows their daily usage of cooking oil and contains direct links to electronic delivery tickets. This website will allow the customer to view all of their delivery tickets to date, and is in addition to the emailed delivery ticket.
- 5) Our metering system is NTEP certified and in full compliance of Handbook 44. All required delivery ticket content, per Section 3.37, is captured in electronic format.

Language similar to what is being proposed above was added in 2014 to Section 1.10, Paragraph G-S.5.6 in an attempt to allow electronic delivery tickets. While this change was intended to apply to all sections of the code, it conflicts with existing language in the General Code (ref. Code Application, G-A.2) that does not allow the language in the General Code to supersede the requirements of the specific code. So in the case of Section 3.37, the code language requiring a hard copy ticket takes precedent.

The submitters assume there will be no arguments as this proposal is similar, in language and intent, to what was added in 2014 to Section 1.10, Paragraph G-S.5.6.

The submitter requested voting status for this item in 2021.

Comments in Favor:

Regulatory:

-

Industry:

- Support moving this item forward.

Advisory:

-

Comments Against:

Regulatory:

- There is still a need for printed ticket. It was explained that they are being service when the establishment is closed so electronic tickets are requested.

Industry:

- Merge this item with block 4 or withdraw the item.

Advisory:

- Block 4 in this agenda includes a proposal for a change to the same paragraph.

Neutral Comments:

Regulatory:

-

Industry:

-

Advisory:

-

Item Development:

The committee agreed to withdraw this item due to comments that expressed the need for a printed receipt.

Regional Associations' Comments:

WWMA 2020 Annual Meeting: Matthew Douglas (CA DMS) believes the paragraph needs to be word smithed. The Committee agrees to recommend the item be given a developing status. Recommendations to the submitter to further define the intent of the item and continued vetting through the regions.

SWMA 2020 Annual Meeting: No report on this item.

NEWMA 2020 Interim Meeting: The Committee agrees with the body that this proposal does not have merit, is redundant and should be considered as a Withdrawn item. During open hearings, the Committee received comments from multiple agencies that the general code already provides for the intent of the submitted item.

CWMA 2020 Interim Meeting: The S&T Committee heard several comments from regulatory officials about the merits of this item. We recommend this item move forward as a Developing item and suggest that the developer of this item and the Block 4 items work together on this issue.

Additional letters, presentation and data may have been submitted for consideration with this item. Please refer to <https://www.ncwm.com/publication-16> to review these documents.

| CWMA Report |
|--|
| Comments and justification for the regional recommendation to NCWM: <i>(This will appear in NCWM reports)</i> |
| No comments on withdrawn items. |

EVF – ELECTRIC VEHICLE FUELING SYSTEMS

EVF-21.1 W A.1. General

Source:

ABB, BTCPower, Electrify America, Edison Electric Institute, EVConnect, EVgo, Greenlots, Rivian, Siemens, Tesla, Tritium

Purpose:

To provide clarity on how Handbook 44, Sec. 3.4 tentative code will apply to existing EVSE that are in the ground before it becomes effective by identifying which elements are non-retroactive.

Item Under Consideration:

Amend Handbook 44, Electric Vehicle Fueling Systems as follows:

A.1. General – This code applies to devices, accessories, and systems used for the measurement of electricity dispensed in vehicle fuel applications wherein a quantity determination or statement of measure is used wholly or partially as a basis for sale or upon which a charge for service is based.

A.1.1 Effective Dates for DC EVSE – All DC EVSE used for commercial purposes and put into service on or before January 1, 2023 are exempt from this standard for a period of 10 years from the date put into service. comply

A 1.2 Effective Dates for AC EVSE – All AC EVSE used for commercial purposes and put into service on or before January 1, 2022 are exempt from this standard for a period of 10 years from the date put into service.

Previous Action:

- N/A

Original Justification:

While it is important to ensure that consumers are receiving accurate and transparent information regarding the accuracy of EV charging stations, the cost to retrofit existing stations that often do not include an integrated meter, especially DCFC where commercial DC metering technology is not readily available today, will be cost prohibitive. In CA Initial Statement of Reasons (ISOR) for adopting specifications and tolerances requirement for commercial EVSE, CA estimated that it costs approximately \$4,500 to upgrade existing Level 2 stations and \$20,000 to upgrade existing DCFC. To put this into context, CA DMS utilized 2015 DOE data stating that the average commercial Level 2 EVSE costs between \$3,000-\$6,000 and the average DCFC up to \$40,000 or more. The retrofit costs would represent a significant investment amount that does not seem warranted. The ISOR is available here: https://www.cdfa.ca.gov/dms/pdfs/regulations/EVSE_ISOR.pdf. According to DOE AFDC station locator there are 23,000 level 2 station with 66,000 connectors in the U.S. and 3,700 DCFC stations with 14,000 connectors. Being conservative and utilizing just the number of stations, it would cost \$92M to upgrade the existing Level 2 station in the U.S. today and \$74M to upgrade the existing DCFC stations, a number that is expected to grow as more stations are deployed. Placing this excessive upgrade burden on manufacturers and network operators is not feasible and an alternative pathway needs to be explored to ensure consumer transparency and EVSE accuracy for existing stations without requiring extensive retrofits. This number also does not include the amount of public funding across various states that has been invested in these EVSE that would prematurely potentially be ripped out and replaced. It could also have the unintended consequence that the EV industry stops charging for charging services at existing sites or shut them down if the investment in retrofits is greater than the benefit of continuing to operate. Stranded assets across the country are a valid concern and should not be taken lightly. It is important to not prematurely replace EVSE in the field until the useful life of the system has been obtained. Spending a significant amount of capital to upgrade existing stations rather than investing in new infrastructure does not appear aligned with EV deployment goals. Therefore, it is recommended that there is consideration for making sure requirements are non-retroactive and there is a phase in timeline for existing stations. The language utilized above is similar to what CA DMS implemented, which was the first state to adopt a version of Handbook 44 Sec 3.4 for EVSE. The date for DC EVSE is set at January 1, 2023 to match California's timeline but also because this is when DC metering technology is expected to be commercially available in the market and

integrated into DC EVSE by most EVSE manufacturers that are either working on their own product or with third party meter manufacturers.

In general, it appears that there is some openness to considering how legacy EVSE that are in the ground today should be treated when considering that DC metering technology integrated into the EVSE was not commercially available when many of these stations were developed. The main concern that has been raised is regarding whether there should be an overall exemption for existing EVSE to the measurement provisions in HB 44 Sec 3.4 or whether existing EVSE should be exempt from certain requirements in the subsections of Sec 3.4 that are not feasible to attain. In reviewing the subsections of Sec 3.4, the proposal submitters determined that it would not be feasible to meet most subsections of Sec 3.4 with equipment that is in the ground with the exception of S.5 Marking (except S.5.2) and S.6 printing requirements. To ensure there is not confusion between which stations were in the ground prior to dates referenced above, EVSE owners and operators will need to work with local weights and measures officials on a self-reporting mechanisms or some other mechanism for tracking station service dates. CA will be the first state that will need to determine how this process will operate in the field given it has already adopted the exemption noted above and compliance for new AC stations is effective January 1, 2021. On the consumer side, EVSE operators and owners today can provide certain provisions to ensure the accuracy of the commercial transaction that can be facilitated outside of having a meter integrated into the EVSE. For instance, some owners and operators may be able to utilize the accuracy that is traceable via the measurement technology in the EV that accounts for any losses and ensure the consumer is being accurately and fairly billed for what he or she is receiving.

The submitter requested voting status for this item in 2021.

Comments in Favor:

Regulatory:

- Supported Developing status, but noted that an exemption from requirements in the handbook is not common and that the life span of the equipment may only be seven to ten years

Industry:

- Supported Developing status.
- Supported this item.
- Expressed concerns with allowing an exemption for 10-years and equipment should be able to meet the requirements and supports a Developing status for this item

Advisory:

-

Comments Against:

Regulatory:

-

Industry:

-

Advisory:

- The proposal is not clear as written and expressed concerns with an exemption for 10 years.

Neutral Comments:

Regulatory:

-

Industry:

-

Advisory:

-

Item Development:

During the Committees work session, the committee agreed to a Developing status for this item. The Committee suggests that the submitters of this item consider the responses to the proposal from the regional meetings, NIST, OWM and EVFS work group and update the item under consideration to address the comments and as necessary prepare a revised proposal for the EVFS work group to address the concerns with this item.

Regional Associations’ Comments:

WWMA 2020 Annual Meeting: Tesla, EV Connect, EV Go – Francesca Wahl – presentation: Sec 3.4 charging evolves and technology changes. They are trying to address the tentative code CA is now using. Charging involves many different speeds and levels. Trying to fit charging into what consumers are doing rather than making it a separate event (based on convenience). Metering technology is now becoming more commercial. Retro-fit costs are excessive. Add the 10-year phase-in that CA currently recognizes. Copy of the presentation that was provided is available on the WWMA website. Kevin Schnepf (California DMS) commented that the 10-year extension was political in CA and may not be necessary at the national level. He believes the indicator should not be solely tied to a mobile device. The extension of the accuracy may not be necessary for the national level. Note that some areas have sub-meters at residential units that fall under commercial device applications. California-DMS would ask the committees look at the concessions that California made as to whether this should be applied to NIST HB 44. Mahesh Albuquerque (Colorado) supports all the proposals to move on to a voting item. He agrees with the comments made but wants to keep the process moving forward. Perhaps change the exception time to say “up to 10 years” allowing jurisdictions to make their own determination. Ms. Juana Williams (NIST OWM) submitted written comment after open hearings and will be posted on the WWMA website.

The Committee agrees to recommend this item be assigned a Developing status. The Committee also recommends the submitter continue to work with their stakeholders and jurisdictions to develop the item and consider language with regards to the 10-year period.

SWMA 2020 Annual Meeting: During the Open Hearings, the Committee heard from Ms. Francesca Wahl who gave a presentation on the industry’s support of these items, and willingness to develop them. The Committee also heard from Ms. Tina Butcher (OWM) who stated that the item needs terminology work, and that she had concerns about a 10-year blanket exemption for these devices. She also noted that some of these devices do not currently contain a meter. The Committee also heard from Ken Ramsburg (Maryland) who stated that he did not agree with a blanket exemption.

After consideration of this item the Committee recommends that this item be given Developing status and assigned to the national work group.

NEWMA 2020 Interim Meeting: The Committee agrees with comments heard from the body that this proposal is unclear and a blanket exemption for certain devices in the same category would be contrary to the NCWM mandate to create equity in the marketplace and could create a competitive edge against other fuels or competing devices. Additionally, the ten-year exemption in an evolving technological field is not appropriate. Some suggestions were heard that the proposal could conflict with User Requirements and allow a generation of devices to be used for ten years without compliance. Therefore, the Committee recommends this proposal be Withdrawn.

CWMA 2020 Interim Meeting: The S&T committee heard numerous comments of concern from regulatory officials on this item. The key issues addressed were the 10-year exemption, the blanket exemption from the EVFS codes, and the competitive advantage this item may present to the industry. We feel this item has merit and feel a more appropriate course of action would be to request exemptions from specific requirements vs. a blanket exemption. We recommend this item move forward as a Developing item.

Additional letters, presentation and data may have been submitted for consideration with this item. Please refer to <https://www.ncwm.com/publication-16> to review these documents.

| |
|--|
| CWMA Report |
| Comments and justification for the regional recommendation to NCWM: <i>(This will appear in NCWM reports)</i> |

Juana Williams (NIST OWM) provided comments on this item. The item is unclear. The potential lies for an entire generation of device to be exempt from Section 3.40 for entire period of use. Companies have expended money and resource to be compliant and allowing such an exemptions create competitive disadvantage environment in the marketplace. The USNWG will not consider this item until it is reworked by the submitter. Charlie Stutesman (KS) feels this item should be withdrawn as a 10 year exemption not acceptable. NIST Handbook 44, Section 3.40, has been published as a tentative code since 2015 and should be a consideration in the establishment of enforcement dates.

The CWMA S&T Committee recommends that this item be withdrawn.

EVF-21.2 W A.2. Exceptions

Source:

ABB, BTCPower, Electrify America, Edison Electric Institute, EVConnect, EVgo, Greenlots, Rivian, Siemens, Tesla, Tritium

Purpose:

To clarify that this code does not apply to EVSE that are not available for public use.

Item Under Consideration:

Amend Handbook 44, Electric Vehicle Fueling Systems as follows:

A.2. Exceptions. – This code does not apply to:

- (a) The use of any measure or measuring device owned, maintained, and used by a public utility or municipality only in connection with measuring electricity subject to the authority having jurisdiction such as the Public Utilities Commission.
- (b) Electric Vehicle Supply Equipment (EVSEs) used solely for dispensing electrical energy in connection with operations in which the amount dispensed does not affect customer charges or compensation.
- (c) The wholesale delivery of electricity.
- (d) EVSE located where access and control is restricted for private use, e.g., EVSE placed at a place of residence, including a multiunit residence, for the use of inhabitants; EVSE at a workplace for the use of employees or workers; and EVSE in locations not open to the general public.**
- (e) EVSE used exclusively for fleet sales and other price contract sales.**

Previous Action:

- N/A

Original Justification:

Private access locations such as workplaces or residential charging at multi-unit dwellings should not be subject to commercial weights and measures regulations if a commercial transaction based on volume or quantity is not taking place. While this may already implied via the definitions under HB 44 and commercial transactions, it should be clarified for the EVSE subsection. For instance, an apartment complex may provide tenant charging access that is billed either as part of the rent agreement or submetered via an existing utility bill mechanism. In this instance, there is a pre-defined contract between the landlord and tenant to provide this service and for the tenant to pay for this service. However, this service is not available to the public – i.e. it does not include visitor parking. It would be particularly onerous for a small multi-unit dwellings or even an Airbnb to comply with this requirement and unnecessary given the charging cost could be priced into a contract sale.

The top concern is that the provision may be unnecessary, as EVSE restricted exclusively for non-commercial applications is already exempt from HB 44 standards. That said, industry hates uncertainty. The clarity provided by the revision would provide unequivocal regulatory certainty for potential EVSE owners and operators.

Another concern is that commercial EV charging companies may seek to use the exemption as a loophole to evade enforcement of HB 44 standards. However, the suggested change is drafted with that possibility in mind. All three use-cases exempted by the revision are non-commercial in nature. Chargers open to the public and/or used for commercial transactions would still be subject to regulation.

The submitter requested voting status for this item in 2021.

Comments in Favor:

Regulatory:

-

Industry:

- Supported the item.

Advisory:

-

Comments Against:

Regulatory:

- Expressed issues with the language of the proposal and suggested that the item be withdrawn.

Industry:

- Expressed concerns with this item and suggested that this item be withdrawn.

Advisory:

- Reviewed some points addressed in the NIST OWM Analysis.

Neutral Comments:

Regulatory:

-

Industry:

-

Advisory:

-

Item Development:

During the Committee's work session, the Committee decided to withdraw this item and expressed concerns with providing an exemption from the entire NIST HB 44 code to devices that provide commercial transactions.

Regional Associations' Comments:

WWMA 2020 Annual Meeting: Kurt Floren (Los Angeles Co., CA) commented his concerns regarding exceptions when charges are being imposed when private installations are later opening up to the general public. Initially they may fall under the exception but if they change their position from a private to a public site, how would this be addressed? Suggests the proposal needs to be clarified. A blanket exemption is not sufficient. Thought needs to be given to devices falling under the exception may not be appropriate nationwide. Mr. Jeremy Whaling (EVgo) commented in response to Mr. Kurt Floren (Los Angeles County, California) that if a business went from private to public their devices would have to comply. Brad Juhasz (EVConnect) commented that most charging ports are level 2 charging sites. The goal is to avoid unnecessary costs to participants in controlled applications. Fleet sales and contract sales are common in private work and living spaces and the interest to the general public is not in play. Matthew Douglas (CA DMS) concurred with Mr. Floren's concerns. Also added 21.2, A.2.(e), should be amended

to stay under jurisdictional regulation. Tina Butcher (NIST OWM) commented, if the device is being used commercially, Handbook 44 applications will apply. The general approach to NIST HB 44; consumers and businesses expect to see the amount, cost and final amount the device charges. Fleet and contract sales are common exceptions throughout HB 44. The current proposal is an exception to all the requirements. A better method is to identify solutions where they may not comply with current code. Rather than allow a blanket exception it may be better to pinpoint areas where exceptions need to be addressed. She also commented that the US national working group on EVF fueling discussed these items and did not reach a consensus. Lots of debate. If a device is not being used commercially it's not covered by HB 44. Comment on exceptions: consumers and businesses expect to determine how much they receive and pay. The transactional info still needs to be provided but how it is provided may be different. Fleet sales for example do not need to show pricing because that has already been agreed upon maybe through a contract. Maybe identify those code sections where compliance needs to be met. Rather than give a blanket exception, consider whether specific points can be given exceptions. Mr. Kevin Schnepf (CA) Fleet sale accuracy needs to be clarified noncommercial and non-public can easily become public. Concerned to the blanket exclusion regarding multiunit residences. Mahesh Albuquerque (CO) added all comments are good but still recommends moving forward. Additionally, he would like to harmonize all the dates. Ms. Francesca Wahl (Tesla) clarified the blanket exception was chosen because it was straight forward but realizes it may need to be more specific. They are open to working on this moving forward.

The Committee agrees, and recommends this item be assigned a Developing status. The Committee also recommends the submitter continue to work with their stakeholders and jurisdictions to develop the item.

SWMA 2020 Annual Meeting: During the Open Hearings the Committee heard from Mr. Ken Ramsburg (Maryland) who stated that D and E needed further development. He stated that he had no issue with home chargers being considered non-commercial, but not the entire designation of “non-public” stations, such as those at workplaces. Ken also stated that he does not support the exception for stations used in contract sales, as that exemption does not exist for petroleum fueling stations. The Committee also heard from Ms. Tina Butcher (NIST OWM) who stated that she agrees with Mr. Ramsburg. Ms. Butcher also stated that if these devices are not commercial, then this statement is not needed, as Handbook 44 is for the regulation of commercial devices. Ms. Butcher also clarified that although exceptions can exist, such as those for fleet sales, the device is still considered commercial.

After consideration of this item the Committee recommends that it be Withdrawn.

NEWMA 2020 Interim Meeting: The Committee agrees with the body that this proposal has no merit and should be considered a Withdrawn Item. During the open hearings, the Committee heard multiple comments that the proposal was too vague and allowed for instances where devices used in commerce would be exempted from testing. All commercial weighing and measuring devices are subject to Handbook 44 regulations and non-public devices can still be used commercially. The national work group could not come to a consensus on this item.

CWMA 2020 Interim Meeting: The S&T committee heard a number of concerns from regulatory officials about a blanket exemption from the EVFS code for EVSE devices located at a multi-unit residence, workplace, or other locations not open to the public. Concerns were also heard from regulatory officials about a blanket exemption for EVSE devices used exclusively for fleet sales and other price contract sales. We feel this issue is likely already covered by G-A.1. paragraph (a). We recommend this item be Withdrawn.

Additional letters, presentation and data may have been submitted for consideration with this item. Please refer to <https://www.ncwm.com/publication-16> to review these documents.

| |
|--|
| CWMA Report |
| Comments and justification for the regional recommendation to NCWM: <i>(This will appear in NCWM reports)</i> |
| No comments on withdrawn items. |

EVF-20.1 D S.1.3.2. EVSE Value of the Smallest Unit.

Note: The item under consideration includes editorial changes by the submitter, NIST, OWM, to correctly reflect the appropriate strikeout/underlines when editing existing text in NIST HB 44. NIST OWM included other recommendations for changes to the text in their analysis but these changes were more than editorial.

Source:
NIST OWM

Purpose:
Specify the maximum permissible value of the indicated and/or recorded electrical energy unit by an EVSE. Establish a value for the energy unit of measurement (kilowatt-hour) that is: suitable for all commercial transactions and does not significantly lengthen the time (by a factor of 25) to conduct a test of an EVSE.

Item Under Consideration:
Amend Handbook 44, Electric Vehicle Fueling Systems follows:

S.1.3. EVSE Units.

S.1.3.2. EVSE Value of Smallest Unit. – The value of the smallest unit of indicated delivery by an EVSE, and recorded delivery if the EVSE is equipped to record, shall **not** be **greater than 0.0005 MJ or 0.0001 kWh.**

(Amended 2020)

Background/Discussion:

This item has been assigned to the submitter for further development. For more information or to provide comment, please contact:

Ms. Juana Williams
NIST Office of Weights and Measures
301-975-3989, juana.williams@nist.gov

In 2014 the U.S. National Work Group (USNWG) on Electric Vehicle Fueling and Submetering (EVFS) deliberated about the Electric Vehicle Fueling System's appropriate value for the display of electrical energy when sold in kilowatt-hour units of measurement. Based on the typical EVSE's ratings (i.e., charging power and current) the work group agreed that the value of the indicated or recorded charge should be in increments of 0.001-kilowatt hour (kWh). Members of the work group noted that the value could be inexpensively modified. Most recently it has been determined that the currently specified value of 0.001 kWh for the electricity unit of measurement in relation to the time for a test standard to complete an accuracy test at 10 % of the maximum deliverable amperes increases the length of the test by a factor of 25.

Each NIST Handbook 44 code specifies the appropriate unit(s) of measurement (indicated and recorded) that is permitted for all device applications that a code applies to. The accepted SI (metric) unit of measurement for a device application in each code is in most cases followed by its equivalent corresponding recognized U. S. customary unit. Measurements in SI or customary units can be supported through calibrations by an accredited (or recognized) laboratory. Each handbook code also specifies the maximum value for a unit of measurement that can be indicated or recorded by the device for a specific product application or rate of delivery.

Unlike the scales' codes, the EVSE code specifies the "smallest" value of the unit that is permitted to be indicated for the quantity of electricity being measured; whereas the scales codes specify the value that the unit *shall be equal to* or *shall not be greater than*. The language in the scales code clearly states that there is only one acceptable value for the unit of measurement or establishes a value that the unit cannot exceed.

The measuring devices codes specify that the smallest value for the unit of delivery indicated or recorded for a commodity *shall not exceed* a specific value. The value varies depending on the type of commodity and/or device's flow rate or falls into the category of all other meters. Yet it is clear the unit of measurement's value cannot be exceeded although lesser values are

acceptable if the device has that capability, maintains accuracy, and sales in that particular indicated or recorded quantity are appropriate.

To provide adequate resolution (i.e., value of the kWh unit) in the EVSE's customer display of the electrical energy transaction information and to facilitate accuracy testing of the system two alternate proposals were developed that recommend somewhat different modifications of paragraph S.1.3.2. EVSE Value of Smallest Unit.

The first option for modifying the code that was developed and circulated to the Electric Vehicle Fueling Equipment (EVFE) Subgroup for consideration would be to recognize EVSEs equipped with a customer display of 0.005 MJ or 0.001 kWh and a test mode display on the EVSE face, accessible internally, or activated by controls accessed by the official that indicates in 0.0005 MJ or 0.0001 kWh increments.

Also, part of the information circulated to the Subgroup included a second option of modifying the value of the displayed and/or recorded kilowatt-hour energy units from 0.005 MJ or 0.001 kWh to a higher resolution of 0.0005 MJ or 0.0001 kWh. The first option shown below would modify paragraph S.1.3. EVSE Units to include a new subparagraph S.1.3.3. EVSE Value of Smallest Unit Test Mode to allow for a higher resolution value of the kilowatt-hour indications as a test mode display separate from the display used for the display transaction. The test mode display would either continuously indicate on the face of the dispenser or an internal display accessible during the inspection and test of the dispenser or display the quantity by using controls on the device.

S.1.3. EVSE Units.

S.1.3.3. EVSE Value of Smallest Unit Test Mode. – EVSE shall display the electricity measured for each transaction in 0.0005 MJ or 0.0001 kWh energy units through:

- (a) a continuous indication on the face of the EVSE;**
- (b) an internal display accessible during the inspection and test of the EVSE; or**
- (c) a display of the quantity by using controls on the device.**

(Added)

S.1.3.34. Value Defined. ...

(Amended 2020)

A test display mode is permissible for the mass flow meter compressed natural gas and liquefied natural gas dispenser applications. Although this option was entertained by the USNWG in 2014, further discussion would be needed to provide guidelines on how the indication must operate to comply with handbook requirements. When this option was circulated in 2019 to the USNWG EVFE Subgroup, the interest was more in favor of a single higher resolution display (i.e., 0.0001 kWh). However, there was some concern expressed about potential rounding issues were there to be two separate indications having different display resolution.

Since the 2015 adoption of Handbook 44, Section 3.40 paragraph S.1.3.2. EVSE Value of Smallest Unit has specified that the smallest unit of indicated delivery by an EVSE, and recorded delivery if the EVSE is equipped to record, shall not be greater than 0.005 MJ or 0.001 kWh. It is anticipated that the community would question the cost to modify the equipment's design; however, after discussions about the possible quantity value of "d" as large as 0.1 kWh, industry indicated that the value for the unit of measurement could be inexpensively modified. The EVSE code has tentative status and to date no equipment has undergone the type evaluation process. The community anticipates there will be slight modifications to requirements and test procedures to address various generations of equipment, design configurations, and business models in the marketplace.

2020 NCWM Interim Meeting: The Committee heard from Mrs. Tina Butcher (NIST OWM) who reported that this item was submitted by NIST OWM to modify the value for "d" specified for Kilowatt-hour for EVSEs to recommend a higher resolution for "d" that does not significantly lengthen the time to conduct the accuracy test of EVSE. Mrs. Butcher added that it is uncertain if the item is fully developed and request it be made developing. Mr. Kevin Schnepf (CA) stated California has already made

the change, however he supports a Developing status for this item. Mr. Jim Willis (NY) provided similar comments to those of Mr. Schnepf. *Note: The NIST OWM analysis includes a recommended that the phrase “shall not be greater than” be removed.*

During the Committee’s work session, the committee agreed that this item should be given a Developing status to allow the submitter to continue to work with the work group concerning this item.

Regional Association Comments:

WWMA 2019 Annual Meeting: Mr. Clark Cooney (CA) stated his support for this item. The Committee agrees that the item is fully developed and should be given a Voting status.

SWMA 2019 Annual Meeting: During Open Hearings, the Committee heard no comments on this item. After consideration of this item the Committee decided to make No Recommendation on this item.

NEWMA 2019 Interim Meeting: The Committee and the body agree that this item be moved to a developing status as it has merit. During open hearings, Mr. Steve Timar (NY) questioned if MMQ should also be changed. Mr. Jim Willis (New York) stated that moving the resolution to 1/10,000th may be a little extreme and recommends changing the resolution to 1/1000th. He also questions whether changing the resolution effects the time to conduct a test.

2020 Regional Meetings of the WWMA, NEWMA, and SWMA: These regions adhered to a condensed agenda due to the Covid pandemic and did not consider this item.

CWMA 2020 Interim Meeting: The only comments heard on this item by the S&T committee were from Tina Butcher (NIST OWM) giving an update from the USNWG on EVFS for this item have yet to reach a consensus on the proposed or alternate language and asked the committee to recommend a developing status for this item. The committee concurs with her recommendation.

Additional letters, presentations and data may have been part of the Committee’s consideration. Please refer to <https://www.ncwm.com/publication-16> to review these documents.

| CWMA Report |
|--|
| <p>Comments and justification for the regional recommendation to NCWM: <i>(This will appear in NCWM reports)</i></p> <p>Juana Williams (NIST OWM) provided information on this item. OWM recommends that this item remain developing. She suggested the following change to the proposal:</p> <p>S.1.3. EVSE Units.</p> <p style="padding-left: 40px;">S.1.3.2. EVSE Value of Smallest Unit. – The value of the smallest unit of indicated delivery by an EVSE, and recorded delivery if the EVSE is equipped to record, shall not be greater than 0.0005 MJ or 0.0001 kWh.</p> <p style="padding-left: 40px;">(Amended 2020)</p> <p>USNWG has not reached a consensus on this item and recommends that it remain developing. The CWMA S&T Committee recommends that this item remain developing.</p> |

EVF-20.2 V Definitions: Submeter

Note: This item will update Section 3.40 Electric Vehicle Fueling Systems - Tentative Code. The item under consideration reflects changes that were made by the Committee during its 2020 Annual Meeting work session so that it shows the correct strikeouts and underlines needed when editing existing text in NIST HB 44.

Source:
USNWG EVF&S

Purpose:
To provide a clear technical definition of what a sub-meter is.

Item Under Consideration:

Amend Handbook 44, Section 3.40 as follows:

submeter. – A meter or meter system downstream of the ~~furnished, owned, installed, and maintained by the customer who is served through a utility owned~~ master meter. [3.40]

(Added 20XX)

Background/Discussion:

Changes being made to this definition up-dates the terminology being used in the Watthour Metering sections by the Working Groups Submeter watt-hour Subgroup. There has been confusion in some state jurisdictions causing the enforcement agency to believe that only a Utility could operate a sub metering system. A technical definition that does not use references to “Utility” which appears to be interpreted as allowed only if provided by the “Serving Utility”. This definition also provides some technical consideration on how to categorize meters. UL/IEC/CSA61010-01 ED3 provides technical detail on where a meter can be in building wire infrastructure. This definition approach would make a clear distinction a specific meter’s ability to be in various places in the wiring infrastructure, in technical terms and clear up whether it must be specifically provisioned by the “Serving Utility”. The following excerpts are referenced from 61010-1© IEC:2010 Annex K identifying, technically, where meters of specific protection design can be. If there is another requirement to identify sales and service ownership and allowances, it is recommended that this be done elsewhere in the code.

- **OVERVOLTAGE CATEGORY IV** is for equipment installed at or near the origin of the electrical supply to a building, between the building entrance and the main distribution board. Such equipment may include electricity tariff meters and primary overcurrent protection devices. Manufacturers may also design equipment for OVERVOLTAGE CATEGORY IV when an even higher degree of reliability and availability is desired.
- **OVERVOLTAGE CATEGORY III** is for equipment intended to form part of a building wiring installation. Such equipment includes socket outlets, fuse panels, and some MAINS installation control equipment. Manufacturers may also design equipment for OVERVOLTAGE CATEGORY III when a higher degree of reliability and availability is desired.
- **OVERVOLTAGE CATEGORY II** is for equipment intended to be supplied from the building wiring. It applies both to plug-connected equipment and to PERMANENTLY CONNECTED EQUIPMENT. Sub-clause 6.7 covers only the requirements for OVERVOLTAGE CATEGORY II with a nominal supply voltage up to 300 V. The requirements for higher OVERVOLTAGE CATEGORIES and for OVERVOLTAGE CATEGORY II with a nominal supply voltage above 300 V are covered by this annex.
- **OVERVOLTAGE CATEGORY I** is used, within the context of IEC 60364-4-44, for equipment intended to be connected to a MAINS supply in which means have been taken to substantially and reliably reduce TRANSIENT OVERVOLTAGES to a level where they cannot cause a HAZARD.
- OVERVOLTAGE CATEGORY I is not relevant to this standard.

Generalizing the definition allows water, gas and other revenue billing categories of meter to be included. It does not express to ownership and operation of submeter. That should also be done elsewhere in the code.

The submitter commented that at this time the only opposing argument might be that a “Serving Utility” may react to not being in control of these devices. The code should also be clear in other areas besides the definition for understanding abilities to use a sub-metering for tariff billing down-stream of the mains meter.

2020 NCWM Interim Meeting: The Committee heard from Mr. Kurt Floren (Los Angeles County, CA) who asked if there is a definition for “master meter” that is included in the proposal. Mr. Floren noted that a definition is needed. Mrs. Tina Butcher (NIST OWM) agreed with Mr. Floren’s comment and noted that the work group should provide a definition. Mr. Richard Suiter (Richard Suiter Consulting) suggested not using “master meter” but rather “primary” meter instead.

During the Committee work session, the committee agreed that this item should be given a Voting status and that it should be amended to reference the appropriate HB 44 Code section, which is section 3.40.

2020 NCWM Annual Meeting: The committee heard many comments from State Weights and Measures Jurisdictions that this item should be downgraded. Those in support of making the item Informational included Kevin Schnepf (California) and Kurt

Floren (Los Angeles County, California). Steve Harrington (Oregon) and Michael Keilty did not support the item. Tina Butcher (NIST OWM) noted that corrections were needed to the item under consideration to correctly reflect the edits to the definition. Since the definition for submeter is currently in NIST Section 3.40. Electric Vehicle Fueling Systems -Tentative Code, the definition under the item of consideration should appear with appropriate strikeouts to show what changes are being proposed.

During the Committee’s 2020 Annual Meeting work session, the committee agreed to make the item Informational with editorial changes to the item under consideration. The item under consideration above reflects editorial changes that were accepted by the Committee during its 2020 Annual Meeting work session.

Note: For your reference the Item under consideration that was provided in Publication 16 for the 2020 Annual meeting is included below:

Submeter- a meter or meter system downstream of the master meter. [3.40]
(Added 20XX)

Regional Association Comments:

WWMA 2019 Annual Meeting: Ms. Lisa Warfield (NIST OWM) stated that this item is fully developed and ready for a Voting status. Mr. Kevin Merritt (Idaho) asked if this language would apply to an LPG meter? Ms. Warfield responded that this does not apply to an LPG meter and that the definition for “submeter” referred to in this proposal should not be confused with the use of “master meter” as used when referring to calibrations. Mr. Kurt Floren (Los Angeles County, California) asked the question “is the term master meter defined?” Ms. Warfield responded that the term “master meter” is defined and that the definition was derived from that definition from Measurement Canada.

The Committee agrees this proposal has merit and that it is fully developed and should be given a Voting status. The Committee also recognizes that the stated Purpose should be amended to state the change would affect to EVSE Code paragraph 3.40., Appendix D, Definitions as shown below.

~~submeter. — A system furnished, owned, installed, and maintained by the customer who is served through a utility owned master meter. [3.40]~~

Submeter - a meter or meter system downstream of the master meter. [3.40]
(Added 20XX)

Regional Association Comments:

2020 Regional Meetings of the WWMA, NEWMA, and SWMA: These regions adhered to a condensed agenda due to the Covid pandemic and did not consider this item.

CWMA 2020 Interim Meeting: The only comments the S&T committee heard, from both NIST OWM and state regulatory officials, expressed a concern with the use of the word “master meter.” Tina Butcher (NIST OWM) explained that the term “master meter” has a widely accepted definition in the electric vehicle and watt hour industry. We feel this item is fully developed and recommend this item move forward as a voting item.

Additional letters, presentations and data may have been part of the Committee’s consideration. Please refer to <https://www.ncwm.com/publication-16> to review these documents.

| CWMA Report |
|--|
| Comments and justification for the regional recommendation to NCWM: <i>(This will appear in NCWM reports)</i> |
| Juana Williams (NIST OWM) Provided background and technical information on this item. OWM feels this item is fully developed and is ready to be voted on. The CWMA S&T Committee recommends that this item be moved to a Voting item. |

EVF-21.3 W S.1.2. EVSE Indicating Elements, S.2.4.1. Unit Price, S.2.5. EVSE Money-Value Computations., S.2.7. Indication of Delivery

Source:

ABB, BTCPower, Electrify America, Edison Electric Institute, EVConnect, EVgo, Greenlots, Rivian, Siemens, Tesla, Tritium

Purpose:

To provide clarity regarding the options available for the primary indicating element that can be utilized to display commercial transactions for EVSE to the consumer and utilized during the inspection of the measurement system for EVSE.

Item Under Consideration:

Amend Handbook 44, Electric Vehicle Fueling Systems as follows:

S.1.2. EVSE Indicating Elements. – An EVSE used to charge electric vehicles shall include an indicating element that accumulates continuously and displays, for a minimum of 15 seconds at the activation by the user and at the start and end of the transaction, the correct measurement results relative to quantity and total price. Indications shall be clear, definite, accurate, and easily read under normal conditions of operation of the device. All indications and representations of electricity sold shall be clearly identified and separate from other timebased fees indicated by an EVSE that is used for both the sale of electricity as vehicle fuel and the sale of other separate time-based services (e.g., vehicle parking). **The primary indicating element shall be provided using one or more of the means listed below:**

(a) A display device which is integral or adjacent to the EVSE.

(b) A device equipped with the means to establish a secure connection to a personal remote/mobile device for display purposes.

(i) The secure connection may be established via wired or wireless means.

(ii) A personal remote/mobile device includes, but is not limited to a smartphone (cell phone), tablet, or laptop computer equipped with a digital display.

(iii) All measuring, indicating and recording elements used in an electric vehicle fueling system shall operate normally while the display application is running on the remote/mobile device.

(iv) The display application running on the remote/personal device shall be freely available and must allow for unannounced inspections by weights and measures officials.

S.1.2.1.(c) Multiple EVSEs Associated with a Single Indicating Element. – A system with a single indicating element for two or more EVSEs shall be provided with means to display information from the individual EVSE(s) selected or displayed, and shall be provided with an automatic means to indicate clearly and definitely which EVSE is associated with the displayed information.

...

S.2.4.1. Unit Price. – An EVSE shall be able to indicate on each face the unit price at which the EVSE is set to compute or to dispense at any point in time during a transaction.

The indication of the unit price shall be provided via the primary indicating element shall be provided using one or more of the means listed below:

(a) A display device which is integral or adjacent to the EVSE.

b) A device equipped with the means to establish a secure connection to a personal remote/mobile device for display purposes.

(i) The secure connection may be established via wired or wireless means.

(ii) A personal remote/mobile device includes, but is not limited to a smartphone (cell phone), tablet, or laptop computer equipped with a digital display.

(iii) All measuring, indicating and recording elements used in an electric vehicle fueling system shall operate normally while the display application is running on the remote/mobile device.

(iv) The display application running on the remote/personal device shall be freely available and must allow for unannounced inspections by weights and measures officials.

S.1.2.1.(c) Multiple EVSEs Associated with a Single Indicating Element. – A system with a single indicating element for two or more EVSEs shall be provided with means to display information from the individual EVSE(s) selected or displayed, and shall be provided with an automatic means to indicate clearly and definitely which EVSE is associated with the displayed information.

...

S.2.5. EVSE Money-Value Computations. – An EVSE shall indicate **via the primary indicating element** the total sales price at any single purchase unit price for which the electrical energy being measured is offered for sale at any delivery possible within either the measurement range of the EVSE or the range of the computing elements whichever is less.

The primary indicating element shall be provided using one or more of the means listed below:

(a) A display device which is integral or adjacent to the EVSE.

(b) A device equipped with the means to establish a secure connection to a personal remote/mobile device for display purposes.

S.1.2.1.(c) Multiple EVSEs Associated with a Single Indicating Element. – A system with a single indicating element for two or more EVSEs shall be provided with means to display information from the individual EVSE(s) selected or displayed, and shall be provided with an automatic means to indicate clearly and definitely which EVSE is associated with the displayed information.

...

S.2.7. Indication of Delivery. – The EVSE shall automatically show ~~on its face~~ –the initial zero condition and the quantity delivered (up to the capacity of the indicating elements) **via the primary indicating element.**

The primary indicating element shall be provided using one or more of the means listed below:

(a) A display device which is integral or adjacent to the EVSE.

(b) A device equipped with the means to establish a secure connection to a personal remote/mobile device for display purposes.

S.1.2.1.(c) Multiple EVSEs Associated with a Single Indicating Element. – A system with a single indicating element for two or more EVSEs shall be provided with means to display information from the individual EVSE(s) selected or displayed, and shall be provided with an automatic means to indicate clearly and definitely which EVSE is associated with the displayed information

Previous Action:

- N/A

Original Justification:

Technology continues to evolve and more consistently, personal devices are being utilized to display information to consumers regarding commercial transactions whether via transportation network companies or parking meters. It is being recognized that metering systems can be integrated into the technology to ensure the accuracy of the transaction but that the way that information is displayed to the consumer is not directly integrated into the metering system. Under the current language in Handbook 44, the

definition of “face” provides some level of flexibility as it states that “in the case of some electronic displays, this may not be an integral part of the pump or dispenser.” We, however, recommend supplementing the flexibility provided in this language with a clear indication that an electronic remote display can be utilized to meet the primary indicating element requirements for EV charging stations. This electronic remote display could be provided via mobile application, a centralized kiosk or a vehicle user interface. There is precedent for utilizing a mobile application under HB 44, Sec 5.6 for transportation network companies. Charging an EV is a fundamentally different consumer experience than refueling a traditional gas-powered automobile. Where a gas pump can complete a fill-up in a matter of minutes, a charging session can range anywhere from a few minutes to several hours, depending on vehicle type, charging need, and charging power level for direct current fast charging (DCFC) or Level 2. Often, consumers plug in their vehicle and return when the charging session has been completed. The function of a display on the EVSE can be accomplished through the vehicle user interface (UI) and/or through a mobile app, enabling greater reliability and accessibility to the display of information. It is most important to identify the information to be provided to the consumer, require that the EVSE operators provide live session information, and allow for the consumer market to determine which form of communication is most suitable to meet the consumers’ needs, which is increasingly demonstrated to be moving toward personal devices. This would allow companies to innovate new and cost-effective ways of providing information regarding charging sessions including utilizing mobile-app displays as well as in-vehicle displays. Globally, regulators are evaluating measurement needs for EVSE and several countries have already indicated a willingness to utilize a remote display as the primary indicating element. In Germany, via the VDE standard, regulators have enabled a remote display or user interface for compliance so long as the user is receiving the information instantaneously, securely and accurately. The VDE standards can be accessed at <https://www.vde-verlag.de/standards/1400304/e-vde-ar-e-2418-3-100-anwendungsregel-2018-07.html>.

One concern for the mobile app electronic remote display option that may be raised is the security and accuracy of the information on the mobile app and that it matches the meter output data. If there is a physical connection to the meter, plus secure means of wirelessly communicating metering/billing data to the consumer or field inspector, you can verify accuracy securely/confidently via mobile application without needing a screen on the EVSE. The external display has to be correctly registered in the meter to be able to operate securely. To do so, the public key of the display has to be stored in the meter during assembling process, and this 'pairing' process is registered in the metrology log. When meter is using an external display, a charging process can only be started, if the presence, the availability and authenticity of the external display can be verified. The meter signs a list of mandatory metrology registers and an additional set of general metering registers that can be configured during assembly process. These registers are available for transmission as data element to the external Display.

For instance, to verify the information the metering device can have the ability to cryptographically sign every energy reading using a unique digital certificate. Field inspection can then allow for remote validation of digital signatures for each meter reading. Digital signatures can be inspected while connected to the meter directly when performing field validation as well while validating billing records stored remotely i.e. every energy reading that is being billed can be verified to be legitimate. Furthermore, field inspectors could utilize an optical interface to compare the readings of metering data to the displayed data, previously electronically signed and transmitted wirelessly over a secured private network channel to the mobile application without needing a display on the EVSE.

Another concern that may come up is that the operation of certain types of electronic communication in locations such as parking garages and the need for communication to work during an inspection. Utilizing alternate means to establish a secure connection such as local Wi-Fi or Bluetooth, provisions can be put in place to ensure the inspector is able to view the required information with a remote display device during inspection.

There may also be some confusion or concern regarding consumers having to download different apps in order to view the transaction. Consumers already usually choose a few apps for regular use based on the EVSE network they utilize most frequently. For some operators, this information may also be integrated in the vehicle use interface as a closed loop system. It should be noted that the display of the measurement information for the commercial transaction should not be confused with payment systems utilized by the consumer. The type of payment systems available to the consumer are separate from HB 44 Sec 3.4 measurement transaction requirements and should not be conflated.

The submitter requested voting status for this item in 2021.

Comments in Favor:

Regulatory:

-

Industry:

- Supported the item and recommended Developing status.

Advisory:

-

Comments Against:

Regulatory:

- The item should be withdrawn.

Industry:

- Recommended that the item be withdrawn.

Advisory:

- Highlighted some of the concerns that NIST OWM expressed in their analysis.

Neutral Comments:

Regulatory:

-

Industry:

-

Advisory:

-

Item Development:

During the Committee's work session, the committee agreed that the item be withdrawn.

Regional Associations' Comments:

WWMA 2020 Annual Meeting: Ms. Francesca Wahl (Tesla), Mr. Jeremy Whaling (EVgo) and Mr. Brad Juhasz (EVConnect) commented that there is confusion as to where the primary indicator should be located. Technology is rapidly changing, and the movement is towards different formats. This addresses the ability to have the display on mobile devices. Looking at this issue as a global issue rather than US transportation companies. Most customers exit the vehicle while charging and want to be informed real time as to the charging process. Mr. Matthew Douglas (California DMS) stated the indicator should not be a burden to the consumer. The indicating element should be part of the device. If they want additional displays that are appropriate, that's okay, but the primary indicator should be part of the device. Juana Williams (NIST OWM) submitted written comment after open hearings and will be posted on the WWMA website. The Committee agrees, and recommends this item be assigned a developing status.

The Committee also recommends the submitter continue to work with their stakeholders and jurisdictions to develop the item. The Committee further recommends the submitter revise the item to make the primary indicating element be an integral part of the device with any other indicating elements being secondary.

SWMA 2020 Annual Meeting: During the Open Hearings the Committee heard from Ms. Wahl, who stated that the car dash screen or customer's device would be used as the indicator. The Committee has concerns about relying on the customer's device as the only indicator, and issues that could present for the inspection procedure.

After considering this item the Committee recommends that it be given Developing status and developed further by the national work group.

NEWMA 2020 Interim Meeting: The Committee agrees with the body that this item has merit, but due to the emerging technology, more analysis is needed. There are also concerns that charging stations do not have indicators and different vehicle indicators or apps may not be equally effective as measuring tools. Therefore, the Committee recommends this proposal to be considered a Developing item. A comment was heard that the national work group anticipates the display will be app based but has concerns with specific language of open-ended device/display types, such as vehicle user interfaces which may not be as well developed.

CWMA 2020 Interim Meeting: The S&T Committee heard several concerns on this item from regulatory officials. Some of the concerns dealt with the availability of access to the apps/integrated vehicle display at the time of inspection or following up on a consumer complaint. Another concern is the security of the communication between the device and the display. These devices may need to be submitted to NTEP for type evaluation similar to POS systems and software used to generate scale tickets even if they are not the primary indicating element. We feel this item has merit and recommend this item move forward as a Developing item.

Additional letters, presentations and data may have been part of the Committee's consideration. Please refer to <https://www.ncwm.com/publication-16> to review these documents.

| CWMA Report |
|--|
| Comments and justification for the regional recommendation to NCWM: <i>(This will appear in NCWM reports)</i> |
| No comments on withdrawn items. |

EVF-21.4 V S.3.3. Provision for Sealing

Source:

NIST Office of Weights and Measures

Purpose:

In lieu of an electric vehicle fueling system providing a printed copy of its audit trail event records, it should be permissible for those systems that feature either a Category 2 or Category 3 method of sealing metrological features to provide that information in an electronic format during an inspection by weights and measures officials.

Item Under Consideration:

Amend NIST Handbook 44, Electric Vehicle Fueling Systems as follows:

S.3.3. Provision for Sealing. – For devices and systems in which the configuration or calibration parameters can be changed by use of a removable digital storage device, security shall be provided for those parameters as specified in G-S.8.2. Devices and Systems Adjusted Using Removable Digital Storage Devices. For parameters adjusted using other means, the following applies.

Adequate provision shall be made for an approved means of security (e.g., data change audit trail) or physically applying security seals in such a manner that no adjustment can be made of:

- (a) each individual measurement element;
- (b) any adjustable element for controlling voltage or current when such control tends to affect the accuracy of deliveries;
- (c) any adjustment mechanism that corrects or compensates for energy loss between the system and vehicle connection; and
- (d) any metrological parameter that detrimentally affects the metrological integrity of the EVSE or system.

When applicable, the adjusting mechanism shall be readily accessible for purposes of affixing a security seal. Audit trails shall use the format set forth in Table S.3.3. Categories of Device and Methods of Sealing.

(Amended 2019)

| Table S.3.3. Categories of Device and Methods of Sealing | |
|---|---|
| Categories of Device | Method of Sealing |
| <p>Category 1: No remote configuration capability.</p> | <p>Seal by physical seal or two event counters: one for calibration parameters and one for configuration parameters.</p> |
| <p>Category 2: Remote configuration capability, but access is controlled by physical hardware.</p> <p>The device shall clearly indicate that it is in the remote configuration mode and record such message if capable of printing in this mode or shall not operate while in this mode.</p> | <p>The hardware enabling access for remote communication must be on-site. The hardware must be sealed using a physical seal or an event counter for calibration parameters and an event counter for configuration parameters. The event counters may be located either at the individual measuring EVSE or at the system controller; however, an adequate number of counters must be provided to monitor the calibration and configuration parameters of the individual EVSEs at a location. If the counters are located in the system controller rather than at the individual EVSE, means must be provided to generate a hard copy of the information through an on-site device; <u>this information may be provided electronically in lieu of or in addition to a hard copy at the time of inspection.</u></p> |
| <p>Category 3: Remote configuration capability access may be unlimited or controlled through a software switch (e.g., password).</p> <p>The device shall clearly indicate that it is in the remote configuration mode and record such message if capable of printing in this mode or shall not operate while in this mode.</p> | <p>An event logger is required in the device; it must include an event counter (000 to 999), the parameter ID, the date and time of the change, and the new value of the parameter. A printed copy of the information must be available through the EVSE or through another on-site device. <u>The event logger information may be provided electronically in lieu of or in addition to a hard copy at the time of inspection, provided the event logger information is retained in the system for future reference.</u> The event logger shall have a capacity to retain records equal to 10 times the number of sealable parameters in the EVSE, but not more than 1000 records are required. (Note: Does not require 1000 changes to be stored for each parameter.)</p> |

(Amended 2021)

Previous Action:

- N/A

Original Justification:

Requiring EVSE operators to provide printed audit trail event information at each location, as is prescribed in Table S.3.3. becomes unduly onerous without providing any commensurate benefit that could not be met by digital means. Most EVSE operators do not employ staff at EVSE stations, so housing printer materials on site and ensuring their replenishment is not reasonable. Devices shall be designed so that inspectors are able to easily access audit trail event records in a usable format. Weights and measures officials could ensure that the intent of this requirement is met through a specification included in Table S.3.3. that requires event information be made available at the time of inspection so that an official needing to make enforcement decisions can do so irrespective of whether an EVSE provides those records in digital or hard copy format.

On August 10, 2020 the Electric Vehicle Fueling Equipment (EVFE) Subgroup, which is part of the USNWG EVF&S, agreed the proposal should move forward for adoption in 2021. The EVFE Subgroup plans to continue its work to refine and fully develop legal metrology requirements and test procedures for EVSEs.

The submitter requested voting status for this item in 2021.

Comments in Favor:

Regulatory:

- Recommend Voting status.

Industry:

- Recommend Voting status.

Advisory:

- Update on the NIST OWM analysis.

Comments Against:

Regulatory:

-

Industry:

-

Advisory:

-

Neutral Comments:

Regulatory:

-

Industry:

-

Advisory:

-

Item Development:

The committee supported this item and agreed to a Voting status for this item.

Regional Associations' Comments:

WWMA 2020 Annual Meeting: Mr. Kevin Schnepf (California DMS) commented that California is in support of this item. It recognizes the changes of tech and will not have to add any costs of having a physical printer on the device. Ms. Tina Butcher (NIST OWM) commented that this item originated from the national working subgroup. This is a desire to move to alternative formats. The group recognizes this is the way of the future. It also recognizes these types of installations do not have people on site. W&M inspectors may be impeded during their inspection. The General Code allows the owner to assist. Mr. Mahesh Albuquerque (Colorado) supports this item.

The Committee agrees the item is fully developed and recommends assigning this item a Voting status.

SWMA 2020 Annual Meeting: During Open Hearings the Committee heard from Alan Walker (Florida) who asked for clarification on sealing these devices. The Committee also heard from Dianne Lee (OWM) who stated that NIST supported moving this forward as a Voting Item. She also stated that the Subgroup consensus was to permit an electronic event log.

After considering this item the Committee recommends the item move forward as a Voting Item.

NEWMA 2020 Interim Meeting: The Committee agrees with the body that this proposal be considered a Voting Item. This item was submitted by NIST on behalf of the national work group, which believed it was fully developed and ready to be voted on. There is some concern that the electronic logger may provide an imposition for W&M inspectors that do not have a smart phone/laptop/internet service, but the User Requirement of assistance from the device owner should resolve any concerns. LMD 21.1 has a similar proposal and should have language aligned for the sake of consistency.

CWMA 2020 Interim Meeting: The only comments heard by the S&T committee on this item were from Ms. Butcher (NIST OWM). She advised that this item has come out of the work of the USNWG EVF&S and is fully developed and recommended this item for Voting status. The Committee agrees.

Additional letters, presentations and data may have been part of the Committee’s consideration. Please refer to <https://www.ncwm.com/publication-16> to review these documents.

| CWMA Report |
|--|
| Comments and justification for the regional recommendation to NCWM: <i>(This will appear in NCWM reports)</i> |
| Juana Williams (NIST OWM) Provided background and technical information on this item. OWM feels this item is fully developed and is ready to be voted on. The USNWG has reached consensus and believes this item is ready for a vote. The CWMA S&T Committee recommends that this item be moved to a voting item. |

EVF-21.5 W T.2. Load Test Tolerances.

Source:

ABB, BTCPower, Electrify America, Edison Electric Institute, EVConnect, EVgo, Greenlots, Rivian, Siemens, Tesla, Tritium

Purpose:

to create separate metering requirements for DC EVSE due to significant technology differences and challenges between AC and DC systems.

Item Under Consideration:

Amend Handbook 44, Electric Vehicle Fueling Systems as follows:

T.2. Load Test Tolerances.

T.2.1. AC EVSE Load Test Tolerances. – The tolerances for AC EVSE load tests are:

- (a) Acceptance Tolerance: 1.0 %; and
- (b) Maintenance Tolerance: 2.0 %.

T.2.2. DC EVSE Load Test Tolerances. – **The tolerances for DC EVSE load tests:**

- (a) **Devices installed prior to January 1, 2033**
 - i. **Acceptance Tolerance: 2.5 %; and**
 - ii. **Maintenance Tolerance: 5.0 %**
- (b) **Devices installed January 1, 2033 or later**
 - i. **Acceptance Tolerance: 1.0 %; and**
 - ii. **Maintenance Tolerance: 2.0 %**

Previous Action:

- N/A

Original Justification:

Proposed changes to the text to differentiate alternating current (AC) EVSE from direct current (DC) EVSE. Metering for DC architected systems is considerably more complicated and in ways that the original drafting of this provision never contemplated. For example, the tentative code when initially written never contemplated 350kW EVSE or liquid cooled cabling from the charging post to the connector. As such, it is necessary to separate the implementation dates of some of the specifications, tolerances, and other technical requirements. DC metering solutions are still being researched and developed and are not yet commercially available to be integrated into DC chargers at scale and at reasonable cost. While the supply chain for the physical meters themselves is slowly catching up, the metering system in a DC EVSE, particularly high-power DC EVSE that utilize liquid-cooled cables, goes beyond the physical meter itself which is incorporated in the main housing of the EVSE. For example, measurements may also need to be taken at the connector end of the dispenser and software and algorithms must be developed, validated, and integrated into the EVSE system to allow for accurate metering of kWh delivered to the vehicle. Implementing more complex metering systems needed for DCFC requires significant design and manufacturing changes to DC EVSE.

The proposed tolerances account for the fact that these systems are still in development and are untested. The proposed timeline provides the industry with enough time to develop, test, validate, and deploy reliable DC metering system technology. This timeline is also consistent with the timeline approved by the State of California which accounts for the vast majority of the EVSE market. EVSE manufacturers are working diligently to meet the California timeline and are confident that it can be met.

While it is important to ensure that consumers are receiving accurate and transparent information regarding the accuracy of EV charging stations, it is also important that the technology to deliver high accuracy is available and reliable.

There is concern about both the proposed timeline and the accuracy requirement. Some are concerned that the accuracy specification of 2.5% acceptance and 5% maintenance is too high and does not provide sufficient consumer confidence that all charge sessions are equal regardless of provider and station. The proposers would note that this is a new and evolving technology where charging providers place a premium on customer experience as they compete for this growing market. Thus far, customers have not registered complaints about lack of transparency. Some are concerned that the timeline for instituting a metering regime is too far into the future. The proposers acknowledge the few years it will take to have reliable DC metering systems commercially available at scale but are working as quickly as possible to develop and integrate these systems into their chargers. Some are also concerned that the metering requirements have been in a place for several years already and therefore the EVSE community should not need more years to develop solutions. The proposers note that current DC EVSE technology was never contemplated by the existing metering regime and DC technology, particularly high-power DC EVSE, were not in existence at the time the original specifications were set. For example, the first 350kWh EVSE with liquid cooled cables weren't deployed in the US until 2018.

The submitter requested voting status for this item in 2021.

Comments in Favor:

Regulatory:

- Recommended Developing status.

Industry:

- Supported the item and recommended Developing status.

Advisory:

-

Comments Against:

Regulatory:

-

Industry:

- Recommended that the item be withdrawn because their devices meet the current tolerances.

Advisory:

-

Neutral Comments:

Regulatory:

-

Industry:

-

Advisory:

-

Item Development:

the committee agreed to a Developing status for this item.

Regional Associations' Comments:

WWMA 2019 Annual Meeting: During the open hearings for these items a presentation by Tesla, EVConnect and EVgo was given in which a slide spoke to this item stating the need to separate the requirements for AC and DC systems. Extending the tolerances based on the extension of time allowing time for higher accuracy phase in. Kevin Schnepf (CA DMS) believes the phase in for tighter tolerances may be too long. Accuracy will become a greater issue as this becomes more prevalent. Clarification needs to be made; the submitter references public access; we deal with commercial use. The term public access should be changed to commercial use. Also, with technology changing so rapidly, 13-year phase in period is too long. Kurt Floren (LA County) agrees with Kevin's comments. Tina Butcher (NIST OWM) agrees with Kevin and consumers generally expect the tolerances be the same. Look at a shorter period of time to avoid consumer confusion.

The Committee agrees, and recommends this item be assigned a Developing status. The Committee also recommends the submitter continue to work with their stakeholders and jurisdictions to develop the item. The Committee further recommends the submitter provides additional data beyond their original justification to support the necessity for two separate tolerances.

SWMA 2019 Annual Meeting: During the Open Hearing the Committee heard from Ken Ramsburg (Maryland) who stated that he would like real world data before determining the tolerances. He also stated that the proposed tolerance is more than double the current tolerance.

After considering this item the Committee recommends this item be given Developing status and be developed further by the national work group.

NEWMA 2019 Interim Meeting: The Committee agrees with the body that this item has no merit as there is lack of data. The Committee recommends that the proposal be Withdrawn. During open hearings, the Committee heard comments that the national work group could not come to a consensus on this item. There are concerns that consumers would be unaware of different devices in the same category operating on different tolerances. More data needs to be offered to show accuracy capabilities. Tolerance parameters set until 2033 is too distant for this fast-paced technological field that is rapidly changing.

CWMA 2020 Interim Meeting: The S&T Committee heard concerns from regulatory officials that this item does not have a sunset date, so devices installed prior to January 1, 2033 would be allowed a higher tolerance for the life of those devices. The Committee also heard comments that a limited amount of data was available to support the higher tolerances. We feel that this item has merit and recommend it move forward with a Developing status.

Additional letters, presentations and data may have been part of the Committee's consideration. Please refer to <https://www.ncwm.com/publication-16> to review these documents.

| |
|--------------------|
| CWMA Report |
|--------------------|

1

Comments and justification for the regional recommendation to NCWM: (This will appear in NCWM reports)

Juana Williams (NIST OWM) Provided background and technical information on this item. The question was raised about the number of DC devices versus the number of AC device currently in the marketplace. Can the DC devices already in the marketplace meet the current tolerances? A marking on the device indicating the dual tolerance use be on the dispenser. The proposal needs to have a “sunset” date for the higher tolerances. Charlie Stutesman (KS) believes this item should be withdrawn as it provides too long of a time period before devices have to comply. The CWMA S&T Committee recommends that this item be withdrawn.

2 **EVF-21.6 V Definitions: minimum measured quantity (MMQ)**

3 **Source:**

4 NIST Office of Weights and Measures

5 **Purpose:**

6 Include the term “minimum measured quantity (MMQ)” in the NIST Handbook 44 Section 3.40 Electric Vehicle
7 Fueling Systems –Tentative Code Definitions. The term has special meaning for these systems and is missing from
8 the code’s definitions. The term is applicable to these systems because it is a unique marking requirement and its
9 value is used in the determination of test loads and tolerances.

10 **Item Under Consideration:**

11 Amend Handbook 44, Section 3.40 as follows:

12 **minimum measured quantity (MMQ). – The smallest quantity delivered for which the measurement is to**
13 **within the applicable tolerances for that system. [3.37, 3.39, 3.40]**

14 **Previous Action:**

- 15 • N/A

16 **Original Justification:**

17 The current Handbook 44, Appendix D-Definitions define the term “minimum measured quantity (MMQ).” The
18 MMQ represents the smallest quantity at which the manufacturer declares a system is suitable for a delivery and will
19 remain in compliance. The term MMQ appears in the requirements in only three NIST HB 44 codes (3.37, 3.39, and
20 3.40).

21 In 2014 the U.S. National Work Group (USNWG) on Electric Vehicle Fueling and Submetering (EVF&S) developing
22 HB 44 Section 3.40 EVFS-Tentative Code inadvertently omitted the term MMQ from the code’s Definitions. The
23 MMQ is required marking information on these systems and the official uses the MMQ value in the determination of
24 test loads and tolerances. MMQ has a special meaning for electric vehicle fueling systems (EVFS) and is cited eleven
25 times in the following Section 3.40 code paragraphs: S.4.2. Directional Control; S.5.2. (d) EVSE Identification and
26 Marking Requirements; S.8. Minimum Measured Quantity (MMQ); N.3. Minimum Test Draft (Size); N.5.2. Accuracy
27 Testing (AC and DC Systems); and T.4. Tolerance Application in Type Evaluation Examinations for EVSEs. To
28 remedy the omission of the term in the Appendix D Definitions for Section 3.40 and to clarify the term is also
29 applicable to EVFSs the definition of MMQ should be included in the code’s appendix and the brackets include the
30 code section’s numerical designation 3.40.

31 On August 10, 2020 the Electric Vehicle Fueling Equipment Subgroup, which is part of the USNWG EVF&S, agreed
32 the proposal should move forward for adoption in 2021.

33 This proposal is a housekeeping item correcting the omission of a definition for the term “minimum measured
34 quantity” that should have appeared in NIST HB 44 Section 3.40 EVFS-Tentative Code when the code was first
35 published in 2016. The EVFS code has tentative status and to date no equipment has undergone the type evaluation
36 process. It is anticipated there will be slight modifications to this code’s requirements and test procedures to address
37 various generations of equipment, design configurations, and business models in the marketplace. At some point it is

1 even possible that further parameters will be developed to simplify the process for establishing an appropriate value
2 for the MMQ for all types of EVFSs over a wide range of power capacities. For now, the MMQ currently cited in the
3 EVFS design, test notes, and tolerance requirements in Section 3.40 should be clearly defined for these systems

4 The submitter requested voting status for this item in 2021.

5 **Comments in Favor:**

6 **Regulatory:**

- 7 •

8 **Industry:**

- 9 •

10 **Advisory:**

- 11 • Comments included in the NIST OWM Analysis.
12 • Definitions are included in the tentative code until the code is made permanent, at which time they will
13 be moved to Appendix D in Handbook 44.

14 **Comments Against:**

15 **Regulatory:**

- 16 •

17 **Industry:**

- 18 •

19 **Advisory:**

- 20 •

21 **Neutral Comments:**

22 **Regulatory:**

- 23 •

24 **Industry:**

- 25 •

26 **Advisory:**

- 27 •

28 **Item Development:**

29 N/A

30 **Regional Associations' Comments:**

31 WWMA 2020 Annual Meeting: Tina Butcher (NIST OWM) commented, they think it's a housekeeping item, not
32 technically substantial. There has been some discussion in the national working group as to whether the MMQ is
33 relevant. But this is only dealing with the definition.

34 The Committee agrees this item is fully developed and recommends a Voting status. The Committee noted that an
35 editorial correction needs to be made removing the word "to".

1 SWMA 2020 Annual Meeting: During the Open Hearing the Committee heard from Dianne Lee who stated that NIST
 2 supported moving this item forward as a Voting Item.

3 After considering this item the Committee recommends that it be given Developing Status and be developed further
 4 by the national work group.

5 NEWMA 2020 Interim Meeting: The Committee agrees with the body that this proposal should be considered a
 6 Voting Item. This item was submitted by NIST and supported by the national work group. There is an error in the
 7 agenda and the item under consideration should read section 3.40, not Appendix D. This item duplicates the definition
 8 in Appendix D and provides a needed definition for a term being used (MMQ) within the tentative code. The item
 9 received no opposition during the open hearing.

10 CWMA 2020 Interim Meeting: The only comments received by the S&T committee were from Tina Butcher (NIST
 11 OWM). She explained that this item is to correct an inadvertent omission to the EVFS code. She also advised that
 12 the submitted item should be changed as follows to add this definition to the EVFS code and not Appendix D.

13 **Item Under Consideration:**

14 Amend NIST Handbook 44 NIST, Section 3.40. Definitions as follows:

15 **minimum measured quantity (MMQ). – The smallest quantity delivered for which the**
 16 **measurement is to within the applicable tolerances for that system. [3.37, 3.39, 3.40]**

17 We feel that this item is fully developed with the change made above and recommend this item move forward as a
 18 Voting item.

19 Additional letters, presentations and data may have been part of the Committee’s consideration. Please refer to
 20 <https://www.ncwm.com/publication-16> to review these documents.

| CWMA Report |
|---|
| Comments and justification for the regional recommendation to NCWM: <i>(This will appear in NCWM reports)</i> |
| Juana Williams (NIST OWM) Provided background and technical information on this item. When Section 3.40 was published, this definition was overlooked. This is correcting the oversight. OWM believes this is fully developed and ready for a vote. The CWMA S&T Committee recommends that this item remain a Voting item. |

21 **TXI – TAXIMETERS**

22 **See Block 3 Items: Tolerances for Distance Testing.**

23 **GMA – GRAIN MOISTURE METERS 5.56 (A)**

24 **GMA-19.1 D Table T.2.1. Acceptance and Maintenance Tolerances Air Oven Method for All**
 25 **Grains and Oil Seeds.**

26 **Source:**

27 NTEP Grain Analyzer Sector

28 **Purpose:**

29 Reduce the tolerances for the air oven reference method.

1 **Item Under Consideration:**
 2 Amend Handbook 44, Grain Moisture Meter Code 5.56 (a) as follows:

3 **T.2.1. Air Oven Reference Method.** – Maintenance and acceptance tolerances shall be as shown in
 4 Table T.2.1. Acceptance and Maintenance Tolerances Air Oven Reference Method. Tolerances are expressed as
 5 a fraction of the percent moisture content of the official grain sample, together with a minimum tolerance.
 6 (Amended 2001)

| Table T.2.1. Acceptance and Maintenance Tolerances Air Oven Reference Method | | |
|---|---|--------------------------------------|
| Type of Grain, Class, or Seed | Tolerance | Minimum Tolerance |
| Corn, oats, rice, sorghum, sunflower | 0.05 of the percent moisture content | 0.8 % in moisture content |
| All other cereal grains and oil seeds | 0.04 of the percent moisture content | 0.7 % in moisture content |

| Table T.2.1. Acceptance and Maintenance Tolerances Air Oven Reference Method for All Grains and Oil Seeds | |
|--|---|
| <u>Tolerance</u> | <u>Minimum Tolerance</u> |
| <u>0.03 of the percent moisture content</u> | <u>0.5 % in moisture content</u> |

(Amended 2001 **and 20XX**)

7
 8 **Background/Discussion:**
 9 This item has been assigned to the submitter for further development. For more information or to provide comment,
 10 please contact:

11 Mr. Karl Cunningham
 12 Illinois Department of Agriculture
 13 217-785-8301, karl.cunningham@illinois.gov

14 Samples and list of grains that AMS, FGIS request from states to include in their ongoing calibration program. States
 15 and other interested parties wanted to verify that corn samples from their state were included in the calibration data
 16 for NTEP meters because of variations states reported between UGMA meter and other meter technologies on corn
 17 samples.

18 During the 2016 Grain Analyzer Sector Meeting, numerous instances of inconsistent moisture meter measurements
 19 involving grain shipments from U.S. interior facilities to U.S. export port facilities were reported. The Sector received
 20 a suggestion that if the UGMA can make better measurements, then the Sector should consider reducing the applicable
 21 tolerances in NIST HB 44. At the 2016 and 2017 Grain Analyzer Sector meetings Mr. Charlie Hurburgh (Iowa State
 22 University) agreed to chair a GA Sector Task Group to review the current NIST HB 44 tolerance with both UGMA
 23 meters and Non-UGMA meters. During the 2018 meeting Mr. Hurburgh reported that based on data he analyzed from
 24 Iowa State Weights and Measures Grain Inspection reports, UGMA meters read closer to the reference air oven
 25 moisture results than non-UGMA meters.

1 It was also noted during the 2018 NTEP Grain Analyzer Sector meeting that the current tolerances were developed in
 2 1991 and have not been changed to coincide with the change in technology for these devices; and this action is needed
 3 for grain industry risk management.

4 Prior to the 2019 NCWM Interim Meeting, all four regional weights and measures associations agreed to forward the
 5 proposal as a voting item on the Interim Agenda. However, following the regional meetings, additional data was
 6 submitted to the Sector which indicates a need to consider developing different tolerance for some grain types.
 7 Through a subsequent ballot, and a majority vote, the Sector agreed to recommend changing the status of the item to
 8 developing to provide the Sector time to consider additional data and changes to its original proposal.

9 2019 NCWM Interim Meeting: The NCWM S&T Committee heard comments to agenda item GMA-3. Mr. Loren
 10 Minnich (KS) commented that he spoke with Ms. Diane Lee (NIST OWM) and she reported that one state was
 11 concerned with the application of the reduced tolerances to all grain types, specifically grains with hulls or husks. He
 12 suggested that this item be assigned a “Developing” status to allow for more research into this issue. The committee
 13 also received written comments from NIST, OWM (see NIST, OWM Analysis posted on the NCWM Website).
 14 During the 2019 Interim Meeting, the S&T Committee considered the comments during the opening hearing and
 15 comments submitted prior to the meeting and assigned a “Developing” status for this item.

16 2019 NCWM Annual Meeting: Ms. Diane Lee (NIST OWM) provided an update on the history of the item. She
 17 noted that the GA Sector will review data from Arkansas at its 2019 meeting intended to assure that proposed changes
 18 to the tolerances can be applied to all grains. Ms. Lee speaking on behalf of the Sector stated that the Developing
 19 status assigned to this item is appropriate.

20 2020 NCWM Interim Meeting: The Committee heard from Ms. Diane Lee (NIST OWM) who stated that when this
 21 item was initially submitted the GMM Sector agreed to reduce tolerance based on data that was limited to corn and
 22 soybeans. Following the review of the initial data, additional data from Long Grain Rough Rice was reviewed and
 23 the sector agreed that additional data was needed on other grains to include oats, rice and barley, prior to changing the
 24 tolerances. Ms. Lee requested that the item remain developing status as additional data is collected.

25 During the Committee’s work session, the committee agreed to retain this item as Developing to allow the submitter
 26 to continue working with members of the grain analyzer sector to collect additional data.

27 2020 NCWM Annual Meeting: Due to the 2020 Covid-19 pandemic, this meeting was adjourned to January 2021, at
 28 which time it was held as a virtual meeting. Due to constraint of time, only those items designated as 2020 Voting
 29 Items were addressed. All other items were addressed in the subsequent 2021 NCWM Interim Meeting.

30 2021 NCWM Interim Meeting: The committee heard comments from Ms. Diane Lee (NIST OWM) who noted that
 31 additional data is needed to assess the proposed tolerances. Ms. Lee requested that this item remain Developing.

32 During the Committee’s work session, the Committee agreed to a Developing status for this item

33 **Regional Association Comments:**

34 WWMA 2019 Annual Meeting: Mr. Russ Vires (SMA) stated the SMA takes no position on this item and looks
 35 forward to additional analysis by the submitter.

36 The Committee agrees the item has merit however, based on input provided from the NTEP Grain Analyzer Sector
 37 there will be additional data provided to the Committee prior to the 2020 NCWM Interim Meeting. The Committee
 38 agrees the item should be designated as a Developing item.

39 SWMA 2019 Annual Meeting: Mr. Russ Vires (SMA) stated he had no position on this item. Ms. Diane Lee (NIST
 40 OWM) stated that nationwide testing on more grains would be taking place to aid in any tolerance change
 41 determinations. She recommended this item remain Developing. The Committee recommends this item to remain a
 42 Developing Item so that more detailed tolerances can be determined.

1 NEWMA 2019 Interim Meeting: The Committee and the body agree that this item should continue as a Developing
2 item. No comments were heard during open hearings.

3 CWMA 2020 Interim Meeting: The S&T Committee heard comments from G. Diane Lee (NIST OWM) giving an
4 update from the NTEP Grain Analyzer Sector work on this item and requested this item remain developing so they
5 can complete their work on this item. The Committee recommends this item remain with a Developing status.

6 Additional letters, presentation and data may have been submitted for consideration with this item. Please refer to
7 <https://www.ncwm.com/publication-16> to review these documents.

| CWMA Report |
|---|
| Regional recommendation to NCWM on item status: XX Recommend as a Developing Item on the NCWM agenda <i>(To be developed by source of the proposal)</i> |
| Comments and justification for the regional recommendation to NCWM: <i>(This will appear in NCWM reports)</i> Diane Lee (NIST OWM) gave an update on the need for additional data on other grains. OWM recommends that this item remain developing. The CWMA S&T Committee recommends that this item remains Developing. |

8 **BLOCK 3 ITEMS (B3) TOLERANCES FOR DISTANCE TESTING IN TAXIMETERS**
9 **AND TRANSPORTATION NETWORK SYSTEMS**

10 **Source:**
11 New York Department of Agriculture and Markets

12 **Purpose:**
13 Provide the same distance-measurement tolerances for the Taximeters Code and Transportation Network Systems
14 Code.

15 **B3: TXI-20.1 w T. Tolerances**

16 **Item Under Consideration:**
17 Amend Handbook 44, Taximeters Code as follows:

18 **T. Tolerances**

19 **T.1. Tolerance Values.**

20 **T.1.1. On Distance Tests.** – Maintenance and acceptance tolerances for taximeters shall be as follows:

21 (a) On Overregistration: 1 % of the interval under test **when the distance is 1.6 km (1 mile) or less.**
22 **2.5 % of the interval under test when the distance is greater than 1.6 km (1 mile).**

23 **B3: TNS-20.1 W T. Tolerances**

24 **Item Under Consideration:**
25 Amend NIST Handbook 44, Transportation Network Systems Code as follows:

26 **T. Tolerances**

1 **T.1.1. Distance Tests.** – Maintenance and acceptance tolerances shall be as follows:

2 (a) On Overregistration: ~~2.5%~~ **1 % of the interval under test when the distance is 1.6 km (1 mile)**
 3 **or less. 2.5 % of the interval under test when the distance is greater than 1.6 km (1 mile).**

4 (b) On Underregistration: ~~2.5%~~ **4 % of the interval under test.**

5 **Background/Discussion:**

6 This item has been assigned to the submitter for further development. For more information or to provide comment,
 7 please contact:

8 Mr. Jim Willis
 9 New York Department of Agriculture and Markets
 10 518-485-8377, james.willis@agriculture.ny.gov

11 Taximeter manufacturers are submitting devices identical to the devices in the Transportation Network Measurement
 12 Systems code; however, they are faced with a tighter tolerance for over-registration. Both devices are typically
 13 computer pads or cell phones. Taximeter companies want to take advantage of some of the same technology used by
 14 TNMS companies, however, the tolerance for taximeters is much tighter than the tolerance for TNMS meters. During
 15 type evaluation, it is common to drive more than 1 mile to incorporate tunnels and valley effect. If the same tolerance
 16 was applied, taximeters would have the same chance of passing as TNMS meters.

17 Some jurisdictions that test taximeters may not want the tolerance for a 1-mile course to be raised given the good
 18 history of their test programs. This is the reason I am proposing maintaining the 1 % tolerance at 1 mile or less.

19 Some TNMS companies may be concerned that their device will not pass a 1 % tolerance, but we believe that on a
 20 straight, 1-mile course, devices operating properly should have no problem passing.

21 2020 NCWM Interim Meeting: The Committee heard from NIST OWM explaining that the proposal is not technically
 22 correct by inserting language that refers to “intervals” in the tentative HB 44 TNMS Code. These types of systems
 23 do not calculate a charge for fare using intervals (i.e., segments) of the total travel in a trip as do taximeters. TNMS
 24 calculate fare charges based on the entire distance/time in a trip. Additionally, these two different systems (taximeters
 25 and TNMS) are becoming more similar and the differences that were used to distinguish them from one another are
 26 beginning to fade. OWM noted there is a need for the USNWG on Taximeters that developed the tentative TNMS
 27 Code to meet and discuss the potential of a merger of these two HB 44 Codes. Mr. Kurt Floren (Los Angeles County,
 28 California.) pointed out that taximeters have been and still are meeting existing tolerances and therefore he questions
 29 the need to expand those tolerance values.

30 Mr. Stan Toy (Santa Clara County, California) expressed his belief that the tolerances for taximeters do not need to
 31 be expanded and that this item should be withdrawn. Mr. Jim Willis (New York) pointed out that New York Weights
 32 and Measures has issued its own type approval for taximeters that use location services such as GPS to measure
 33 distance. He stated further that NY would support a Developing or Assigned status.

34 During the Committee’s work session, it was agreed to assign a Developing status with the understanding the USNWG
 35 on Taximeters has offered to assist the submitter in further development of the proposal.

36 2020 NCWM Annual Meeting: Due to the 2020 Covid-19 pandemic, this meeting was adjourned to January 2021, at
 37 which time it was held as a virtual meeting. Due to constraint of time, only those items designated as 2020 Voting
 38 Items were addressed. All other items were addressed in the subsequent 2021 NCWM Interim Meeting.

39 2021 NCWM Interim Meeting: Mr. John Barton (NIST OWM) stated that OWM noted issues of concern in this proposal
 40 during the 2020 NCWM Interim Meeting regarding how tolerances are applied to taximeters in contrast to how they are
 41 applied to TNMS. This proposal does not seem to recognize these differences. OWM also notes the many opposing
 42 comments made pertaining to the increase of tolerances for taximeters which have complied with existing tolerances for
 43 decades. The NIST USNWG on Taximeters has been conducting meetings with a goal of merging the HB 44 Taximeters
 44 and TNMS Codes. This work will include a number of modifications to both codes that will affect the specifications, test

CWMA S&T 2021 Annual Meeting Report

1 procedures, user requirements, and possibly the tolerances. The USNWG has offered to work with the submitter of this
2 proposal.

3 Mr. Willis representing the submitter of this item stated a willingness to work the USNWG on Taximeters.

4 During the committee’s work session, the members noted the submitter’s willingness to work with the taximeter work
5 group and agreed to maintain this item’s Developing status.

6 **Regional Association Comments:**

7 WWMA 2019 Annual Meeting: Mr. John Barton (NIST OWM) stated that the effort to align the TNMS Code with
8 the Taximeters Code is appreciated and expressed the desire to merge the two codes in the future. Mr. Kurt Floren
9 stated that he has concerns about the significant increase in the tolerance allowed for taximeters as proposed and that
10 there is no data to support such a change. Mr. Clark Cooney (California) stated that he agrees with Mr. Floren and
11 encourages further development of this proposal. Mr. Stan Toy (Santa Clara County, California) stated that he agrees
12 with the previous comments heard and does not believe the tolerances for taximeters should be increased.

13 The WWMA agrees that the item should be given a Developing status and that the submitter should work with the
14 USNWG on Taximeters to incorporate the proposed changes into the appropriate HB 44 Codes.

15 SWMA 2019 Annual Meeting: The SWMA heard no comments on this item. The SWMA decided to make No
16 Recommendation.

17 NEWMA 2019 Interim Meeting: The NEWMS and the body agree that this item should be moved to voting status.
18 During open hearings, Mr. Jim Willis (NY) indicated that taximeters are currently being held to tighter standard as
19 compared to TNS and this proposal will align the tolerances in both codes. Mr. John McGuire (NJ) and Mr. James
20 Cassidy (MA), voiced support.

21 2020 Regional Meetings of the WWMA, NEWMA, and SWMA: These regions adhered to a condensed agenda due
22 to the Covid pandemic and did not consider this item.

23 2020 CWMA Annual Meeting: The CWMA heard from a single commenter, Mrs. Tina Butcher (NIST OWM). She
24 gave an update of the work of the USNWG and requested these items remain as developing items. The CWMA agreed
25 and recommends a Developing status.

26 Additional letters, presentations and data may have been part of the Committee’s consideration. Please refer to
27 <https://www.ncwm.com/publication-16> to review these documents.

| CWMA Report |
|---|
| Comments and justification for the regional recommendation to NCWM: <i>(This will appear in NCWM reports)</i> |
| Comments taken on the whole block John Barton (NIST OWM) provided comments. It is not necessary to increase tolerances on taxi meters. The taxi meters have been meeting these for decade. This addresses transportation network system primarily and adjustments to tolerances are being made to both codes. The practice of measuring intervals for taximeters is not followed when measuring distances in TNS. The USNWG is looking at possibly combining Taximeters and TNS into a single code. In order for this item to move forward it will need to be reworked. The submitter has agreed to work with the USNWG. The CWMA S&T Committee recommends that this Item Block be Withdrawn. |

1 **OTH – OTHER ITEMS**

2 **OTH-16.1 D Electric Watthour Meters Code under Development**

3 **Source:**
4 NIST OWM

5 **Purpose:**

- 6 1) Make the weights and measures community aware of work being done within the U.S. National Work Group
7 on Electric Vehicle Fueling and Submetering to develop proposed requirements for electric watthour meters
8 used in submeter applications in residences and businesses;
- 9 2) Encourage participation in this work by interested regulatory officials, manufacturers, and users of electric
10 submeters.
- 11 3) Allow an opportunity for the USNWG to provide regular updates to the S&T Committee and the weights and
12 measures community on the progress of this work;
- 13 4) Allow the USWNG to vet specific proposals as input is needed.

14 **Item Under Consideration:**

15 Create a “Developing Item” for inclusion on the NCWM S&T Committee Agenda where progress of the USNWG
16 can be reported as it develops legal metrology requirements for electric watthour meters and continues work to develop
17 test procedures and test equipment standards. The following narrative is proposed for this item:

18 In 2012, NIST OWM formed the U.S. National Working Group on Electric Vehicle Fueling and Submetering to
19 develop proposed requirements for commercial electricity-measuring devices (including those used in sub-
20 metering electricity at residential and business locations and those used to measure and sell electricity dispensed
21 as a vehicle fuel) and to ensure that the prescribed methodologies and standards facilitate measurements that are
22 traceable to the International System of Units (SI).

23 In 2013, the NCWM adopted changes recommended by the USNWG to the NIST Handbook 130 requirements
24 for the Method of Sale of Commodities to specify the method of sale for electric vehicle refueling. At the 2015
25 NCWM Annual Meeting, the NCWM adopted NIST Handbook 44 Section 3.40 Electric Vehicle Refueling
26 Systems developed by the USNWG.

27 This Developing Item is included on the Committee’s agenda (and a corresponding item is proposed for inclusion
28 on the L&R Committee Agenda) to keep the weights and measures community apprised of USNWG current
29 projects, including the following:

- 30 • The USNWG continues to develop recommended test procedures for inclusion in a new EPO 30 for
31 Electric Vehicle Refueling Equipment along with proposed requirements for field test standards.
- 32 • The USWNG is continuing work to develop a proposed code for electricity-measuring devices used in sub-
33 metering electricity at residential and business locations. This does not include metering systems under
34 the jurisdiction of public utilities. The USNWG hopes to have a draft code for consideration by the
35 community in the 2019-2020 NCWM cycle.

36 The USNWG will provide regular updates on the progress of this work and welcomes input from the community.
37 For additional information, contacts for the subgroups of the USNWG are:

38 **Electric Vehicle Refueling Subgroup:**

- 39 • Chairman, Tina Butcher at tbutcher@nist.gov or (301) 975-2196
40 • Technical Advisor, Juana Williams at juana.williams@nist.gov or (301) 975-3989

41 **Electric Watthour Meters Subgroup:**

- 42 • Chairman, Lisa Warfield at lisa.warfield@nist.gov or (301) 975-3308

1 Technical Advisor, Tina Butcher at tbutcher@nist.gov or (301) 975-2196

2 **Background/Discussion:**

3 This item has been assigned to the submitter for further development. For more information or to provide comment,
4 please contact:
5

Electric Vehicle Refueling Subgroup:

Ms. Tina Butcher, Chair
NIST Office of Weights and Measures
301-975-2196, tbutcher@nist.gov
Or
Ms. Juana Williams, Technical Advisor
NIST Office of Weights and Measures
301-975-2196, juana.williams@nist.gov

Electric Watthour Meters Subgroup:

Ms. Lisa Warfield, Chair
NIST Office of Weights and Measures
301-975-3308, lisa.warfield@nist.gov
Or
Ms. Tina Butcher, Technical Advisor
NIST Office of Weights and Measures
301-975-2196, tbutcher@nist.gov

6 This item was submitted as a Developing item to provide a venue to allow the USNWG to update the weights and
7 measures community on continued work to develop test procedures and test equipment standards within its Electric
8 Vehicle Refueling Subgroup. This item will also serve as a forum in which to report work on the development of a
9 proposed tentative code for electric watthour meters in residential and business locations by the USNWG's Electric
10 Watthour Meters Subgroup and a placeholder for its eventual submission for consideration by NCWM.

11 Ms. Tina Butcher (NIST OWM), Chairman of the USNWG on Electric Refueling & Submetering has continued to
12 provide regular updates to the Committee on this work. See the Committee's 2016 through 2018 Final Reports for
13 details.

14 2018 NCWM Interim Meeting: No comments were heard on this item and the Committee agreed to maintain its
15 "Developing" status. The Committee did not take comments during open hearings on Developing items at the 2018
16 NCWM Annual Meeting and agreed to allow only the submitter of a Developing item (or block of Developing items)
17 to provide an update on the progress made to further develop the item(s) since the 2018 NCWM Interim Meeting. The
18 Committee received an update on this item from Mrs. Tina Butcher (NIST OWM), Chair of the USNWG on Electric
19 Refueling & Submetering. See the Committee's 2018 Final Report for Details.

20 OWM personnel were unable to attend the 2019 NCWM Interim Meeting due to the Federal Government shutdown
21 in early 2019 due to a lack of appropriations; however, OWM provided written comments to the Committee on this
22 item in the advance of the meeting, including the following update on this item:

- 23 • The Electric Watthour Meter Subgroup (EWH SG) of the USNWG on Electric Vehicle Fueling & Submetering
24 has held multiple in-person and web meetings since the 2017 NCWM Annual Meeting.
- 25 • The SG met in September 2017, November 2017, May 2018, and August 2018. All meetings included web-
26 conferencing to allow those not able to attend in person to participate.
- 27 • The SG developed a proposed addition to NIST Handbook 130's Uniform Regulation for the Method of Sale
28 (MOS) of Commodities (see Item MOS-8 on the L&R Committee's Agenda) to specify a method of sale for
29 electrical energy sold through these systems and submitted the proposal to the four regional weights and measures
30 association meetings in Fall 2018.
 - 31 ○ Three of the four regions recommend the MOS proposal on the L&R Agenda as a voting item, with the
32 fourth abstaining due to lack of experience with these systems within the region.
- 33 • The SG continues work on a proposed code for EWH-type meters for NIST Handbook 44 and expects to have a
34 draft ready for the 2020 NCWM cycle.
- 35 • OWM requests this item be maintained on the S&T Committee's agenda as a Developing Item while the SG
36 finalizes its proposed HB 44 draft. OWM will continue to apprise the Committee of progress.

- 1 • At their Fall 2018 meetings, all four regional associations indicated support for maintaining this as a Developing
2 item on the Committee’s agenda.
- 3 • The SG will hold its next in-person meeting in February 2019 in Sacramento, CA. (*Technical Advisor’s Note:*
4 *This meeting was rescheduled to April 2019.*)
- 5 • Those interested in participating in this work please contact SG Chairman, Lisa Warfield, or Technical Advisor,
6 Tina Butcher. Contact information is included at the beginning of this item.

7 2019 NCWM Interim Meeting: The Committee heard no comments on this item. At its work session, Committee
8 members agreed with the submitter and the Regional Associations that this item should be assigned a Developing
9 status.

10 2019 NCWM Annual Meeting: Ms. Tina Butcher (NIST OWM) provided the Committee with an update on the further
11 development of this item. Ms. Butcher reported that the EWH SG will meet next in August 2019 to continue its work
12 and requested this item remain on the S&T Committee agenda as a Developing item. During the committee’s work
13 session, the Committee agreed with the submitter to retain this item in a Developing status.

14 2020 NCWM Interim Meeting: The Committee heard from Ms. Butcher who provided an update on developments in
15 the Electric Watthour Meters Code which is also included in the NIST OWM analysis. Ms. Butcher requested that
16 this item be given a developing status.

17 During the Committee work session, the committee agreed that this item should be given a Developing status.

18 2020 NCWM Annual Meeting: Due to the 2020 Covid-19 pandemic, this meeting was adjourned to January 2021, at
19 which time it was held as a virtual meeting. Due to constraint of time, only those items designated as 2020 Voting
20 Items were addressed. All other items were addressed in the subsequent 2021 NCWM Interim Meeting.

21 2021 NCWM Interim Meeting: The Committee heard from Ms. Tina Butcher who provided an update on the
22 developments in the Electric Watthour Code which is include in the NIST OWM analysis and Ms. Butcher requested
23 that this item be given a developing status.

24 During the Committee work session, the Committee agreed that the item be given a Developing status.

25 **Regional Association Comments:**

26 WWMA 2019 Annual Meeting: Ms. Lisa Warfield (NIST OWM) provided the Committee with an update on the
27 work group’s efforts. Mr. Clark Cooney (CA) encouraged the support from WWMA for this proposal and appreciates
28 the efforts of the work group developing the item. The Committee recommends that the submitter continue its efforts
29 on the development of this item.

30 SWMA 2019 Annual Meeting: The Committee heard no comments on this item The Committee decided to make
31 No Recommendation.

32 NEWMA 2019 Interim Meeting: The Committee and the body agree that this item should continue as a developing
33 item. No comments were heard during open hearings.

34 2020 Regional Meetings of the WWMA, NEWMA, and SWMA: These regions adhered to a condensed agenda due
35 to the Covid pandemic and did not consider this item.

36 CWMA 2020 Interim Meeting: The committee heard from numerous regulatory officials that this item is a good
37 addition to the handbook and recommended this item move forward as a voting item. We feel this item is fully
38 developed and recommend this item as a voting item.

39 Additional letters, presentation and data may have been submitted for consideration with this item. Please refer to
40 <https://www.ncwm.com/publication-16> to review these documents.

| CWMA Report |
|---|
| Comments and justification for the regional recommendation to NCWM: <i>(This will appear in NCWM reports)</i> |
| Tina Butcher (NIST OWM) reported that work was nearly complete on this item and that a draft version of the code should be ready for the next cycle of meetings. The CWMA S&T Committee recommends that this item remain Developing. |

1 **OTH-21.1 V Appendix A – 2.1. Acceptance and Maintenance Tolerances.**

2 **Source:**

3 Arizona Department of Agriculture, Weights and Measures Division

4 **Purpose:**

5 Provide consistency between the General Code and Appendix A for when acceptance tolerance applies.

6 **Item Under Consideration:**

7 Amend Handbook 44, Appendix A as follows:

8 **2.1. Acceptance and Maintenance Tolerances.** – The official tolerances prescribed by a weights and measures
9 jurisdiction for commercial equipment are the limits of inaccuracy officially permissible within that jurisdiction.
10 It is recognized that errorless value or performance of mechanical equipment is unattainable. Tolerances are
11 established, therefore, to fix the range of inaccuracy within which equipment will be officially approved for
12 commercial use. In the case of classes of equipment on which the magnitude of the errors of value or performance
13 may be expected to change as a result of use, two sets of tolerances are established: acceptance tolerances and
14 maintenance tolerances.

15 Acceptance tolerances are applied to new or newly reconditioned ~~or adjusted~~ equipment, **equipment returned**
16 **to service following official rejection, or equipment undergoing NTEP evaluation,** and are smaller than
17 (usually one-half of) the maintenance tolerances. Maintenance tolerances thus provide an additional range of
18 inaccuracy within which equipment will be approved on subsequent tests, permitting a limited amount of
19 deterioration before the equipment will be officially rejected for inaccuracy and before reconditioning or
20 adjustment will be required. In effect, there is assured a reasonable period of use for equipment after it is placed
21 in service before reconditioning will be officially required. The foregoing comments do not apply, of course,
22 when only a single set of tolerance values is established, as is the case with equipment such as glass milk bottles
23 and graduates, which maintain their original accuracy regardless of use, and measure-containers, which are used
24 only once.

25 **Previous Action:**

26 N/A

27 **Original Justification:**

28 Handbook 44 contains an inconsistency regarding the application of acceptance tolerance when evidence exists that a
29 commercial device has been adjusted during the past 30 days (for example maintenance documents or calibration
30 decals are applied demonstrating equipment adjustment). The General Code G-T.1. does not state that acceptance
31 tolerance would apply in this situation. However, Appendix A, Section 2.1 states “Acceptance tolerances are applied
32 to new or newly reconditioned or adjusted equipment and are smaller than (usually one-half of) the maintenance
33 tolerances” (underline added). The purpose of this proposed change is to update Appendix A to better reflect the
34 verbiage and intent of General Code G-T.1

35 In 2019, a proposal was submitted proposing a modification to General Code G-T.1. that would have applied
36 acceptance tolerance to equipment that has been adjusted as written in Appendix A (see item GEN-20.2). Based on
37 feedback provided at the regional level, it appears that commenters disagree that acceptance tolerance should be
38 applied following adjustment of equipment. Therefore, this proposal modifies Appendix A to remove language that

1 states acceptance tolerance shall be applied to “adjusted equipment” to reflect the requirements in General Code G-
2 T.1 and remove ambiguity.

3 The submitter requested voting status for this item in 2021.

4 **Comments in Favor:**

5 **Regulatory:**

- 6 • Supported and recommended Voting status.

7 **Industry:**

- 8 • Supported and recommended Voting status.

9 **Advisory:**

- 10 • The proposal eliminates conflicting statements between G-T.1. and Section 2.1. in Appendix A in HB
11 44. However, OWM believes there could be additional changes to General Code G-T.1. to provide
12 additional clarity as to when the application of acceptance tolerances are to be applied.

13 **Comments Against:**

14 **Regulatory:**

- 15 •

16 **Industry:**

- 17 •

18 **Advisory:**

- 19 •

20 **Neutral Comments:**

21 **Regulatory:**

- 22 •

23 **Industry:**

- 24 •

25 **Advisory:**

- 26 •

27 **Item Development:**

28 The Committee stated this item has merit and agreed with accepting the amendment as proposed by SMA. Those
29 changes recommended by the SMA are shown below as the added yellow highlighted text.

30 **Regional Associations’ Comments:**

31 WWMA 2020 Annual Meeting: Michelle Wilson (Arizona), submitter of the item, gave some background; in Arizona,
32 they’ve had debate on acceptance tolerance after calibration. Last year we submitted to clarify that acceptance
33 tolerance would be applied following adjustment. Majority felt that that was not appropriate. This is a form 15 to
34 clarify appendix A, section. 2.1. - currently says acceptance tolerance is applied to new or adjusted. This leaves it
35 open to interpretation. Removing "or adjusted" and add language to match the appendix with General code.
36 Recommend the item to move forward with Voting status. Mr. John Barton (NIST OWM) commented is not
37 convinced this is the only change needed to be made. For example, G.T.1. needs clarification when and when not to
38 apply. Mr. Brent Price (Gilbarco) agrees to remove “when adjusted”. He supports this item.

1 The Committee agrees the item is fully developed and recommends Voting status.

2 SWMA 2020 Annual Meeting: During Open Hearings the SWMA heard from Mr. Tim Chesser (Arkansas) who
3 stated that he supports the intent of the item but not the wording. Mr. Chesser suggested amending the code instead.
4 The SWMA also heard from Mr. John Barton (OWM) who stated that this is a revision of a previous proposal, and
5 that he agrees with the proposal. Mr. Barton also stated that enforcement of Acceptance Tolerance differs between
6 some jurisdictions in regard to routine adjustments. The SWMA also heard from Mr. Brent Price (Gilbarco) who
7 stated that he supports the proposal. He stated that many devices are adjusted routinely and shouldn't be considered
8 like new. Mr. Chesser also stated that the 30-day window for Acceptance Tolerance exists because a meter should
9 hold that adjustment for at least 30 days. If it cannot hold that calibration, it may be a bad meter. The SWMA also
10 heard from Mr. Ken Ramsburg (Maryland) who stated that he agrees with Mr. Chesser, and that this item would put
11 us at the mercy of the service agency to do a good job. The SWMA also heard from Mr. Hal Prince (Florida) who
12 stated he sees both sides, and doesn't want to dissuade good maintenance practices, but knows some service agencies
13 do poor work. After considering this item the SWMA S&T Committee recommends the item as a Voting Item.

14 NEWMA 2020 Interim Meeting: The NEWMA S&T Committee agrees with the body that this proposal has merit
15 and recommends that it be considered a Developing Item. During the open hearings, the NEWMA heard comments
16 that the submitter has been working on this item and removed a conflicting statement. There are still some questions
17 on routine maintenance and what precisely qualifies as an adjustment. There are also concerns that a device owner
18 who responsibly maintains their equipment may be held to higher tolerances than an individual that does not properly
19 maintain their equipment.

20 CWMA 2020 Interim Meeting: The CWMA heard from numerous regulatory officials that this item is a good addition
21 to the handbook and recommended this item move forward as a Voting item. We feel this item is fully developed and
22 recommend this item as a voting item.

23 Additional letters, presentation and data may have been submitted for consideration with this item. Please refer to
24 <https://www.ncwm.com/publication-16> to review these documents.

| CWMA Report |
|---|
| Comments and justification for the regional recommendation to NCWM: (This will appear in NCWM reports) |
| John Barton (NIST OWM) gave background and explanation as to the elimination of conflicts in NIST Handbook 44. While making changes into the Fundamental Considerations is appropriate, changes in the General Code to reflect these changes would also be beneficial. Russ Vires (SMA) supports this proposal with the following change: “Acceptance tolerances are applied to new or newly reconditioned or adjusted equipment, <u>equipment returned to service following official rejection for failure to conform to performance requirements, or equipment undergoing NTEP evaluation,</u> and...” The proposed SMA changes were agreed to by the NCWM S&T Committee during the January 2021 Interim meeting these changes were not reflected in the current proposal as presented. The CWMA S&T Committee recommends that this item proceeds as a voting item. |

-
- 25 Mr. Charles Stutesman, Kansas | Committee Chair
 - 26 Mr. Lenny Goebel, Illinois | Member
 - 27 Mr. Glen Raef, Missouri | Member
 - 28 Mr. Brett Willhite, Minnesota | Member
 - Ms. Nick Owens, Stark County, Ohio | NCWM Representative

Specifications and Tolerances Committee

Appendix A

Item SCL-20.12. – Summary of Revisions by the Submitter Following the 2020 Interim Meeting

| Section Number (from Pub 15) | Change | 2020 Publication 15 HB44 Revision Proposal | Current (21-July-2020) HB44 Revision Proposal |
|---------------------------------|---------------------|--|--|
| S.1.2.1 | Removed; not needed | <p>S.1.2.1. Digital Indicating Scales, Units.</p> <p><u>S.1.2.1.1. - Value of Other Units of Measure for Weigh-in-Motion Vehicle Scales.</u></p> <p><u>S.1.2.1.1.1. Speed. – Vehicle speeds shall be measured in miles per hour or kilometers per hour.</u></p> | -- |

| Section Number (from Pub 15) | Change | 2020 Publication 15 HB44 Revision Proposal | Current (21-July-2020) HB44 Revision Proposal |
|---------------------------------|---|--|---|
| S.1.8.6 | Section number changed to S.1.14; wording changed to remove some required values to be recorded | <p><u>S.1.8.6. Values to be Recorded, Weigh-In-Motion Vehicle Scales. – At a minimum, the following values shall be printed and/or stored electronically for each vehicle weighment:</u></p> <p><u>(e) lane identification (required if more than one lane at the site has the ability to weigh a vehicle in motion);</u></p> <p><u>(b) vehicle speed</u></p> <p><u>(c) vehicle direction</u></p> <p><u>(d) total vehicle weight;</u></p> <p><u>(e) time and date.</u></p> | <p><u>S.1.14 Weigh-In-Motion (WIM) Vehicle Scales - Values to be Recorded – At a minimum, the following values shall be printed and/or stored electronically for each vehicle weighment:</u></p> <p><u>(a) gross vehicle weight;</u></p> <p><u>(b) scale identification (required if more than one lane at the site has the ability to weigh a vehicle in motion); and</u></p> <p><u>(c) vehicle direction (required if the WIM vehicle scale is bi-directional).</u></p> |

| Section Number (from Pub 15) | Change | 2020 Publication 15 HB44 Revision Proposal | Current (21-July-2020) HB44 Revision Proposal |
|---------------------------------|--|---|---|
| S.1.14 | Section number changed to S.1.15; additional fault conditions identified; result of fault if fault condition is detected | <p><u>S.1.14. Weigh-in-Motion Vehicle Scales Operational Limitations.</u></p> <p><u>S.1.14.1. Identification of a Fault. – Fault conditions shall be presented to the operator in a clear and unambiguous means. The following fault conditions as well as others may be identified:</u></p> <p><u>(a) Vehicle speed is below the minimum or above the maximum speed as specified.</u></p> <p><u>(b) Direction of vehicle is not valid for this installation.</u></p> | <p><u>S.1.15. Weigh-in-Motion Vehicle Scales Operational Limitations.</u></p> <p><u>S.1.15.1. Identification of a Fault. – Fault conditions shall be presented to the operator in a clear and unambiguous means. No weight value shall be indicated or recorded when a fault condition is detected. The following fault conditions shall be identified if applicable:</u></p> <p><u>(a) Vehicle speed was below the minimum or above the maximum speed as specified.</u></p> <p><u>(b) Direction of vehicle was not valid for this installation.</u></p> <p><u>(c) A change in vehicle speed greater than that specified was detected.</u></p> <p><u>(d) The period of time all vehicle axles were simultaneously on the scale was below the minimum Data Acquisition Time.</u></p> <p><u>(e) Vehicle’s path of travel was outside the lateral side edges of the load-receiving element.</u></p> |
| S.2.1.2 | Removed; New definition for vehicle scale removes need for this change | <p>(b) 3.0 scale divisions for scales of more than 2000 kg (5000 lb) capacity in service prior to January 1, 1981, and for all axle load, railway track, <u>weigh-in-motion vehicle</u>, and vehicle scales; or</p> <p><u>(Amended 20XX)</u></p> | -- |

| Section Number (from Pub 15) | Change | 2020 Publication 15 HB44 Revision Proposal | Current (21-July-2020) HB44 Revision Proposal |
|---------------------------------|---|---|--|
| S.2.1.3 | Removed; New definition for vehicle scale removes need for this change | <p>S.2.1.3.1. Automatic Zero-Tracking Mechanism for Scales Manufactured Between January 1, 1981, and January 1, 2007. – The maximum load that can be “rezeroed,” when either placed on or removed from the platform all at once under normal operating conditions, shall be for:</p> <p>(c) bench, counter, and livestock scales: 0.6 scale division;</p> <p>(d) vehicle, <u>weigh-in-motion vehicle</u>, axle load, and railway track scales: 3.0 scale divisions; and (Amended 20XX)</p> <p>(d) all other scales: 1.0 scale division.</p> | -- |
| S.2.1.3.2 | Removed; New definition for vehicle scale removes need for this change | <p>S.2.1.3.2. Automatic Zero-Tracking Mechanism for Scales Manufactured on or after January 1, 2007. – The maximum load that can be “rezeroed,” when either placed on or removed from the platform all at once under normal operating conditions, shall be:</p> <p>(c) for vehicle, <u>weigh-in-motion vehicle</u>, axle load, and railway track scales: 3.0 scale divisions; and (Amended 20XX)</p> | -- |
| S.2.5.1 | Removed; New definition for vehicle scale removes need for this change | <p>26 S.2.5.1. Digital Indicating Elements. – <u>Except for weigh-in-motion vehicle scales, Digital digital</u> indicating elements equipped with recording elements shall be equipped with effective means to permit the recording of weight values only when the indication is stable within plus or minus: (Amended 20XX)</p> <p>(a) 3.0 scale divisions for scales of more than 2000 kg (5000 lb) capacity in service prior to January 1, 1981, hopper (other than grain hopper) scales with a capacity exceeding 22 000 kg (50 000 lb), and for all vehicle, <u>weigh-in-motion vehicle</u>, axle load, livestock, and railway track scales; and</p> <p>(b) 1.0 scale division for all other scales.</p> | -- |

| Section Number (from Pub 15) | Change | 2020 Publication 15 HB44 Revision Proposal | | | | | | Current (21-July-2020) HB44 Revision Proposal | | | | | |
|---------------------------------|--|--|--|----------|----------|--|--|--|--|--|----------|--|--|
| S.6 | Location of marking requirement changed; Wording of direction capability changed | <u>Minimum and Maximum Speed (25)</u> | | <u>X</u> | <u>X</u> | | | <u>Minimum and Maximum Speed (25)</u> | | | <u>X</u> | | |
| | | <u>Vehicle Direction Capability (26)</u> | | <u>X</u> | <u>X</u> | | | <u>Vehicle Direction Capability (26)</u> | | | <u>X</u> | | |
| | | <u>25. Weigh-in-Motion Vehicle Scales must be marked with minimum and maximum speed limitations.</u> (Added 20XX) | | | | | | <u>25. Weigh-in-Motion Vehicle Scales must be marked with minimum and maximum speed limitations.</u> (Added 20XX) | | | | | |
| | | <u>26. Weigh-in-Motion Vehicle Scales must be marked with direction capability (uni-directional, bidirectional).</u> (Added 20XX) | | | | | | <u>26. Weigh-in-Motion Vehicle Scales must be marked with direction restriction if uni-directional.</u> (Added 20XX) | | | | | |
| -- | N.7.1 Reference scale section added | -- | | | | | | <p><u>N.7.1. Reference Scale – a certified, static scale shall be used to establish all vehicle weights used in this procedure.</u></p> <p><u>N.7.1.1. The Reference Scale shall be of such dimension and spacing as to facilitate the single-draft static weighing of all Reference Vehicle weights.</u></p> <p><u>N.7.1.2. The Reference Scale should be located near the Weigh-in-Motion vehicle scale to minimize the effect of vehicle fuel consumption. The Reference Scale and the Weigh-in-Motion vehicle scale may be the same scale.</u></p> <p><u>N.7.1.3. The Reference Scale shall be verified immediately prior to using it to establish Reference Vehicle weights. To ensure the reliability of the reference scale’s performance when establishing the weight values for reference vehicles, a subsequent test of the reference scale may be performed immediately following the test of the WIM vehicle scale. To qualify for use as a suitable Reference Scale, it must meet NIST Handbook 44, Class III L acceptance tolerances. It shall also be capable of displaying in a higher resolution that permits loads to be weighed in 1/10 of the increment size of the WIM Scale.</u></p> | | | | | |

| Section Number (from Pub 15) | Change | 2020 Publication 15 HB44 Revision Proposal | Current (21-July-2020) HB44 Revision Proposal |
|---------------------------------|--|--|--|
| N.7.1 and N.7.2 | Test vehicle selection and test loads combined to N.7.2; major wording revisions | <p><u>N.7.1. Selection of Test Vehicles. – All testing associated with the procedures described in each of the subparagraphs of N.7.4. shall be performed with a minimum of two test vehicles.</u></p> <p><u>N.7.1.1. Test vehicles should be representative of the vehicles weighed on the scale typical to the system’s daily operation.</u></p> <p><u>N.7.2. Test Loads</u></p> <p><u>N.7.2.1. Reference vehicles. – Test vehicles used for dynamic testing (reference vehicles) shall be weighed empty and also weighed loaded to at least 85% of their legal maximum Gross Vehicle Weight. The “load” shall be non-shifting and shall be positioned to present as close as possible, an equal side to-side load.</u></p> <p><u>N.7.2.2. Test Loads. – All other test loads shall use certified test weights.</u></p> | <p><u>N.7.2. One or more Reference Vehicles shall be used to provide varying weight conditions for testing. Reference vehicles shall be representative of vehicles that are customarily weighed on the WIM vehicle scale during normal operation. Reference Vehicle length and axle spacing must comply with the minimum Data Acquisition Time allowed for the WIM vehicle scale.</u></p> <p><u>N.7.2.1. Loads shall be positioned to present as close as possible, an equal side-to-side load.</u></p> <p><u>N.7.2.2. Reference Vehicle(s) shall be selected to provide:</u></p> <p><u>a) A weight value above 2/3 the capacity of the Weigh-in-Motion vehicle scale,</u></p> <p><u>b) A weight value below 1/3 the capacity of the Weigh-in-Motion vehicle scale or the empty weight of a Reference Vehicle, and</u></p> <p><u>c) At least one weight value between the above weight values.</u></p> <p><u>N.7.2.3. Reference Vehicle(s) shall have their gross vehicle weight established on a Reference Scale as defined in N.7.1. immediately before being used to conduct the Weigh-in-Motion vehicle scale tests.</u></p> <p><u>N.7.2.3.1. If the weight of the Reference Vehicle changes during the test (e.g. due to fuel consumption, change of driver, etc.), a new, revised gross vehicle weight shall be established.</u></p> <p><u>N.7.2.4. Reference vehicles shall be weighed on a reference scale that provides the gross vehicle weight in a value that is 1/10 of an increment of the WIM scale.</u></p> |
| N.7.3 | Test speeds; major wording revision | <p><u>N.7.3. Test Speeds. – Dynamic tests shall be conducted at the minimum operating speed, maximum operating speed, and middle of the operating speed range that are specified for the Weigh-in-Motion vehicle scale.</u></p> | <p><u>N.7.3. Test speeds - a constant speed of the Reference Vehicle shall be maintained during each test (See also S.1.15.c).</u></p> <p><u>N.7.3.1 Various speeds of the Reference Vehicle shall be used between the minimum and maximum operating speed specified for the Weigh-in-Motion vehicle scale. The minimum speed capability of the Reference Vehicle may be used as the minimum speed.</u></p> |

| Section Number (from Pub 15) | Change | 2020 Publication 15 HB44 Revision Proposal | Current (21-July-2020) HB44 Revision Proposal | | |
|------------------------------|--|---|---|--|--|
| N.7.4 | Test procedures; major wording revision | <p><u>N.7.4 Dynamic Test Procedures</u></p> <p><u>N.7.4.1. Testing for a Weigh-in Motion-Vehicle Scale shall simulate the normal intended use as closely as possible i.e. test as used.</u></p> <p><u>N.7.4.2. The tests shall be conducted using the reference vehicles defined in N.7.1. Selection of Test Vehicles.</u></p> <p><u>N.7.4.3. The tests shall consist of a minimum of 10 runs for each test vehicle at the speeds as stated in N.7.3. Test Speeds.</u></p> <p><u>N.7.4.4. Tests should include empty and loaded vehicles, certified weights should be used for loaded vehicles.</u></p> <p><u>N.7.4.5. Direction Test. – Dynamic tests will be performed with reference vehicles in both directions, if applicable.</u></p> <p><u>N.7.4.6. Reference vehicles must stay within the defined roadway along the load receiving element. The tests shall be conducted with 6 runs with the vehicle centered along the width of the load receiving element; 2 runs with the vehicle on the right side along the width of the load receiving element; and 2 runs with the vehicle on the left side along the width of the load receiving element.</u></p> <p><u>N.7.4.7 At the conclusion of the dynamic tests there will be a minimum of 10 weight readings for each test vehicle. The tolerance for each weight reading shall be based on the Weigh-in-Motion Scale division and the acceptance tolerance values per Table 6. for Accuracy Class III L.</u></p> <p><u>(Added 20XX)</u></p> | <p><u>N.7.4. WIM Vehicle Scale Test Procedures - shall simulate the normal intended use as closely as possible (i.e. test as used).</u></p> <p><u>N.7.4.1. The WIM vehicle scale must comply with all applicable static vehicle scale tests as described in N.1. using certified weights.</u></p> <p><u>N.7.4.2. The tests shall be performed using the Reference Vehicle(s) defined in N.7.2.</u></p> <p><u>N.7.4.3. Each Reference Vehicle shall have a minimum of 10 weighments at the speeds as defined in N.7.3.</u></p> <p><u>N.7.4.4. Reference Vehicles must stay within the defined roadway along the load receiving element. (See also S.1.15.1.e).</u></p> <p><u>N.7.4.5. Direction Test. – The tests shall be performed in both directions, if applicable.</u></p> <p><u>N.7.4.6. At the conclusion of the WIM vehicle scale tests, there will be a minimum of 30 total weight readings for the Reference Vehicle(s) for each direction if applicable. The tolerance for each weight reading shall be based on the gross vehicle weights and the acceptance tolerance values per Table 6 for Accuracy Class III L.</u></p> <p><u>(Added 20XX)</u></p> | | |
| Table 7a | No Change | <table border="1" data-bbox="505 1650 976 1787"> <tr> <td data-bbox="505 1650 634 1787">III L</td> <td data-bbox="634 1650 976 1787">Vehicle scales (including weigh-in-motion vehicle scales), vehicle on-board weighing systems with a capacity greater than 30 000 lb, axle-load scales, livestock scales, railway track scales, crane scales, and hopper (other than grain hopper) scales</td> </tr> </table> | III L | Vehicle scales (including weigh-in-motion vehicle scales), vehicle on-board weighing systems with a capacity greater than 30 000 lb, axle-load scales, livestock scales, railway track scales, crane scales, and hopper (other than grain hopper) scales | |
| III L | Vehicle scales (including weigh-in-motion vehicle scales), vehicle on-board weighing systems with a capacity greater than 30 000 lb, axle-load scales, livestock scales, railway track scales, crane scales, and hopper (other than grain hopper) scales | | | | |

| Section Number (from Pub 15) | Change | 2020 Publication 15 HB44 Revision Proposal | Current (21-July-2020) HB44 Revision Proposal |
|---------------------------------|---|--|--|
| UR.2.5 | Removed; New definition for vehicle scale removes need for this change | UR.2.5. Access to Weighing Elements. – Adequate provision shall be made for ready access to the pit of a vehicle, <u>weigh-in-motion vehicle</u> , livestock, animal, axle-load, or railway track scale for the purpose of inspection and maintenance. Any of these scales without a pit shall be installed with adequate means for inspection and maintenance of the weighing elements. | -- |
| UR.2.6.1 | Removed; New definition for vehicle scale removes need for this change | UR.2.6.1. Vehicle Scales and Weigh-in-Motion Vehicle Scales. – On the entrance and exit end(s) of a vehicle scale <u>and weigh-in-motion vehicle scale</u> , there shall be a straight approach as follows: | -- |
| UR.3.2 | Removed; New definition for vehicle scale removes need for this change | UR.3.2.1. Maximum Loading for Vehicle Scales and Weigh-in-Motion Vehicle Scales. – A vehicle scale <u>and weigh-in-motion vehicle scale</u> shall not be used to weigh loads exceeding the maximum load capacity of its span as specified in Table UR.3.2.1. Span Maximum Load. (Added 1996) (Amended 20XX) | -- |
| UR.3.3 | Removed; New definition for vehicle scale removes need for this change | UR.3.3. Single-Draft Vehicle Weighing. A vehicle or a coupled-vehicle combination shall be commercially weighed on a vehicle scale <u>or a weigh-in-motion vehicle scale</u> only as a single draft. That is, the total weight of such a vehicle or combination shall not be determined by adding together the results obtained by separately and not simultaneously weighing each end of such vehicle or individual elements of such coupled combination. However, the weight of: | -- |
| UR.3.7 | Removed; New definition for vehicle scale removes need for this change | UR.3.7. Minimum Load on a Vehicle Scale or Weigh-in-Motion Vehicle Scale. – A vehicle scale <u>or weigh-in-motion vehicle scale</u> shall not be used to weigh net loads smaller than: | -- |

CWMA S&T 2021 Annual Meeting Report
 Appendix A – Item SCL-20.12. Summary of Revisions by the Submitter

| Section Number (from Pub 15) | Change | 2020 Publication 15 HB44 Revision Proposal | Current (21-July-2020) HB44 Revision Proposal |
|------------------------------|---|--|---|
| UR.3.9 | Removed; New definition for vehicle scale removes need for this change | (e) livestock, and vehicle scales, <u>and weigh-in-motion vehicle scales</u> generate weight tickets to correct erroneous tickets. | -- |
| Appendix D | Wording change for vehicle scale; reference vehicle and WIM vehicle scale added | <p>vehicle scale. – A scale adapted to weighing highway, farm, or other large industrial vehicles (except railroad freight cars), loaded or unloaded. [2.20]</p> <p>...</p> <p>weigh-in-motion vehicle scale. – A scale adapted to weighing highway, farm, or other large industrial vehicles (except railroad freight cars), loaded or unloaded, <u>in a single draft while these vehicles move continuously across the scale.</u> [2.20] <u>(Amended and 20XX)</u></p> | <p><u>reference vehicle.</u> – <u>A test vehicle with an associated load, including the driver, that has been statically weighed for temporary use as a mass standard for a short period of time, typically the time required to test one Weigh-in-Motion vehicle scale.</u> [2.20] <u>(Added 20XX)</u></p> <p>...</p> <p>vehicle scale. – A scale <u>(including weigh-in-motion vehicle scales)</u> adapted to weighing highway, farm, or other large industrial vehicles (except railroad freight cars), loaded or unloaded. [2.20] <u>(Added 20XX)</u></p> <p>...</p> <p><u>weigh-in-motion (WIM) vehicle scale.</u> – <u>A vehicle scale adapted to weighing highway, farm, or other large industrial vehicles (except railroad freight cars), loaded or unloaded, in a single draft while these vehicles travel across the scale.</u> [2.20] <u>(Added 20XX)</u></p> |

Appendix B

Item Block 2 – Final Report of the Verification Scale Division Task Group

Participants:

Doug Musick, Chair (KS)
Ross Andersen (NY, Retired and original submitter of the item)
John Barton (NIST OWM)
Luciano Burtini (Measurement Canada)
Anthony Bong Lee (Orange County, CA)
Steve Cook (CA, Retired)
Darrell Flocken (NTEP)
Eric Golden (Cardinal Scale)
Jan Konijnenburg (Rice Lake Weighing Systems)
Richard Suiter (Richard Suiter Consulting)
Steve Timar (NY)
Howard Tucker (FL)

The mission of the task group, as defined by the S&T Committee, is to review Handbook 44, Section 2.20. Scales and relevant portions of OIML R76, using the items included in S&T Agenda Items: Block 2 as a reference point, and recommend changes as necessary to:

1. Clarify how the error is determined in relation to the verification scale division (e) and the scale division (d)
2. Clarify which is the proper reference; the verification scale division (e) or the scale division (d) throughout this section
3. Ensure proper selection of a scale in reference to the verification scale division (e) and the scale division (d)
4. Clarify the relationship between the verification scale division (e) or the scale division (d)

This report is divided into three sections:

1. Clarify the relationship between e and d, i.e. ensure we understand the terms. (Mission items 4 and 1)
2. Propose changes to the Scales Code, if necessary, to ensure the code correctly identifies e or d as appropriate to the code paragraph. (Mission items 2 and 3)
3. Address other issues that arose as potential problems that might require additional investigation beyond the scope of this workgroup.

PART 1. Clarify the Relationship Between e and d.

We begin by looking at current HB44 definitions. The verification scale division e is used to express tolerance values and it is used in classification. The designations of e and the accuracy class are made by the manufacturer. The scale division d is a function of the actual scale function and display. Note that for weight classifiers, the weighing instrument may never display quantity at the resolution of e, and for ungraduated devices there is no scale division d to permit comparison to e.

verification scale division, value of (e). – A value, expressed in units of weight (mass) and specified by the manufacturer of a device, by which the tolerance values and the accuracy class applicable to the device are determined. The verification scale division is applied to all scales, in particular to ungraduated devices since they have no graduations. The verification scale division (e) may be different from the displayed scale division (d) for certain other devices used for weight classifying or weighing in pre-determined amounts, and certain other Class I and II scales.[2.20]

scale division, value of (d). – The value of the scale division, expressed in units of mass, is the smallest subdivision of the scale for analog indication or the difference between two consecutively indicated or printed values for digital indication or printing. (Also see “verification scale division.”) [2.20, 2.22]

scale division, number of (n). – Quotient of the capacity divided by the value of the verification scale division. [2.20]

$$n = \frac{\text{Capacity}}{e}$$

The values of e and d must be understood as referring to different things. The verification scale refers to the scale of measurement for the reference (or true value), think of the reference standard. The instrument scale refers to the scale of measurement of the instrument under test. Consider this assortment of instruments in the table below. It should be clear that the divisions of the verification scale do not always equal those on the instrument scale and may not even be in the same units. In addition, when we employ an artifact, like a test weight or slicker plate measure, the divisions of the verification scale are not visible since the artifact represents a single point on the measurement scale of the reference.

| Instrument Scale | Scale div d | Verification “True Value” Scale | Scale div e | Relation e to d |
|------------------|-------------|---------------------------------|-------------|---------------------|
| Rule | 1/16 in | Standard Rule or Tape | 1/16 in | e = d |
| Taximeter | 1/10 mi | Road Course | 2 ft | e << d |
| LMD’s | 0.1 gal | Prover indication | 5 cu in | e > d |
| Mass Flow Meter | 1 lb | Reference Scale | 0.01 lb | e < d |
| Weighing Devices | 0.01 lb | Test Weight (artifact) | mfr choice | e < d, e = d, e > d |
| Test Measure | 1 cu in | Slicker Plate (artifact) | ? | e ? d |

For weighing instruments, it turns out that e and d have no fixed relationship. It is different for weight classifiers (e < d), for most instruments (e = d), and for high resolution instruments (e>d). The critical point is that the instrument scale and the verification scale are independent of each other. Once you have disconnected e (declared by the manufacturer) from d (displayed on the instrument), it may now become evident that much of our confusion arose because we thought of them as connected in some way.

In the graphics below both error and tolerance are always expressed in terms of the divisions (e) of the verification scale. The primary assumption is that the verification scale is constant, and it is the displayed scales of the instruments we test that move. The scales in black are depicted as in error by +1 e or -1 e.

Error of delivery =
 verification scale – instrument scale
 + in excess
 – in deficiency

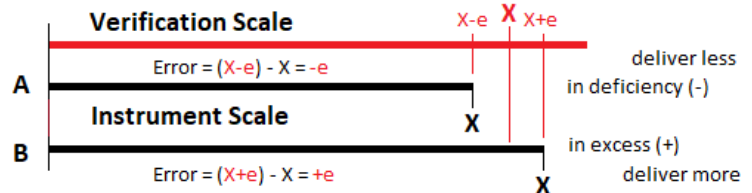

Error of Indication =
 instrument scale – verification scale
 + overregistration
 – underregistration

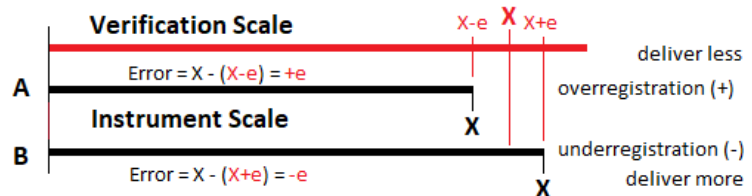

Much of our confusion arises because scales are tested using artifacts with no visible scale divisions. We could mirror this in the test of a fuel dispenser. Normally you stop the test at 5 gallons on the instrument scale and read the error as - 3 cu in from the test measure (verification) scale. Now change that procedure and stop the test at the zero mark on the test measure. How would you determine the error? Assume the instrument now reads 5.012 gal. The error is -0.012 gal (-3 cu in), and we calculate it as verification scale – instrument scale. We determined the error from the instrument scale. The verification scale division, however, did not switch from the test measure to the instrument simply because we changed the procedure. The verification scale division remains 1 cu in and is still on the test measure, the reference.

Consider the Class III scale at right where $e = d$. Technically you can't see divisions on either scale since the artifact has no visible divisions and the instrument is digital. The correct instrument indication of 500 d is 1.2 e short of 500 e on the verification scale. You could mirror this by applying 498.8 e of test weights to get indication of 500 d. It is not in tolerance, but only if you apply error weights in your test.

Consider the Class II scale at right where $e = 10 d$. You can't see divisions on either scale because the test weight is an artifact and the instrument are digital. The correct instrument indication of 50,000 d is short of the 5,000 e on the verification scale by 7 d. Thus, we say the error is +0.7 e. Error = instrument scale – verification scale. This instrument is clearly in tolerance. No error weights are necessary to see to finer than 1 e.

The principles of classification are found in the following HB44 paragraphs. In principle, the manufacturer tells the official what accuracy is to be applied to the instrument.

T.N.1. Principles.

T.N.1.1. Design. – The tolerance for a weighing device is a performance requirement independent of the design principle used.

T.N.1.2. Accuracy Classes. – Weighing devices are divided into accuracy classes according to the number of scale divisions (n) and the value of the scale division (d). **Error! Bookmark not defined.**

T.N.1.3. Scale Division. – The tolerance for a weighing device is related to the value of the scale division (d) or the value of the verification scale division (e) and is generally expressed in terms of d or e.

Yet, the T.N.1.2. and T.N.1.3. paragraphs conflict with the definitions. According to the definition of e, it is e “by which the tolerance values and the accuracy class applicable to the device are determined.” When the Scales Code was drafted prior to adoption in 1984, it appears some things were lost in translation from the OIML R76 on which it was based. What was lost can be expressed as those things not included in HB44 and those things incorrectly translated in HB44.

For example, R76 expresses the classification information in four required markings, and one auxiliary marking. R76 requires marking of Class, Max, e, and Min, and requires marking of d if different from e. Those markings describe the maximum and minimum loads and the relative accuracy. In contrast, HB44 requires marking of Class, capacity, and d, and requires marking of e if different from d. HB44 does not require marking of minimum load. While R76 considers minimum load part of the class structure, HB44 does not.

It is this switch of e and d that causes confusion because the translation of R76 to HB44 lost some of the meaning. Much of the second part of this report covers the changes required to rectify the situation. The workgroup is attempting to ensure the Code states e when the requirement applies to e and d when it applies to d. The workgroup is also proposing to add important material from R76 that is missing.

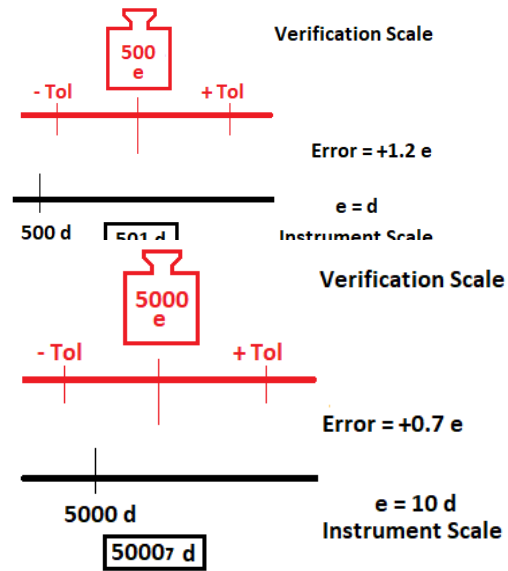

Some additional confusion comes from the stepped tolerance structure. For example, it is common to think that the instrument gets 1 division of error over the first tolerance step (maintenance). The correct interpretation of the code requires the instrument maintain a % accuracy based on the number of divisions of load at the break points. The space under the step riser is not supposed to be used by the instrument provided you eliminate the rounding error.

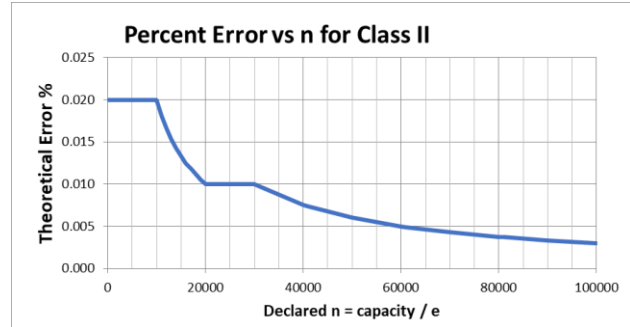

Between 1 division and 10,000 divisions for Class II in R76, this is 0.02%. At 10,000 e, 0.02% is 2 e. At 1,000 e, 0.02% is 0.2 e, and at minimum load of 50 e, 0.02% is 0.01 e. The principle is: the larger the number of verification scale divisions (n) the more accurate the instrument must be, i.e. relative error. Section 2.2 of R76 makes this clear by stating that e represents absolute accuracy and n represents relative accuracy. The Scales Code has no parallel section. It is the relative accuracy that should be our focus, but that's not found in HB44.

PART 2. Proposed changes to the Scales Code (related issues are grouped for convenience)

Group 1. Changes to clarify definitions relating to e.

verification scale division, value of (e). – A value, expressed in units of weight (mass) and specified by the manufacturer of a device, by which the tolerance values and the accuracy class applicable to the device are determined. The verification scale division is applied to all scales, in particular to ungraduated devices since they have no graduations. ~~The verification scale division (e) may be different from the displayed scale division (d) for certain other devices used for weight classifying or weighing in pre determined amounts, and certain other Class I and II scales.~~[2.20]

(Amended 20XX)

The last sentence is explained fully in the technical requirements in the Code. The workgroup finds it unnecessary and believe it contributes to confusion.

verification scale division, number of (n). – Quotient of the capacity divided by the value of the verification scale division. [2.20]

$$n = \frac{Capacity}{e}$$

(Amended 20XX)

scale division, number of (n). – See “verification scale division, number of (n)”

The addition of the word “verification” to the definition of n is essential since without it the section refers to the scale division d. The second definition for n was added as a cross reference since the revision will move from the s section to the v section.

Group 2. Changes to ensure proper classification of instruments.

T.N.1.2. Accuracy Classes. – Weighing devices are divided into accuracy classes according to the number of verification scale divisions (n) and the value of the verification scale division ~~(d)~~ (e).

(Amended 20XX)

T.N.1.3. Verification Scale Division. – The tolerance for a weighing device is ~~related to the value of the scale division (d) or the value of the~~ in the order of magnitude of the verification scale division (e) and is generally expressed in terms of ~~d or e~~.

(Amended 20XX)

These changes bring the principles in the T.N. section in agreement with the definitions. Classification is exclusively based on e.

| Table 3. <i>Parameters for Accuracy Classes</i> | | | |
|---|---|---|----------------|
| <i>Class</i> | <i>Value of the Verification Scale Division (d or e¹)</i> | <i>Number of Verification Scale⁴ Divisions (n)</i> | |
| | | <i>Minimum</i> | <i>Maximum</i> |
| <i>SI Units</i> | | | |
| <i>I</i> | <i>equal to or greater than 1 mg</i> | <i>50 000</i> | <i>--</i> |
| <i>II</i> | <i>1 to 50 mg, inclusive</i> | <i>100</i> | <i>100 000</i> |
| | <i>equal to or greater than 100 mg</i> | <i>5 000</i> | <i>100 000</i> |
| <i>III^{2,5}</i> | <i>0.1 to 2 g, inclusive</i> | <i>100</i> | <i>10 000</i> |
| | <i>equal to or greater than 5 g</i> | <i>500</i> | <i>10 000</i> |
| <i>III L³</i> | <i>equal to or greater than 2 kg</i> | <i>2 000</i> | <i>10 000</i> |
| <i>IIII</i> | <i>equal to or greater than 5 g</i> | <i>100</i> | <i>1 200</i> |

The middle section of the table was not included for brevity. Notes continue below:

¹ *For Class I and II devices equipped with auxiliary reading means (i.e., a rider, a vernier, or a least significant decimal differentiated by size, shape, or color), the value of the verification scale division “e” is the value of the scale division immediately preceding the auxiliary means. The verification scale division e does not always equal the displayed scale division d. To ensure the correct value for e is used, refer to required markings on the device (see also notes 3 and 4 in Table S.6.3.b.).*

² *A Class III scale marked “For prescription weighing only” may have a verification scale division (e) not less than 0.01 g.*

(Added 1986) (Amended 2003)

³ *The value of a verification scale division for crane and hopper (other than grain hopper) scales shall be not less than 0.2 kg (0.5 lb). The minimum number of verification scale divisions, n, shall be not less than 1000.*

⁴ *On a multiple range or multi-interval scale, the number of verification divisions, n, for each range independently shall not exceed the maximum specified for the accuracy class. The number of verification scale divisions, n, for each weighing range is determined by dividing the scale capacity for each range by the verification scale division, e, for each range. On a scale system with multiple load-receiving elements and multiple indications, each element considered shall not independently exceed the maximum specified for the accuracy class. If the system has a summing indicator, the n_{max} for the summed indication shall not exceed the maximum specified for the accuracy class.*

(Added 1997)

⁵ *The minimum number of verification scale divisions, n, for a Class III Hopper Scale used for weighing grain shall be 2000.)*

[Nonretroactive as of January 1, 1986]

(Amended 1986, 1987, 1997, 1998, 1999, 2003, ~~and~~ 2004 and 20XX)

The changes to the header of Table 3 ensure the classification is based on e consistent with the definitions and the principles in T.N.1. The scale division d is not involved in classification. This change should reduce confusion. The changes to the notes at the bottom of the table again ensure e is correctly referenced instead of d or the “scale division.” Referencing “n” in notes 3, 4, and 5 ensure that it is referring to e since $n = \text{capacity} / e$.

| Table S.6.3.a. Marking Requirements | | | | | |
|---|---|---|---|-------------------------------|---------------------------------------|
| To Be Marked With ↓ | Weighing Equipment | | | | |
| | Weighing, Load-Receiving, and Indicating Element in Same Housing or Covered on the Same CC¹ | Indicating Element not Permanently Attached to Weighing and Load-Receiving Element or Covered by a Separate CC | Weighing and Load-Receiving Element Not Permanently Attached to Indicating Element or Covered by a Separate CC | Load Cell with CC (11) | Other Equipment or Device (10) |
| Manufacturer’s ID (1) | X | X | X | X | X |
| Model Designation and Prefix (1) | X | X | X | X | X |
| Serial Number and Prefix (2) | X | X | X | X | X (16) |
| Certificate of Conformance Number (CC) (23) | X | X | X | X | X (23) |
| Accuracy Class (17) | X | X (8) | X (19) | X | |
| Nominal Capacity (3)(18)(20) | X | X | X | | |
| Value of Scale Division, “d” (3 4) | X | X | | | |
| Value of <u>Verification Scale Division</u> , “e” (4 3) | X | X | | | |
| Temperature Limits (5) | X | X | X | X | |

Note: The remainder of the table was not included for brevity.

The changes to column 1 in the 7th and 8th rows simply reverse the references to the notes in Table S.6.3.b. They reflect the primacy of e in classification, which is addressed in parallel changes to notes 3 and 4 in Table S.6.3.b. (see changes to Table S.6.3.b. below).

Table S.6.3.b.
Notes for Table S.6.3.a. Marking Requirements

1. Manufacturer's identification and model designation and *model designation prefix*.*
[*Nonretroactive as of January 1, 2003]
(Also see G-S.1. Identification.) [*Prefix lettering may be initial capitals, all capitals or all lower case*]
(Amended 2000)
2. *Serial number* [Nonretroactive as of January 1, 1968] and *prefix* [Nonretroactive as of January 1, 1986]. (Also see G-S.1. Identification.)
3. The device shall be marked with the nominal capacity. *The nominal capacity shall be shown together with the value of the verification scale division, "e" (e.g., 15 × 0.005 kg, 30 × 0.01 lb, or capacity = 15 kg, ~~d~~ e = 0.005 kg) in a clear and conspicuous manner and be readily apparent when viewing the reading face of the scale indicator unless already apparent by the design of the device. Each verification scale division value ~~or weight unit~~ with its associated nominal capacity shall be marked on multiple range or multi-interval scales. In the absence of a separate marking of the scale division "d" (see Note 4), the value of the scale division "d" shall be equal to the value of the verification scale division "e."*
[Nonretroactive as of January 1, 1983]
(Amended 2005 and 20XX)
4. *Required only if different from "d": "e." This does not apply to an ungraduated device (equal arm scale) where the graduations do not refer to a fixed weight value.*
[Nonretroactive as of January 1, 1986]
(Amended 20XX)

The original Scales Code adopted 1984 made d the primary mandatory marking but this resulted in confusion. The changes make e the mandatory marking and now requires d only if different from e.

The changes regarding multiple range and multi-interval scales makes the note say what we have always been applying. The intent was for each range or subrange of the instrument to have marking of capacity and e. The "or weight unit" could refer to lb or kg, but that is clearly not the intent.

There is some concern if this might pose problems for existing equipment. If the marking is of the form "capacity 30 lb x 0.01 lb" the workgroup sees not conflict. However, markings in the form "capacity = 30 lb d = 0.01 lb" would cause a conflict as devices using that form would no longer conform with the proposed changes. The workgroup decided to refer this to the scale manufacturers to see if there are any devices in the marketplace that would be affected. We also learned that this might cause a conflict with Measurement Canada as they do see devices with markings of capacity= d=. Note this is not an issue when $e \neq d$ as both markings are already required by the combination of notes 3 and 4. If necessary, a note with qualification "devices manufactured before January 1, 20XX" could be added to accept existing scales marked with d = provided d = e.

S.1.2.2. Verification Scale ~~Interval~~ Division

The magnitude of the verification scale division *e* relative to the scale division *d* for different types of devices is given in Table S.1.2.2. Relative Magnitude of *e* to *d*.

| Table S.1.2.2. Relative Magnitude of <i>e</i> to <i>d</i> | |
|--|--|
| Type of device (see Note) | Relative magnitude of <i>e</i> to <i>d</i> |
| <u>Graduated, without an auxiliary indicating device</u> | <u>$e = d$</u> |
| <u>Graduated, with an auxiliary indicating device</u> | <u>$e > d$ and <i>e</i> is chosen by the manufacturer according to Table 3. and S.1.2.2.1.</u> |
| <u>Graduated, and marked for use in special applications (weight classifier)</u> | <u>$e < d$ and <i>e</i> is chosen by the manufacturer according to Table 3. and S.1.2.2.4.</u> |

*Note: Ungraduated devices, e.g. equal arm balances where the scale graduations do not represent a fixed weight quantity, are not included in this table since they have no scale divisions (*d*) to permit comparison with (*e*).*

S.1.2.2.1. Class I and II Scales and Dynamic Monorail Scales. – If $e \neq d$, the verification scale ~~interval~~ division “*e*” shall be determined by the expression:

$$d < e \leq 10 d$$

If the displayed scale division (*d*) is less than the verification scale division (*e*), then the verification scale division shall be less than or equal to 10 times the displayed scale division.

The value of *e* must satisfy the relationship, $e = 10^k$ of the unit of measure, where *k* is a positive or negative whole number or zero. This requirement does not apply to a Class I device with $d < 1$ mg where $e = 1$ mg. If $e \neq d$, the value of “*d*” shall be a decimal submultiple of “*e*,” and the ratio shall not be more than 10:1. If $e \neq d$, and both “*e*” and “*d*” are continuously displayed during normal operation, then “*d*” shall be differentiated from “*e*” by size, shape, color, etc. throughout the range of weights displayed as “*d*.”

(Added 1999) (~~Amended 20XX~~)

S.1.2.2.2. Class I and II Scales Used in Direct Sales. – *When accuracy Class I and II scales are used in direct sale applications the value of the displayed division “*d*” shall be equal to the value of the verification scale interval “*e*.”*

[Nonretroactive as of January 1, 2020; to become retroactive as of January 1, 2023]

(Added 2017)

S.1.2.2.3. Deactivation of a “*d*” Resolution. – It shall not be possible to deactivate the “*d*” resolution on a Class I or II scale equipped with a value of “*d*” that differs from “*e*” if such action affects the scale’s ability to round digital values to the nearest minimum unit that can be indicated or recorded as required by paragraph G-S.5.2.2. Digital Indication and Representation.

(Added 2018)

S.1.2.2.4. Class III and IIII Scales. The value of “e” is specified by the manufacturer as marked on the device. Except for dynamic monorail scales, “e” must be less than or equal to “d.”
(Added 1999)

~~S.5.3. S.1.2.2.5.~~ **Multi-Interval and Multiple Range Scales, Division Value.** – On a multi-interval scale ~~and~~ or a multiple range scale, the value of “e” shall be equal to the value of “d.”
(Added 1986) (Amended 1995 and 20XX)

S.1.2.2.6. Class IIII Scales. On Class IIII scales the value of “e” shall equal the value of “d.”
(Added 20XX)

(Add new definition)

auxiliary indicating device. – a means to increase the display resolution of a weighing device, such as a rider or vernier on an analog device, or a differentiated least significant digit to the right of the decimal point on a digital device. [2.20]

(Added 20XX)

Section S.1.2.2. is a key part of understanding application of e and d. The first change was to make references uniform to verification scale “division” as used in all other parts of the code. This section currently uses the term verification scale “interval”. Several additions of the term “scale” were also added to S.1.2.2.1. for clarity. Of note, R76 exempts Class I from the e not greater than 10 d requirement when e = 1 mg or less.

A major addition is the new text and table in T.1.2.2. This would create a parallel section in HB44 to R76 section 3.1.2 and Table 2. This section describes four types of instruments:

1. Graduated without an auxiliary indicating device – most instruments e = d
2. Graduated with an auxiliary indicating device – Class I and II with high resolution e > d
3. Graduated & marked for special applications – weight classifiers (round down instruments) e < d
4. Ungraduated – equal arm balances where graduations don’t refer to fixed weight quantities. No d

These four types also impact application of minimum load in Table 8.

The current S.5.3. was moved to this section as S.1.2.2.5. to keep these paragraphs dealing with the magnitude of e and d together. A new paragraph S.1.2.2.6. was added to address Class IIII where e should always equal d. Now all classes (I, II, III, IIII, and IIII) are covered in S.1.2.2. to clarify relative magnitude of e and d.

The addition of the definition rounds out the expansion of this section

~~S.5.4. S.5.3.~~ **Relationship of Minimum Load Cell Verification Interval Value to the Verification Scale Division.** – The relationship of the value for the minimum load cell verification scale interval, v_{min} , to the verification scale division, d e, for a specific scale using National Type Evaluation Program (NTEP) certified load cells shall comply with the following formulae where N is the number of load cells in a single independent¹ weighing/load-receiving element (such as hopper, railroad track, or vehicle scale weighing/load-receiving elements):

(a) $v_{min} \leq \frac{d^* e}{\sqrt{N}}$ for scales without lever systems; and

(b) $v_{min} \leq \frac{d^* e}{\sqrt{N} x \text{ (scale multiple)}}$ for scales with lever systems.

[*When the value of the scale division, d, is different from the verification scale division, e, for the scale, the value of e must be used in the formulae above.]

This requirement does not apply to complete weighing/load-receiving elements or scales, which satisfy all the following criteria:

- *the complete weighing/load-receiving element or scale has been evaluated for compliance with T.N.8.1. Temperature under the NTEP;*
- *the complete weighing/load-receiving element or scale has received an NTEP Certificate of Conformance; and*
- *the complete weighing/load-receiving element or scale is equipped with an automatic zero-tracking mechanism which cannot be made inoperative in the normal weighing mode. (A test mode which permits the disabling of the automatic zero-tracking mechanism is permissible, provided the scale cannot function normally while in this mode.*

[Nonretroactive as of January 1, 1994]

(Added 1993) (Amended 1996, ~~and~~ 2016, and 20XX)

The renumbering resulted from the move of S.5.3. to the S.1.2.2. section as S.1.2.2.5. The other changes correctly reference e instead of d in this section. Technically, v_{min} for load cells corresponds to verification scale division e for weighing instruments. They are accuracy ratings declared by the manufacturer. There is no significant change for the inspector in properly referring to e since for scales where $e = d$ the issue is moot and when $e \neq d$ the section already directed the use of e. With the change the inspector will always use e.

Group 3. Changes to clarify appropriate application of tolerances (Marked Scales)

| Table 6. | | | | |
|---|------------------|------------------|---|----------|
| Maintenance Tolerances | | | | |
| (All values in this table are in <u>verification</u> scale divisions “e”) | | | | |
| Tolerance in Scale Divisions | | | | |
| | 1 | 2 | 3 | 5 |
| Class | Test Load | | | |
| I | 0 - 50 000 | 50 001 - 200 000 | 200 001 + | |
| II | 0 - 5 000 | 5 001 - 20 000 | 20 001 + | |
| III | 0 - 500 | 501 - 2 000 | 2 001 - 4 000 | 4 001 + |
| IIII | 0 - 50 | 51 - 200 | 201 - 400 | 401 + |
| III L | 0 - 500 | 501 - 1 000 | (Add 1 e for each additional 500 e or fraction thereof) | |

The proper reference in this section has always been e, and this is how it has always been interpreted. The current language says “scale divisions” which technically refers to d. This means we weren’t following the Code. The removal of “in Scale Divisions” after Tolerances in the second row was made to provide parallel construction with the header for Test Load. The parenthetical at the top should be sufficient to cover both sections of the table.

The change for Class III L was made since e should be used to specify tolerances and we added S.1.2.2.6. requiring that $d = e$ for this class.

T.N.3.4. Crane and Hopper (Other than Grain Hopper) Scales. – The maintenance and acceptance tolerances shall be as specified in T.N.3.1. Maintenance Tolerance Values and T.N.3.2. Acceptance Tolerance Values for Class III L, except that the tolerance for crane and construction materials hopper scales shall not be less than 1 ~~e~~ or 0.1 % of the scale capacity, whichever is less.

(Amended 1986 ~~and~~ 20XX)

T.N.4.3. Single Indicating Element/Multiple Indications. – In the case of an analog indicating element equipped with two or more indicating means within the same element, the difference in the weight indications for any load other than zero shall not be greater than one-half the value of the verification scale division (e) (~~d~~) and be within tolerance limits.

(Amended 1986)

The reference to tolerances in T.N.3.4. and T.N.4.3. should follow the principle of expressing tolerances in e.

Group 4. Changes to clarify appropriate application of tolerances (Unmarked Scales)

T.1. General. – The tolerances applicable to devices not marked with an accuracy class shall have the tolerances applied as specified in Table T.1.1. Tolerances for Unmarked Scales.

Note: When Table T.1.1. refers to T.N. sections it shall be accepted that the scale division d on the unmarked scale always equals the verification scale division e.

(Amended 20XX)

Prior to 1984, tolerances were based on percentage of load for most scales. There was no concept of verification scale division e. In the T.N. section all tolerances are expressed in e. The note is added to clarify that d for the T. section is always equal to e from the T.N. section.

The workgroup noted that several specific paragraphs in the T. section for unmarked scales refer to tolerances in terms of d. Those sections are shown below. With the addition of the note to T.1. General, it was decided that it was not appropriate or necessary to change the d to e in these paragraphs.

T.2.2. General. – Except for scales specified in paragraphs T.2.3. Prescription Scales through T.2.8. Railway Track Scales: 2 d, 0.2 % of the scale capacity, or 40 lb, whichever is least.

T.2.4.2. With More Than One-Half Ounce Capacity. – 1 d or 0.05 % of the scale capacity, whichever is less.

T.2.7. Vehicle, Axle-Load, Livestock, and Animal Scales.

T.2.7.1. Equipped With Balance Indicators. – 1 d.

T.2.7.2. Not Equipped With Balance Indicators. – 2 d or 0.2 % of the scale capacity, whichever is less.

T.2.8. Railway Track Scales. – 3 d or 100 lb, whichever is less.

Group 5. Changes to clarify appropriate scale selection (reference Table 8)

| Table 8. | | |
|---------------------------------|---|--|
| Recommended Minimum Load | | |
| Class | Value of <u>Verification</u> Scale Division “e” (d or e*) | Recommended Minimum Load <u>in</u> scale divisions “d” (See notes) (d or e*) |
| I | equal to or greater than 0.001 g | 100 |
| II | 0.001 g to 0.05 g, inclusive equal to or greater than 0.1 g | 20 50 |
| III | All** | 20 |
| III L | All | 50 |
| IIIH | All | 10 |

*For Class I and II devices equipped with auxiliary reading means (i.e., a rider, a vernier, or a least significant decimal differentiated by size, shape or color), the value of the verification scale division “e” is the value of the scale division immediately preceding the auxiliary means. For Class III and IIIH devices

the value of “e” is specified by the manufacturer as marked on the device; “e” must be less than or equal to “d.”

The displayed scale division d is not always equal to the verification scale division e. To ensure the correct values are used, refer to required markings on the device (see also notes 3 and 4 in Table S.6.3.b.).

For an ungraduated device, the scale division d shall be replaced with the verification scale division e in the last column.

******A minimum load of ~~10 d~~ 5 e is recommended for a weight classifier marked in accordance with a statement identifying its use for special applications.

In the header, the change in column 2 references e and the change in column 3 references d and directs you to the notes. Currently, the Code references (d or e) in both columns which causes confusion. We’re never sure which one to use. The justification for d in the last column follows below.

It is vital to understand that Table 8. is tied closely to Table 3. You will find that header to the first two columns in both tables, with these changes, will be identical. The workgroup also revised the * note to remove the * and use parallel text to revised note 1 of Table 3. The notes section contains two special exceptions to the general values in column 3 the table. The first directs you to use e in the last column for ungraduated instruments, as these have no d values. The second directs you to use a minimum load of 5 e for weight classifiers. This aligns the value with R76. Note that the use of d for weight classifiers leads to unusual situations. Two weight classifiers with 100 lb capacity and e of 0.05 lb should have the same minimum load. However, they might have very different d values, say 1 lb and 0.2 lb. Declaring minimum load as 10 d for these result in very large differences of 10 lb minimum load for the first instrument and 2 lb for the second. Since $e < d$ for weight classifiers, the minimum load is correctly expressed in e.

Understanding Minimum Load

In R76, minimum load “Min” is included in the principles of classification, see 2.2. below. There are 4 mandatory markings; Class, Max, Min and e. When R76 was translated into HB44 a conscious decision was made to remove Min from the classification and make it a user requirement. Thus, HB44 only has 3 mandatory markings; Class, Capacity, and d. We have already proposed to change the d to e above.

2.2 Principles of the metrological requirements

The requirements apply to all instruments irrespective of their principles of measurement.

Instruments are classified according to:

- the verification scale interval, representing absolute accuracy; and
- the number of verification scale intervals, representing relative accuracy.

The maximum permissible errors are in the order of magnitude of the verification scale interval. They apply to gross loads and when a tare device is in operation they apply to the net loads. The maximum permissible errors do not apply to calculated net values when a preset tare device is in operation.

A minimum capacity (Min) is specified to indicate that use of the instrument below this value is likely to give rise to considerable relative errors.

In R76, the issue of instrument accuracy is focused on Class, Max and e, parallel to HB44. Absolute accuracy in terms of e and relative accuracy in terms of n. When the load is very small, i.e. less than Min, it might appear that R76 is addressing the large relative errors resulting in 1 e tolerance for some small number of e in load. However, this is not the case. The distinction is that Min applies to use of the instrument and not to testing of the instrument.

In testing under R76 tolerances, rounding errors are eliminated (see 3.5.3.2.). In practice this usually means error weights are used to resolve the instrument errors to at least 0.2 e (NTEP generally uses 0.1 e). In addition, R76 expects that instrument divisions are relatively uniform throughout the series. In order to get a +1 e error at 1 e load and still meet the requirement that the zero division be +/- 0.5 division wide, would require the 1 e divisions be 0 e wide (i.e. be skipped). To visualize in analog, imagine an indicator that starts at zero and jumps immediately to the 2 graduation.

A load of 1 e would indicate 2 e. Likewise a load of 2 e would indicate 3 e and this pattern would repeat until the tolerance breakpoint, a load of 500 e would indicate 501 e. Then the second graduation after the break point would be skipped, i.e. the 502 e graduation. A load of 501 e would indicate 503 e with a +2 e error. All the loads up to 20,000 e would now show a +2 e error. Instruments obviously should not, and DO NOT, operate that way.

If we assume instrument divisions are uniform, as R76 does, then the divisions should be accurate to about the relative % of the accuracy class. For Class II in the first step this is 0.02%. Thus at 20 e load the maximum expected error (after eliminating rounding) should be in the order of 0.004 e, and not the 1 e permitted in the tolerance structure. So, what relative error can R76 be addressing when dealing with Min?

When an instrument is used in commerce, it is the rounding of the indication to ½ scale division that results in large relative errors. Consider a cannabis sale of 1.05 g when the division size is 0.1 g. The instrument must round off to either 1.0 g or 1.1 g. Either one produces an error in the weight of 0.05 g. That's 4.8% relative error in the weight (0.05 g / 1.05 g) with an instrument that's supposed to be accurate to 0.02%. It is this rounding error "in use" that produces the large relative errors addressed in Min in R76 and the minimum load in HB44. This rounding error is a function of d, the displayed scale division, and not e. It is not a tolerance issue.

The confusion comes from the presentation of Min in terms of e in the last column of R76 Table 3. The table in R76 has an additional column for Min not found in HB44. In HB44 it has been relocated to Table 8. Looking closely at Table 8, you will find that the first two columns correspond to the first two columns in Table 3 in HB44. So why does R76 express this column in e instead of d? I suspect they did it because all other values in Table 3 are in e. For instruments where e = d, the issue is moot. Note however, that R76 reveals the ties to d for the Class I and II instruments with an auxiliary indicating device (differentiated least significant digit). In 3.4.3. R76 directs that d replace e in the Min column of Table 3 for instruments with an auxiliary indicating device.

On an instrument where e = 10 d, we can create the same scenario as before but now with a load of 1.005 g. The instrument must now round to either 1.00 g or 1.01 g. The rounding error is now 0.50% of the weight (0.005 / 1.005). That is 10 times smaller at the same 20 e load.

Returning to the four types of instruments from revised S.1.2.2. and applying revised Table 8.:

- | | |
|--|-------------------|
| 1. Graduated without an auxiliary indicating device: | minimum load in d |
| 2. Graduated with an auxiliary indicating device: | minimum load in d |
| 3. Graduated and marked for special use (weight classifier): | minimum load 5 e |
| 4. Ungraduated (equal arm scales): | minimum load in e |

Group 6. Changes to correctly reference to e or d as appropriate.

S.1.1.1. Digital Indicating Elements.

(a) A digital zero indication shall represent a balance condition that is within $\pm \frac{1}{2}$ the value of the verification scale division.

*(b) A digital indicating device shall either automatically maintain a "center-of-zero" condition to $\pm \frac{1}{4}$ verification scale division or less, or have an auxiliary or supplemental "center-of-zero" indicator that defines a zero-balance condition to $\pm \frac{1}{4}$ of a verification scale division or less. A "center-of-zero" indication may operate when zero is indicated for gross and/or net mode(s).
[Nonretroactive as of January 1, 1993]*

*(c) For electronic cash registers (ECRs) and point-of-sale systems (POS systems) the display of measurement units shall be a minimum of 9.5 mm (3/8 inch) in height.
[Nonretroactive as of January 1, 2021]*

(Added 2019)

(Amended 1992, 2008, ~~and~~ 2019, and 20XX)

The changes correctly reference e in this section as this is an issue of ensuring the zero indication is accurate to $\frac{1}{4} e$. Hence it is a tolerance properly expressed in terms of e.

T.N.9. Radio Frequency Interference (RFI) and Other Electromagnetic Interference Susceptibility. – The difference between the weight indication due to the disturbance and the weight indication without the disturbance shall not exceed one verification scale division (~~d~~) (e); or the equipment shall:

- (a) blank the indication; or
- (b) provide an error message; or
- (c) the indication shall be so completely unstable that it cannot be interpreted, or transmitted into memory or to a recording element, as a correct measurement value.

The tolerance in T.N.9. Radio Frequency Interference (RFI) and Other Electromagnetic Interference Susceptibility is to be applied independently of other tolerances. For example, if indications are at allowable basic tolerance error limits when the disturbance occurs, then it is acceptable for the indication to exceed the applicable basic tolerances during the disturbance.

(Amended 1997 and 20XX)

This is a tolerance for reaction to a disturbance and is properly expressed in e.

Group 7. Identify appropriate application of code sections (in order of appearance)

When the paragraph references d it is referring to the actual scale division and the concern is how the instrument operates. When the paragraph references e it is referring to the verification scale division and the concern is in classification of the instrument or in accuracy of the displayed values.

The sections in the table below currently correctly reference e or d as appropriate. The text of each section is not included for brevity. The justification may help explain the general rules above.

| Code Section | Applies to | Justification |
|---------------|------------|---|
| G-S.5.2.2.(c) | d | Rounding is a function of instrument operation not accuracy |
| G-S.5.2.2.(d) | d | Requires “d” to be an indicated zero and all digits to the left of “d” to be zero when $d < 1$. Requires “d” to be an indicated zero and all digits to the right of “d” to be zero when $d > 5$. |
| S.1.2. | d | 1, 2, or 5 refers to d which is rounded. When $e \neq d$ refer to section S.1.2.2. for value of e. |
| S.1.2.1 | d | Refers to rounded values of d. |
| S.1.2.3. | e | This is a classification issue. It ensures accuracy of the piece counts. |
| S.1.7.(b) | e | This is a classification issue addressing maximum indication above capacity. |
| S.2.1.2. | d | They must be in terms of d since stability of zero setting applies to d. |
| S.2.1.3.(all) | d | These limit the window for action of AZT. They must be in terms of d since zero setting applies to d. |
| S.2.3. | d | Tare division must equal smallest increment displayed. |
| T.N.7. | d | Discrimination requires an instrument to discriminate to the displayed scale division (zone of uncertainty). This relates to the rounding of the smallest increment. |
| UR.3.7. | d | Minimum load is correctly expressed in d. (see Group 5 above) |
| UR.3.10. | e | As written, this is clearly e. (See issues for additional study) |

PART 3. Issues Identified as Requiring Additional Study (outside the scope of this workgroup)

A. The workgroup was in consensus that we should expand requirements in S.2.1.2. relating to semi-automatic zero to apply to all scales and not just scales used in direct sale. In first place, suitability is a User Requirement and not a specification. Second, correct operation to set zero should be applicable to all digital instruments as it is in R76.

B. The application of tolerances to net loads has always been assumed, even before the Scales Code adoption in 1984. Comparing T.2. for unmarked scales and T.N.2.1. for marked scales reveals important differences particularly regarding net loads. As written, T.N.2.1. exempts calculated net, but it appears to apply to both semi-automatic tare and preset tare. A comparison to R76 shows that OIML limits applicability of tolerances. Their MPE's do not apply to calculated net values or when preset tare (keyboard or programmed tare) is in operation (section 2.2). It appears net loads have MPE's applied only when the net zero is set in compliance with S.1.1.1.(b) which requires accuracy of zero to ¼ division. This cannot be assured with preset tare or when net is based on two gross values. This has further ramifications to any case where all three (gross, tare and net) values are indicated/recorded for a transaction. OIML requires the gross and net weights be accurate but does not apparently require that the equation gross – tare = net be in mathematical agreement due to rounding issues. Note that in most transactions, the customer only gets one or two of the gross, tare or net values. Rounding issues do not arise for this reason. This may impact a current issue before NCWM dealing with printing tare on POS transaction receipts. Consider a POS transaction where the customer saw 1.02 lb on the weight display and sees 1.00 lb net and 0.03 lb tare. These are all accurate weights (and correct per R76) but the numbers don't add up. The customer will claim they were overcharged by 0.01 lb since $1.02 \text{ lb} - 0.03 \text{ lb} = 0.99 \text{ lb}$.

C. The resolution of errors in testing scales was identified as an issue. The original proposal included a revision requiring resolution of error to at least 0.2 e. R76 specifically declares that errors be resolved to at least 0.2 e to eliminate rounding error. HB44 has no such provision and it might appear that rounding error is included in the tolerance. Instead of tolerance steps of 1, 2, etc., it could be argued that the tolerances are 1.5, 2.5, etc. as the result of direct reading. NTEP uses the R76 approach exclusively in testing, but it has no technical basis in the Code. There are obvious issues involved in using error weights in the field. The challenge is that you either eliminate rounding in determining tolerances or you don't. We have two standards at play at present. In addition, it can be argued that Class IIIIL instruments are already high resolution somewhat similar to Class I and II instrument with $e > d$. Class IIIIL devices have enough resolution to read errors to 0.2 e or 0.1 e of the equivalent Class III instrument without using error weight.

D. The UR.3.10. requirement that transactions from dynamic monorail scales be based on e raises issues. It was discussed since it involves both e and d. The displayed scale divisions equal to e (i.e. 10 d) are not normally rounded. If $e = 10 d$ then the rounding point is not 5 up/4 down, as it is for d, but rather 9.5 up/0.5 down. Does this requirement mean the scale design has to produce a properly rounded value for the transaction that may be different from the display, e.g. 943.7 lb to d of 0.1 lb now must be recorded for the transaction as 944 lb? In addition, in brief discussion, it seemed there were many ways this could be interpreted. The workgroup concluded it would be beneficial to open some discussions with USDA and the manufacturers to explore some of these questions. This also addresses similar issues to the proposal to delete S.1.2.2.2. where questions of using e or d are impacting high precision scales in cannabis and jeweler's sales.